

The right choice for the ultimate yield!

LS ELECTRIC strives to maximize your profits in gratitude for choosing us as your partner.

CANopen Option Module

LSLV-G100 series

User's Manual

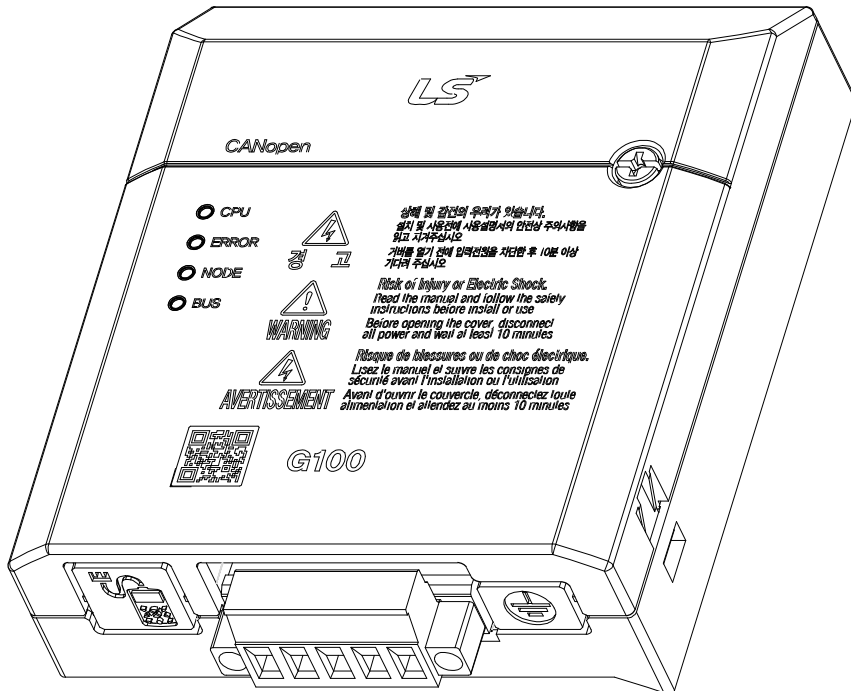

Safety Instructions

- Use this board after read Safety Instruction of this manual carefully before using and follow the instructions exactly.
- Please hand this user manual to end user and trouble shooting manager
- After read this manual, keep it at handy for future reference.
- 사용 전에 '안전상의 주의사항'을 반드시 읽고 정확하게 사용하여 주십시오.
- 본 설명서는 제품을 사용하는 사람이 항상 볼 수 있는 곳에 잘 보관하십시오.

LSELECTRIC

Before using the product

Thank you for using the G100 Series CANopen communication module.

Safety Information

- Always follow safety instructions to prevent accidents and potentially hazardous situations.
- Safety precautions are classified into "WARNING" and "CAUTION," and their meanings are as follows:

Warning

Improper operation may result in serious personal injury or death.

Caution

Improper operation may result in minor personal injury or property damage.

- Symbols used in this document and on the product indicate the following.

 Danger may be present. Read the message and carefully follow the instructions.

 Close attention should be paid because the risk of electric shock may be present.

- Keep the operating instructions handy for quick reference.
- Read the operating instructions carefully to fully understand the functions of the G100 series CANopen communication module and use it properly.

Caution

- Be careful not to damage the CMOS elements on the communication module. Static charge may cause malfunctioning of the product.
- Turn off the inverter before connecting communication cables. Otherwise, the module may be damaged or a communication error may result.
- Correctly install the communication module and ensure that it is firmly connected to the inverter. Otherwise, the module may be damaged or a communication error may result.
- Check the parameter units when configuring the parameter values. Otherwise, a communication error may occur.

Table of Contents

1 Overview	1
1.1 What is CANopen?	1
1.2 What are the Benefits of Using the CANopen Communication Module?	1
1.3 Package Content	1
2 CANopen Communication Module	2
2.1 Technical Specifications	2
2.2 CANopen Communication Module Layout	3
2.3 Installing the CANopen Communication Module	4
2.4 Grounding the CANopen Communication Module	5
2.5 CANopen Connection Terminal Layout	6
2.6 Hardware Installation	7
2.7 Maximum Communication Range by Baud Rate.....	10
3 Device Status and LED indicators	11
3.1 LED Indicators	11
3.2 Device Status by Indicator Signals	11
4 CANopen Data Communication Protocol	14
4.1 CANopen Communication Protocol	14
4.1.1 CAN-ID.....	14
4.1.2 SDO Communication	15
4.1.3 PDO Communication	15
4.2 Network Management (NMT) State Machine	17
4.2.1 NMT State "Initialization"	19
4.2.2 NMT State "Pre-operational"	19
4.2.3 NMT State "Operational"	19
4.2.4 NMT State "Stopped".....	20
4.2.5 Frame Availability by the NMT Status	20
4.3 Error Control Protocols	20
4.3.1 Node/Life Guarding Protocol	20
4.3.2 Heartbeat Protocol.....	21
4.4 CANopen EDS File	21
5 Detailed Specification of Communication Profile Specific Objects	22
5.1 Device Type	22
5.2 Error Register.....	22

5.3	Predefined Error Field.....	24
5.4	COB-ID SYNC Message.....	25
5.5	Manufacturer Device Name.....	25
5.6	Manufacturer Hardware Version.....	26
5.7	Manufacturer Software Version	26
5.8	Guard Time	26
5.9	Life Time Factor	27
5.10	COB-ID EMCY	27
5.11	Producer Heartbeat Time	27
6	Profile.....	28
6.1	CiA 402 Drive and Motion Control Device Profile.....	28
6.1.1	Finite State Automation	28
6.1.2	CiA 402 SDO	30
6.1.3	SDO for G100 Inverter Operation	36
6.2	PDO	38
6.2.1	RPDO.....	38
6.2.2	RPDO MAPPING	39
6.2.3	TPDO	40
6.2.4	TPDO MAPPING	41
7	Inverter Parameters	42
7.1	List of Related Parameters	42
7.2	Basic Field Bus Parameters	44
7.2.1	Set Command Source for the Inverter–Cmd Source (drv)	44
7.2.2	Set Frequency Command Source for the Inverter–Freq Ref Src (Frq)	44
7.2.3	Set Station ID–Fbus ID (CM-07).....	44
7.2.4	View Indicator LED States–Fbus Led (CM-9).....	45
7.2.5	Run Comm Update (CM-94).....	45
7.2.6	Set the Network Speed (Baud Rate)–Opt Parameter1 (CM-10)	46
7.2.7	Set Profile–Opt Parameter2 (CM-11)	46
7.2.8	View Communication Module Version–Fbus SW ver (CM-06)	47
7.3	Parameter Setting for Periodic Communication	47
7.3.1	Set LS Profile Output Address–Para Status 1–4 (CM-31–34).....	47
7.3.2	Set LS Profile Input Address–Para Status 1–4 (CM-51–54)	48
7.4	Parameter Setting for Lost Command	48
7.4.1	Lost Command Operation–Lost Cmd Mode (Pr-12).....	48
7.4.2	Command Loss Decision Time–Lost Cmd Time (Pr-13).....	49

1 Overview

1.1 What is CANopen?

CANopen is a type of Fieldbus network utilizing CAN (Controller Area Network) specified by the CiA (CAN in Automation) Association.

Currently, CANopen is utilized in the fields such as machine control, medical equipment, automotive electronics, and building automation.

1.2 What are the Benefits of Using the CANopen Communication Module?

Using the network features, controlling and monitoring of the inverter can be performed via a PLC sequence program or a master device.

Because multiple inverters can be operated with one communication cable, this reduces the total installation cost. In addition, installation time is reduced and easy maintenance is made available because installation and routing of cables has become simpler.

Factory automation can also be easily implemented by linking various auxiliary devices with a PLC and by utilizing other control systems, such as a PC, for controlling the inverter.

1.3 Package Content

The product package includes the following components.

- CANopen Communication Module (CCAN-G100): 1 ea
- CANopen User Manual: 1 ea

2 CANopen Communication Module

2.1 Technical Specifications

Items		Description
Power Supply	CANopen Power supply for CANopen communication module	Supplied from inverter.
Network Topology		Bus Topology
Communication Baud Rate		20 kbps, 50 kbps, 100 kbps, 125 kbps, 250 kbps, 500 kbps, 800 kbps, 1 Mbps
Max. Number of Nodes		64 Nodes (including the master node) When 1 master device is connected to the network, the maximum number of inverter nodes is 63 (64-1).
Device Type		AC Drive
Supported Communication Types		Process Data Object (PDO), Service Data Object (SDO), Synchronization (Sync), Network Management (NMT)
Terminal Resistor		120 ohm 1/4W (Built-in)
Available PDO		PDO1 (CiA 402 Drive and Motion Control device profile) PDO3 (LS Profile)
Vendor ID		0x7D
PDO Mapping		N/A
Group Messaging		N/A
LSS Supported		N/A

2.2 CANopen Communication Module Layout

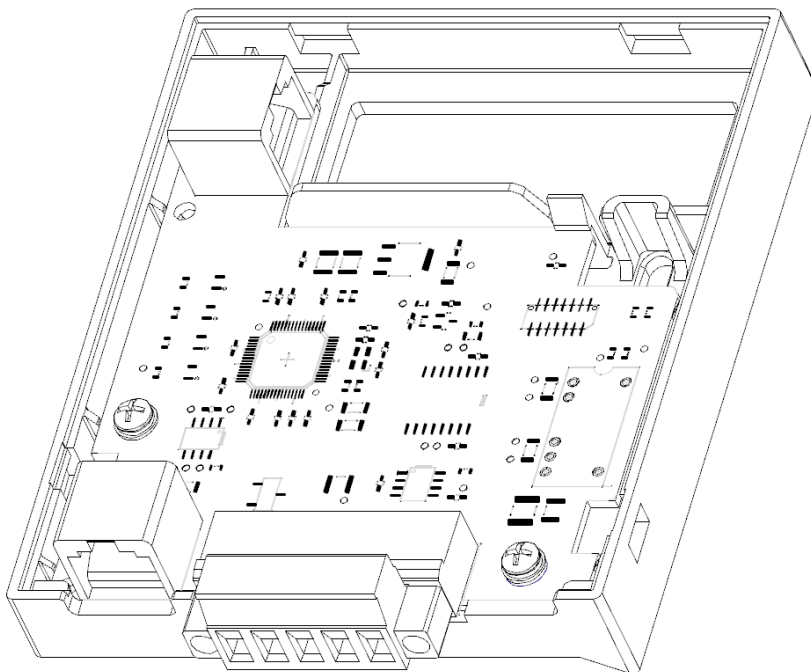
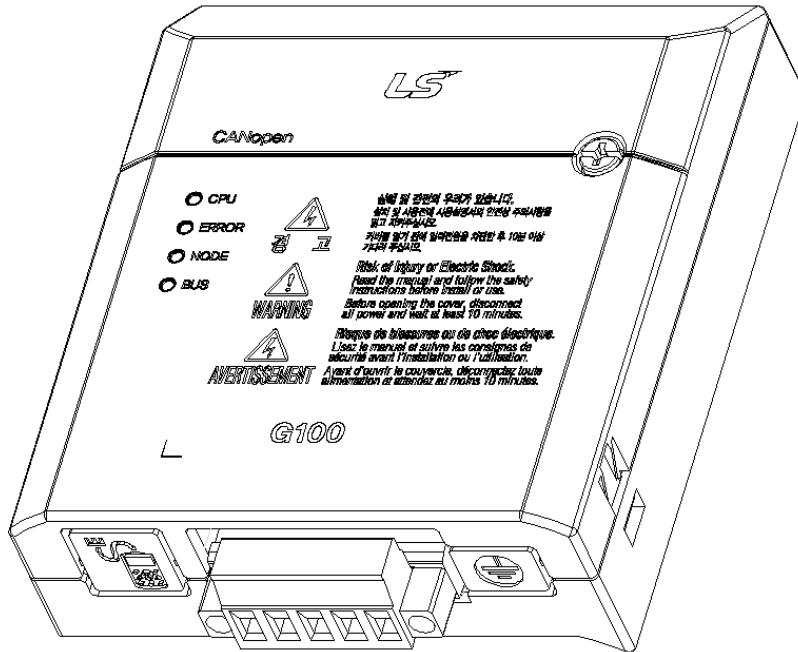

2.3 Installing the CANopen Communication Module

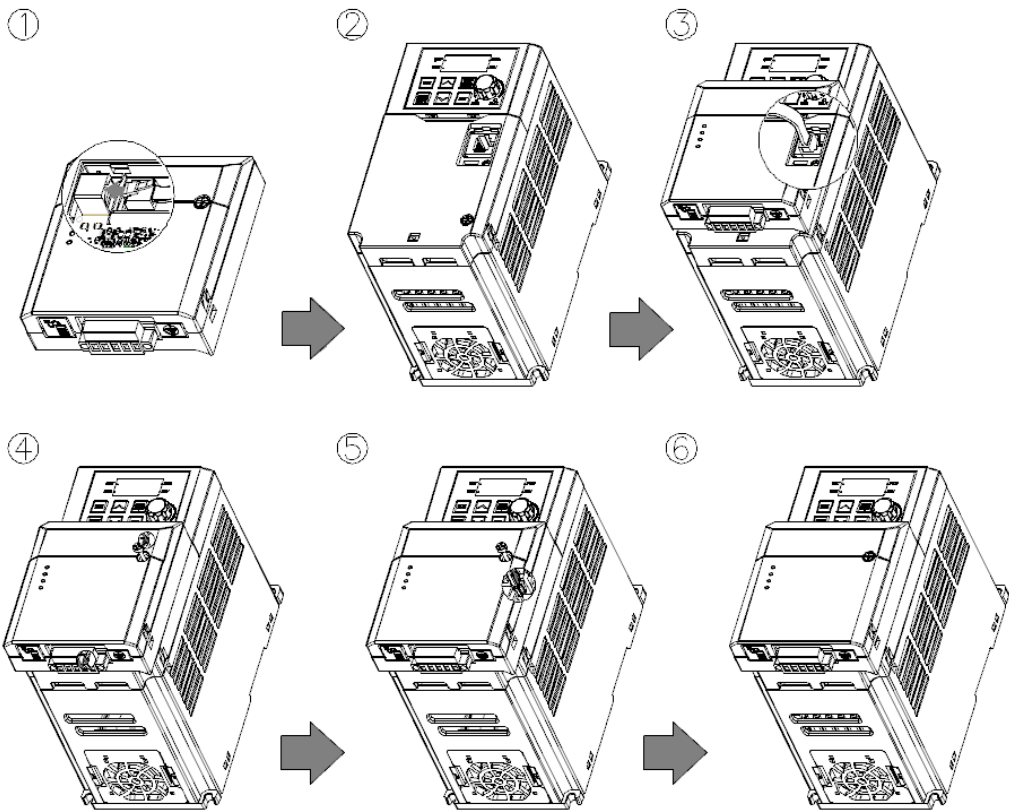

- 1 Get the G100 CANopen communication module ready for installation. (A dedicated RJ-45 cable is attached to the module.)
- 2 Remove the front cover from the G100 inverter.
- 3 Connect the communication module to the G100 inverter using the RJ-45 network cable.
- 4 Hook up the communication module to the installation slot on the inverter.
- 5 Install the fixing bolt provided with the communication module using an appropriate tool.
- 6 The CANopen communication module has been installed on the G100 Inverter.

Warning

- Do not install or remove the communication module to or from the G100 inverter while the inverter is turned on.
- Install or remove the communication module to or from the G100 inverter only after the electric charge of the capacitor inside the inverter has been completely discharged.
- Ensure that the cable connection between the module and the inverter (dedicated RJ-45 cable) is not loose or disconnected.

2.4 Grounding the CANopen Communication Module

Follow the instructions below to ground the CANopen communication cable (shielded cable). The ground cable is not included in the product package.

①

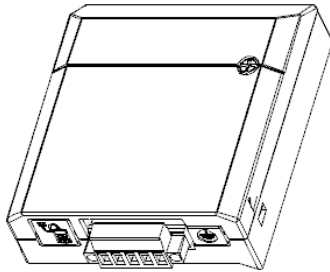

②

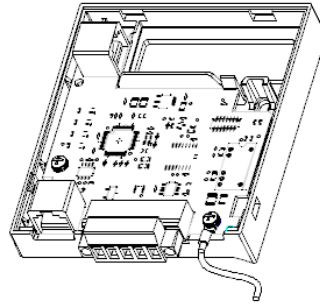

③

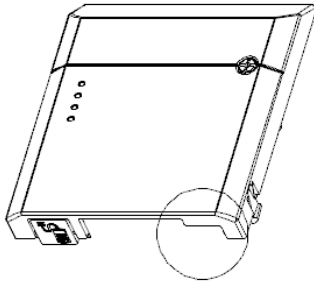

④

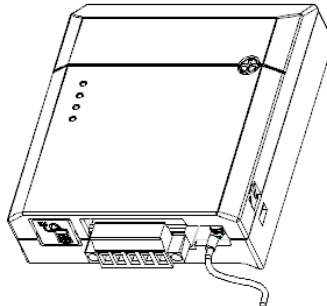

- 1 Remove the front cover from the communication module.
- 2 Fix the ground cable to the communication module using the bottom screw on the circuit board.
- 3 Remove the knockout panel with the grounding symbol from the front cover.
- 4 Install the front cover to the communication module.

2.5 CANopen Connection Terminal Layout

CANopen 통신 케이블(차폐 케이블)의 케이블 접지를 사용할 경우에 아래와 같이 연결합니다. 접지 와이어는 별도로 제공하지 않습니다.

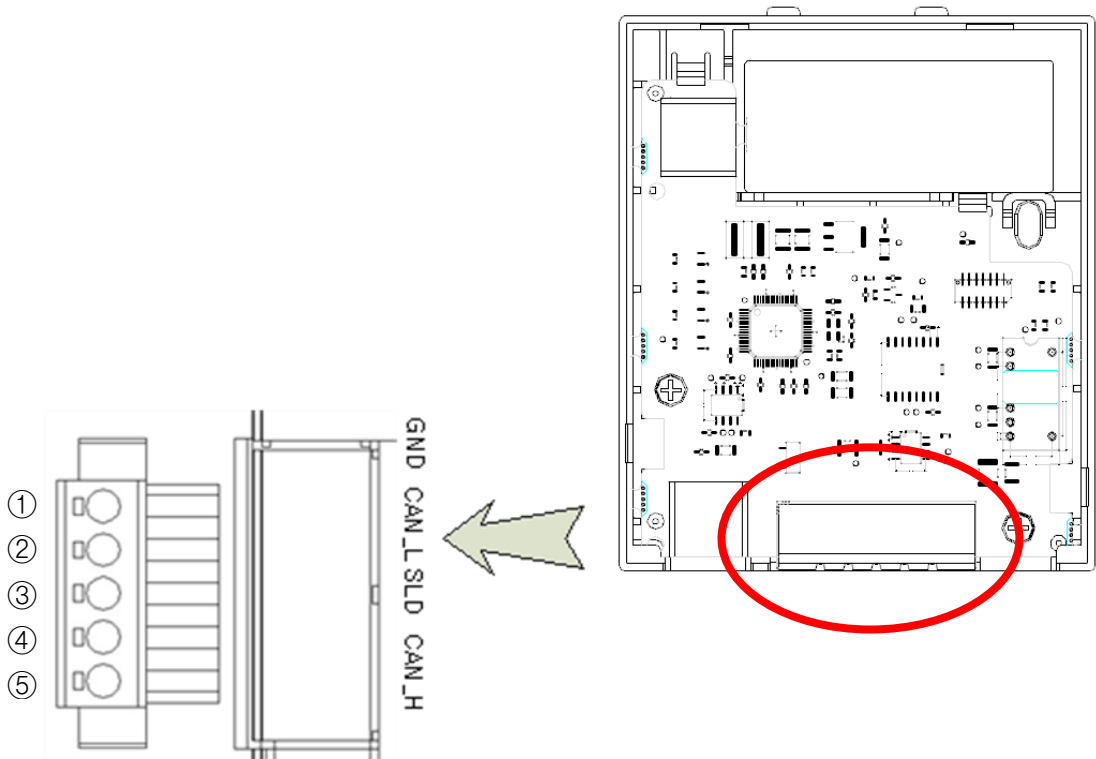

No	Signal	Description
1	GND	CAN Ground
2	CAN_L	CAN_L Bus Line (Dominant Low)
3	SLD	CAN Shield
4	CAN_H	CAN_H Bus Line (Dominant High)
5	-	Reserved

※ The PHOENIX STLZ950/5F-5.08-H-GREEN connector is used for cable connections. (5 pin connector)

2.6 Hardware Installation

Warning

Turn off the inverter before configuring the communication network.

Both the inverter and the communication module will be damaged if the communication module is installed or removed while the inverter is turned on. Install or remove the communication module after the capacitor inside the inverter is completely discharged.

To reduce signal noise, the CANopen communication modules at both ends of the network must be terminated. You can turn on the terminal resistor setting switch on the CANopen communication module to enable termination. A resistance of $120\ \Omega$ 1/4W is applied between CAN_L and CAN_H terminals after the terminal resistance is switched on.

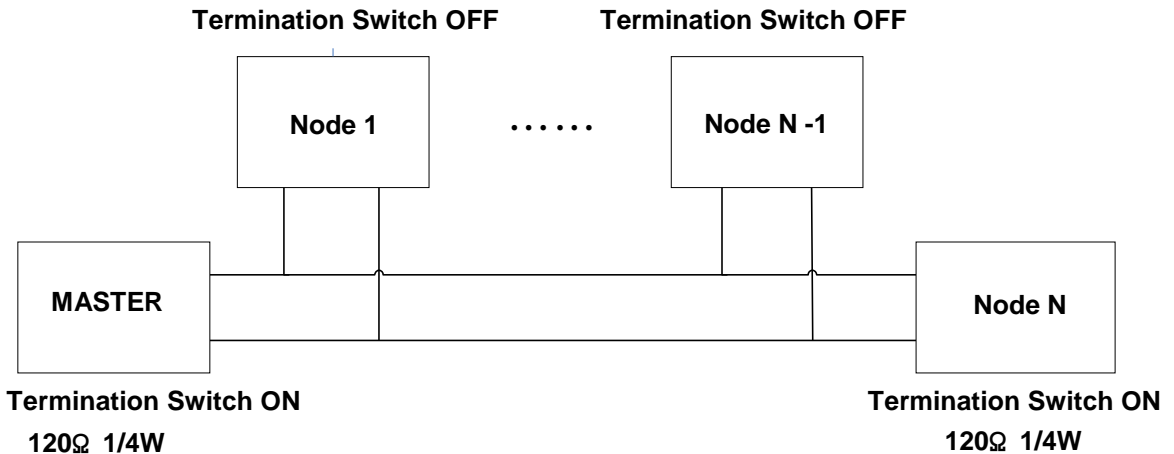

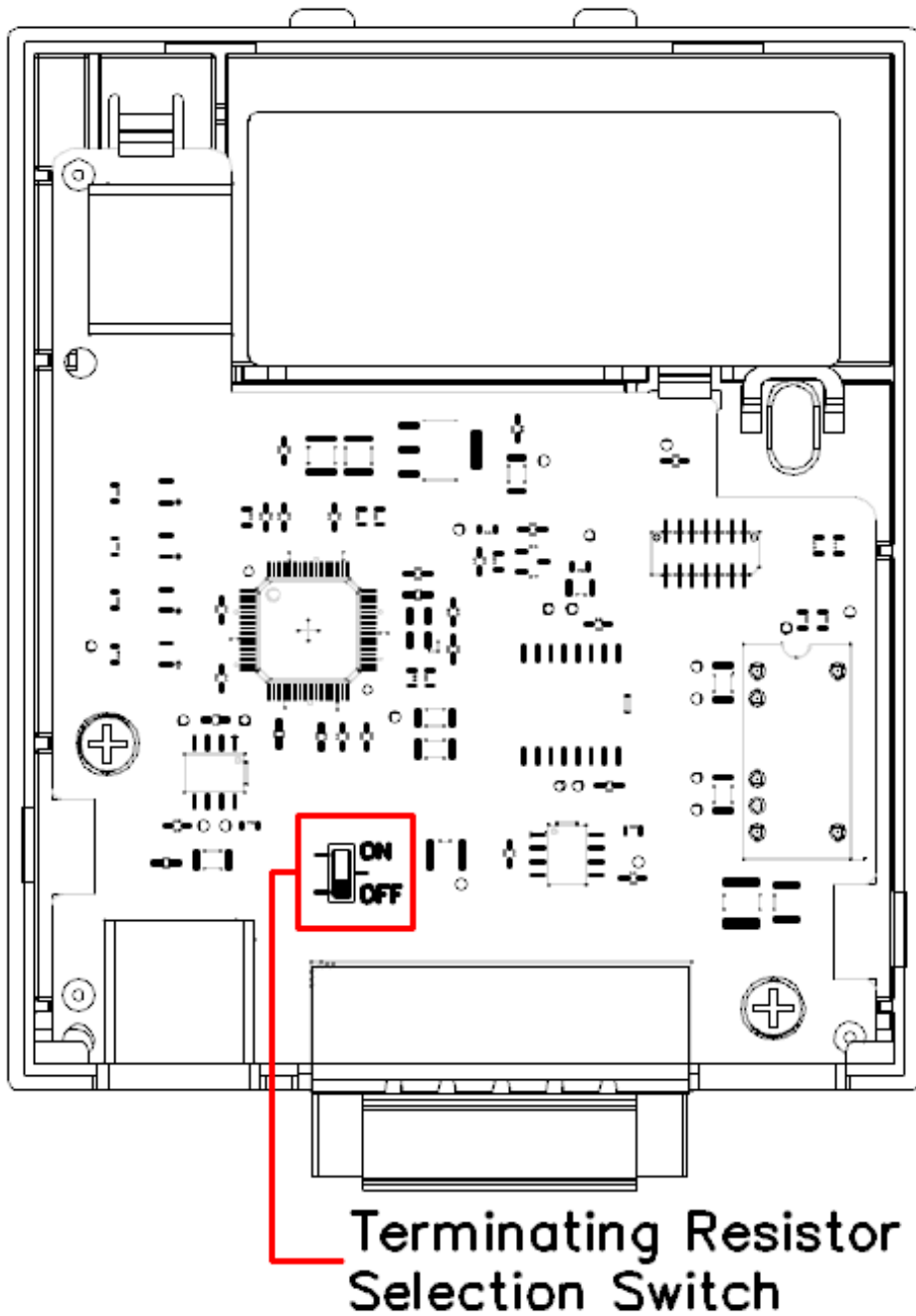

When the termination resistor selection switch is set to the bottom (Off) → Termination resistor is disabled.

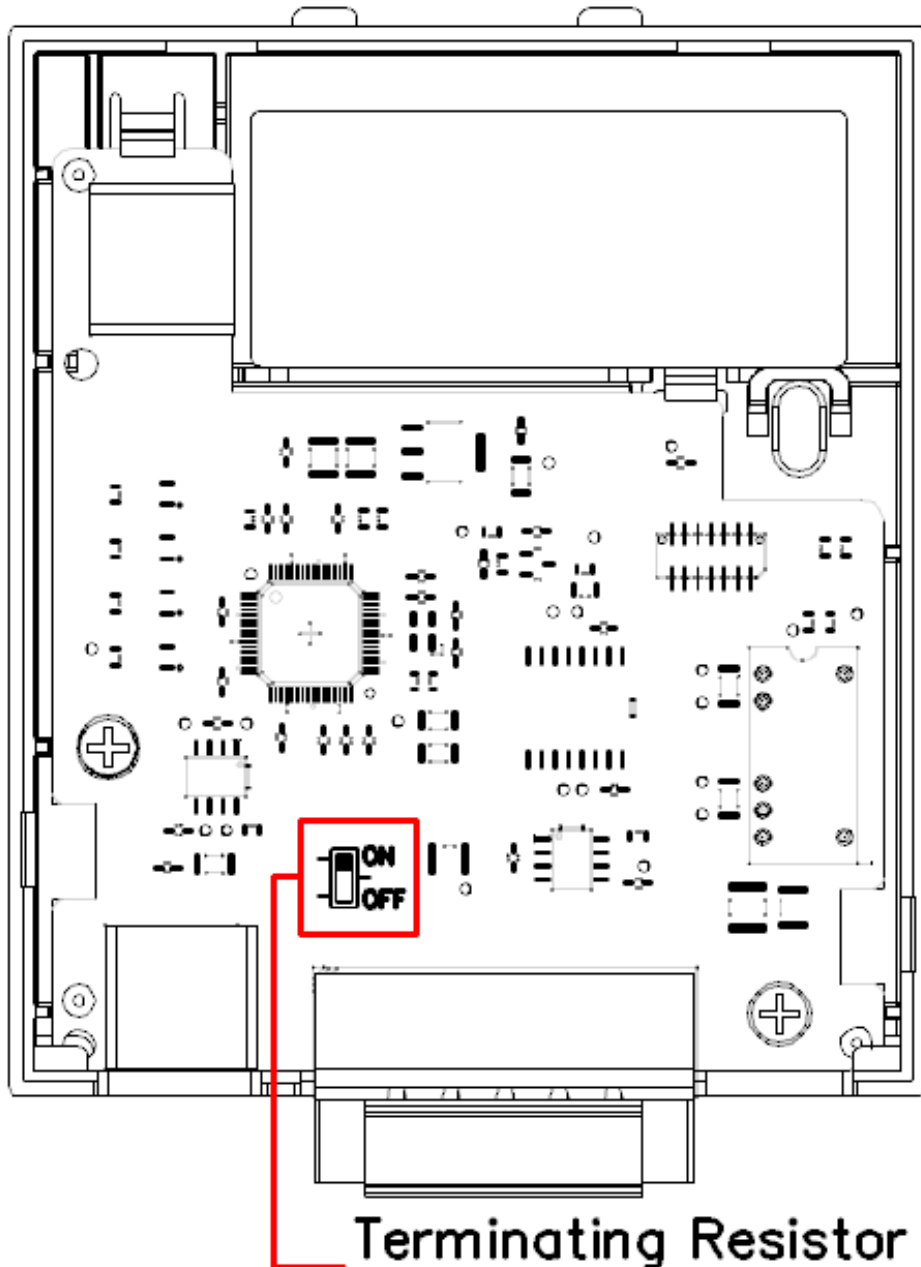

Terminating Resistor Selection Switch

When the termination resistor selection switch is set to the top (On) → Termination resistor is enabled.

2.7 Maximum Communication Range by Baud Rate

In a network system, the total length of the network cable is determined by the baud rate. The communication quality cannot be guaranteed if the network cable length exceeds the following cable length limits.

The table below presents the guaranteed communication distance when 18 AWG DeviceNet cable is in use (thick cable).

Baud Rate	Bus Length	Remark
1 Mbps	25 m	
800 kbps	50m	
500 kbps	100m	
250 kbps	250m	
125 kbps	500m	
100 kbps	700m	
50 kbps	1,000m	
20 kbps	2,500m	

Note) The G100 CANopen communication module does not support 10 kbps network speed.

Recommended cable: AC parameters: 120-Ω impedance
 5-ns/m specific line delay
18AWG Cable(Thick Cable)

3 Device Status and LED indicators

3.1 LED Indicators

The CANopen communication module has 4 LED indicators.

Indicator	Color	Description
CPU	Green	Flashes at 1 second intervals when the communication module is powered on and the CPU is operating normally (turns on for 500 ms and turns off for 500 ms).
ERR	Red	Turns on if the communication module parameters have been set up incorrectly, or the internal CAN communication between the inverter and the communication module failed.
NODE	Green	Turns on according to the current NMT (Network Management) status.
BUS	Green	Turns on if a communication speed or profile setting different from the master device setting is used for the communication module.

3.2 Device Status by Indicator Signals

Indicator	LED Signal	Device Status	Possible Cause	Resolution
CPU	Kept Off	No Power	Power supply (5 V) to the CANopen communication module failed.	Check if the inverter has been turned on. Check power supply to the CANopen communication module.
	Flashes at 1 sec intervals	Powered On	5 V power is supplied.	Normal status
ERR	Kept Off	No Error	Module settings are normal	Normal status
	Flashes synchronously with the CPU LED	Communication error between the inverter and the communication module	Data communication between the inverter and the communication module failed.	Turn off the inverter, reinstall the communication module and then turn on the inverter again.

Device Status and LED indicators

Indicator	LED Signal	Device Status	Possible Cause	Resolution
	Flashes asynchronously with the CPU LED	MAC ID Setting Error	"CM-7 (FBus ID)" has been set to "0."	Set the FBus ID to a number between 1–127 and set "CM-94 (COMM Update)" to "1 (Yes)."
	Flashes at twice the interval of the CPU LED.	Opt Parameter Setting	The CANopen communication module parameter settings differ from the parameter settings configured by the keypad.	Set "CM-94 (COMM Update)" to "1 (Yes)" apply the keypad settings to the communication module. To maintain the parameter settings stored on the communication module, set the parameter values again using the original setting values, or turn off the inverter and turn it on again. The parameter settings on the CANopen communication module are maintained while the ERR LED is flashing.
NODE	Kept Off	CANopen Not Initialized	If the NODE LED has not yet turned on after the CANopen communication module was powered on, this means that the module is not ready for CANopen communication because it has not been initialized yet.	If the LED does not turn on for a long time, set "CM-94 (COMM Update)" to "1(Yes)."
	Kept OFF	CANopen Stopped	If the NODE LED has been lit at least once, the CANopen master device has issued a stop command.	Normal status

Indicator	LED Signal	Device Status	Possible Cause	Resolution
	Flashes synchronously with the CPU LED	CANopen Pre-operational	CANopen communication with the master device is available, but the connection with the master device has not been made yet.	Normal status
	Kept On	CANopen Operational	Successfully connected to the master device and the CANopen communication is operated normally.	Normal status
BUS	Kept OFF	Bus Off	The CANopen communication module has been disconnected from the network due to a network problem.	Check the network cable connection. Ensure that the terminal screws are properly tightened. Turn off the power, then turn it back on.
	Flashes synchronously with the CPU LED	CANopen Profile Setting Error	The profile set on the CANopen master device differs from the profile setting on the communication module.	Check that the PDO settings and ensure that the same settings are used for the master device and the communication module.
	Flashes at twice the interval of the CPU LED.	PDO Communication Not Connected	The CANopen network speeds were set differently.	Ensure that the same network speed (baud rate) is set for the master device and the communication module.
			Connection with the master device has not been made for communication.	Ensure that the master device has started communication.
			Network cable has not been connected yet.	Check that network cable has been connected correctly.
Kept On	No CANopen Network Bus Errors	The CANopen network has no problems.	Normal status	

4 CANopen Data Communication Protocol

4.1 CANopen Communication Protocol

4.1.1 CAN-ID

The G100 CANopen communication module supports only the CAN2.0A (Standard) protocol.

The CAN2.0A protocol uses 11Bit IDs.

The figure below shows the configuration of the ID.

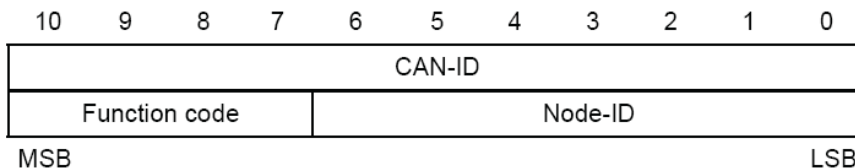

The table below presents the Broadcast Function codes.

COB	Function code	Resulting CAN-IDs
NMT	0000b	0 (0x000)
SYNC	0001b	128 (0x080)
TIME	0010b	256 (0x100)

Note) Communication Object (COB) is a part of the CAN Message Frame which shows the unit of transmission on a CAN Network.

The table below presents the function codes for a peer-to-peer connection.

COB	Function code	Resulting CAN-IDs
EMCY	0001b	129(0x81)~255(0xFF)
PDO1 (tx)	0011b	385(0x181)~511(0x1FF)
PDO1 (rx)	0100b	513(0x201)~639(0x27F)
PDO3 (tx)	0111b	897(0x381)~1023(0x3FF)
PDO3 (rx)	1000b	1025(0x401)~1151(0x47F)
SDO (tx)	1011b	1409(0x581)~1535(0x5FF)
SDO (rx)	1100b	1537(0x601)~1663(0x67F)

Data is transmitted through a variety of Communication Objects (COB) in the CANopen data frame.

Process Data Objects (PDO) are used to transmit the data requiring real-time transmission (Real-time data), while Service Data Objects (SDO) are used to transmit the data that does not require real-time transmission.

4.1.2 SDO Communication

SDO communication is used for Peer-to-peer data communication between two CANopen devices, which does not require real-time transmission (Ex: setting the parameter values).

SDO communication accesses objects with the combination of the object index and sub-index, and allows for reading and writing of all the objects in the object directory.

4.1.3 PDO Communication

PDO communication is used to send and receive data requiring real-time transmission (real-time data). Data is transmitted without overhead or confirmation of the protocol (index, sub-index, and data). Such features make PDO communication useful for IO communication.

PDO communication can be divided into two types depending on the transmission direction; RPDO (Receive PDO) for receipt of data from the master device and TPDO (Transmit PDO) for transmission of data to communicate with the master device.

The G100 CANopen communication module is available for PDO communication for frequency conversion that is supported by the CiA 402 Drive and Motion Control device profile (only PDO1 and PDO3 communications are supported).

PDO1 and PDO3 communications cannot be utilized at the same time.

► PDO Transmission Modes

- **Synchronous transmission**
PDOs are transmitted according to the SYNC frame. The interval between the two SYNC objects becomes the communication interval.
- **Asynchronous (Event-driven transmission) transmission**
PDOs are transmitted according to specific events

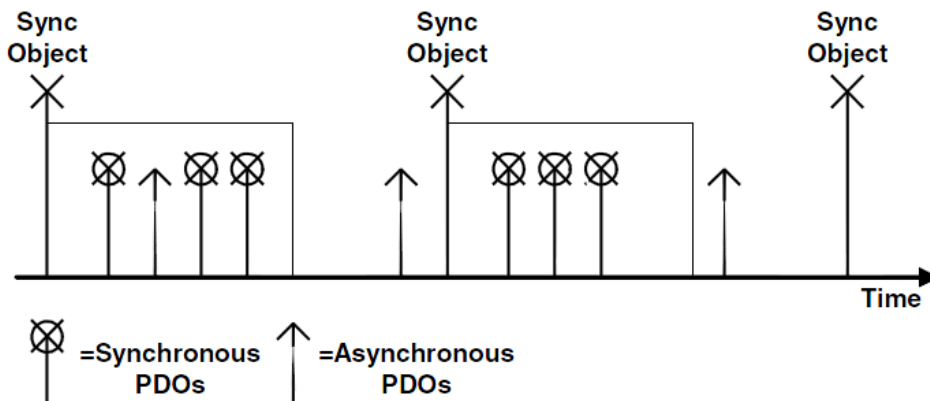

Synchronous and Asynchronous Transmission

► Triggering modes

There are three triggering modes to choose between when to transmitting TPDOs.

- **Event- and timer-driven**
The PDO frame is transmitted when the preset event time elapses.
- **Remotely requested**
The TPDO frame is transmitted when the remote transfer request (RTR) frame requesting a PDO transmission is received.
- **Synchronously triggered**
The TPDO frame is transmitted when the preset number of SYNC frames are received.

4.2 Network Management (NMT) State Machine

This command is used by the master device to control the slave devices in the network.

The NMT slave devices perform the NMT slave state machine.

The devices can be configured only in pre-operational states.

The figure below presents the NMT state diagram of a CANopen device.

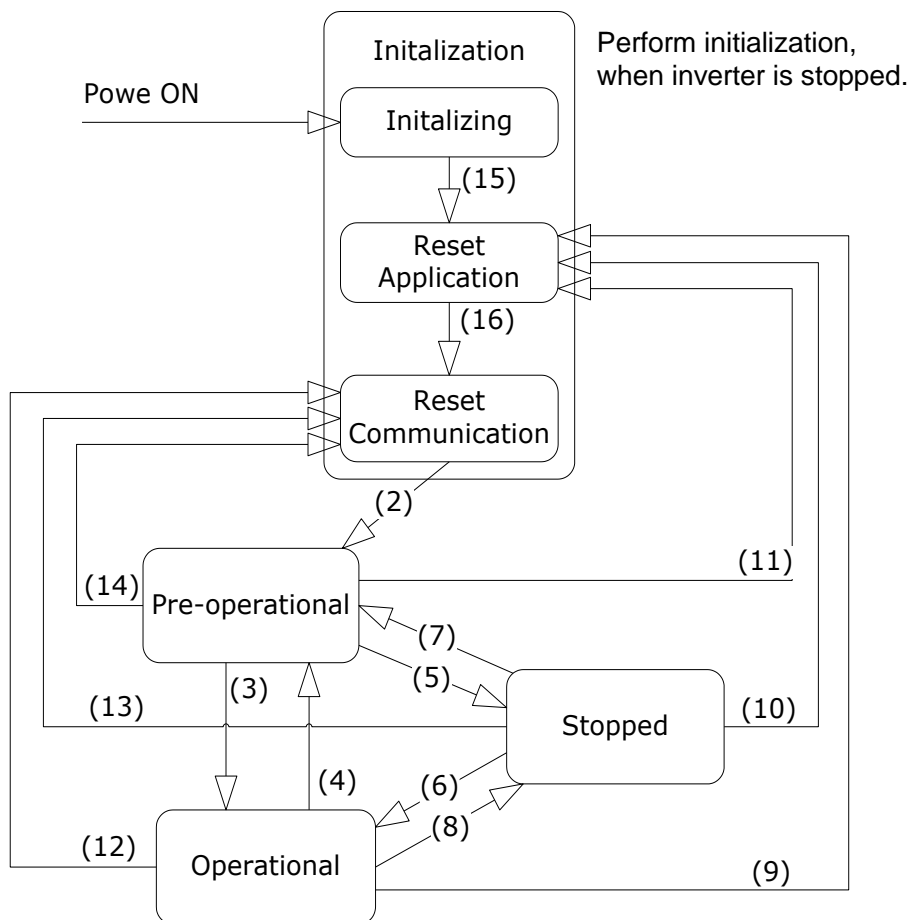

NMT State Transformation	Transformation Condition
(1)	The NMT state is automatically initialized when the powered is supplied.
(2)	After the NMT state initialization, an automatic transition takes place in a "Pre-operational" state.
(3)	The device enters an "Operational" state when a Start_Remote_Node command is received from the NMT master device.
(4), (7)	The device enters a "Pre-operational" state when a Enter_Pre-operational_State command is received from the NMT master device.
(5), (8)	The device enters a "Stopped" state when a Stop_Remote_Node command is received from the NMT master device.
(9), (10),(11)	The device enters a "Reset Application" state when a Reset_Node command is received from the NMT master device.
(12), (13),(14)	The device enters a "Reset Communication" state when a Reset_Communication command is received from the NMT master device.
(15)	After the NMT Sub-state Initialization is complete, the device enters a "NMT Sub-state Reset Application" state.
(16)	After the NMT Sub-state Reset is complete, the device enters a "NMT Sub-state Reset Communication" state.

Note)

NMT Command	Name
001	Start_Remote_Node
002	Stop_Remote_Node
128	Enter_Pre-operational State
129	Reset_Node
130	Reset_Communication

4.2.1 NMT State "Initialization"

Once power is supplied to a CANopen device or a Reset command is executed, the device automatically enters an "Initialization" state. When the initialization is complete, it enters a "Pre-operational" state.

The "Initialization" state can be divided into 3 detailed modes.

Sub-State	Description
Initializing	The initial status of the communication module which is the initialization stage after a power-on or a H/W reset.
Reset Application	Status of the device when the NMT requests a node reset. The initialization is performed according to the profile.
Reset Communication	Status of the device when the NMT requests a communication reset. The device notify the master device of its boot-up via the NMT frame and automatically enters a "Pre-operational" state.

4.2.2 NMT State "Pre-operational"

Prior to PDO communication, the master device transmits the PDO information to the slave device or reads the required data from the slave device via SDO communication. This is the step for preparing PDO communication via SDO communication before starting PDO communication.

In this state, when a Start_Remote_Node command is received from the NMT master device, the device enters an "Operational" state.

4.2.3 NMT State "Operational"

Once the device enters an "Operational" state, all communication objects become "Active," and SDO communication, Synchronization, Error Control, and Emcy Message, as well as PDO communication become available.

In this state, when a Stop_Remote_Node command is received from the NMT master device, the device enters a "Stopped" state.

4.2.4 NMT State "Stopped"

When the device enters a "Stopped" state, all communications other than the NMT and Heart for Error Control communications are stopped.

In this state, when an Enter_Pre-operational_State command is received from the NMT master device, the device enters a "Pre-operational" state.

4.2.5 Frame Availability by the NMT Status

	Pre-operational	Operational	Stopped
PDO	X	O	X
SDO	O	O	X
SYNC	O	O	X
TIME	O	O	X
EMCY	O	O	X
Node control and error control	O	O	O

4.3 Error Control Protocols

An error control protocol refers to a protocol that verifies the CANopen devices in the network for proper operation.

There are two types of error control protocols; Node/Life Guarding Protocol and Heartbeat Protocol.

4.3.1 Node/Life Guarding Protocol

A Node/Life Guarding protocol is used to monitor the CANopen devices in the network to ensure that they operate properly.

The master device transmits an RTR frame to NMT slave devices according to a transmission cycle (a preset Node Guard Time). When a slave device receives the RTR frame, it responds by adding its own NMT state to the RTR frame.

NMT status	Name
4	Prepared
5	Operational
127	Pre-operational

If the master device fails to send the RTR frame or if the slave device fails to respond within the Node Life Time, a Guard Error occurs. If this happens, the G100 CANopen communication module enters a "Pre-operational" state.

4.3.2 Heartbeat Protocol

When the control protocol is set to "Heartbeat," the device sends its own MNT State information at the time intervals set in the Heartbeat Producer device. If the Heartbeat Producer device fails to send Heartbeat signal at the time intervals, a Heartbeat Event occurs in the consumer device.

If the Heartbeat protocol is in use, the G100 CANopen communication module operates as a Heartbeat Producer and informs the consumer device of its current NMT state at the preset intervals.

4.4 CANopen EDS File

The CANopen EDS file is a test file used to control the parameters of the G100 inverter with a Master program such as CANopen Manager.

You can download the EDS file from the LS ELECTRIC homepage (<https://www.lselectric.co.kr>).

After downloading the file, copy it to EDS file folder of the Master Configuration program.

5 Detailed Specification of Communication Profile Specific Objects

5.1 Device Type

The following SDO indicates the device type of the communication module.

Index	0x1000
Data type	UNSIGNED32
Sub-index	0x00
Access	RO (Read-only)
Data	0x00010192 Consisting of two words; the upper word indicates the Frequency Converter (0x01) and the lower word indicate the Drive Profile DSP402 (0x0192).

5.2 Error Register

Error registers provide error-related information for the communication module.

Index	0x1001	
Data type	UNSIGNED8	
Sub-index	0x00	
Access	RO	
Data	Bit	Information
	0	Generic error
	1	Current-related trip (current error)
	2	Voltage-related trip (voltage error)
	3	Temperature-related trip (temperature error)
	4	Reserved
	5	Reserved
	6	Reserved
7	Manufacturer-specific	

Detailed Specification of Communication Profile Specific Objects

Note) The table below presents the inverter trips related to Error Register Data

Error Register Data	Inverter Trip
Generic trip Generic error	HW Diag Fuse Open External Trip BX
Current-related trip Current error	Inverter Overload Trip Over Current1 Ground Trip Over Current2
Voltage-related trip Voltage error	In Phase Open Over Voltage Low Voltage
Temperature-related trip (temperature error)	NTC Open Over Heat
Manufacturer-specific	Ethermal Trip Out Phase Open Over Load Under Load Thermal Trip Pre PID Fail Lost Command

5.3 Predefined Error Field

The table below presents the information about the current emergency states.

Index		0x1003		
Data type	UNSIGNED32			
Object code	Object code			
Sub-index	0x00			
Data type	UNSIGNED8			
Description	Number of the errors			
Access	RW (Read/ Write)			
Data	Read	Number of the current emergency errors		
	Write	Set to "0" to reset all the emergency errors		
Sub-index	0x01			
Data type	UNSIGNED32			
Description	Information of the most recent emergency error			
Access	RO (Read-only)			
Data	Value	Description	Value	Description
	0x0000	None	0x8402	OverSpeed
	0x1000	UNDEFINED	0x8200	Protocol Error
	0x2220	Inverter OLT	0x8210	PDO not processed due to length error
	0x2310	OverCurrent1	0x8220	PDO length exceeded
	0x2330	Ground Trip	0x9001	External Trip
	0x2340	OverCurrent2	0x9002	BX
	0x3130	In Phase Open	0x9003	Safety A Trip
	0x3210	Over Voltage	0x9004	Safety B Trip
	0x3220	Low Voltage	0xFF02	Ethermal
	0x4000	NTC Open	0xFF03	Out Phase Open
	0x4310	Over Heat	0xFF04	Over Load
	0x5000	HWDiag	0xFF05	Under Load
	0x5450	Fuse Open	0xFF06	Thermal Trip
	0x7120	No Motor Trip	0xFF07	Pre PID Fail
	0x8401	Speed Dev Trip	0xFF0A	Lost Command

5.4 COB-ID SYNC Message

An SDO that reads and writes the information about the CAN ID of the device (master device) that sends SYNC Messages.

SYNC Messages control the action of PDOs whose transmission type is "Synchronous."

The bit format is as follows;

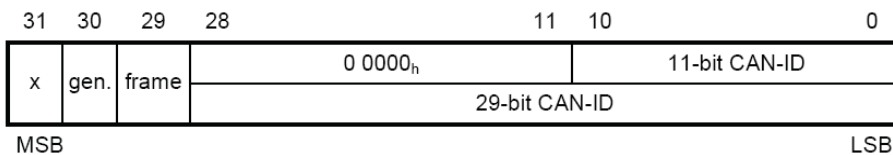

The G100 CANopen communication only receives SYNC and does not generate it. Also, they support only standard IDs. Therefore, both the "gen" and "frame" section must contain "0."

Index	0x1005	
Data type	UNSIGNED32	
Sub-index	0x00	
Access	RW	
Data	Read	COB-ID of the current SYNC setting
	Write	Set up the COB-ID of SYNC

5.5 Manufacturer Device Name

Name information of the CANopen communication module.

Index	0x1008	
Data type	VISIBLE_STRING (Text string)	
Sub-index	0x00	
Access	CONST (Read only data. Unchangeable)	
Data	G100 CANopen	

5.6 Manufacturer Hardware Version

Version data of the CANopen communication module hardware.

Index	0x1009
Data type	VISIBLE_STRING (Text string)
Sub-index	0x00
Access	CONST (Read only data. Unchangeable)
Data	CANopen 1.00 (May vary depending on the actual version of the hardware)

5.7 Manufacturer Software Version

Version data of the CANopen communication module software.

Index	0x100A
Data type	VISIBLE_STRING (Text string)
Sub-index	0x00
Access	CONST (Read only data. Unchangeable)
Data	Version 1.00 (May vary depending on the actual version of the software)

5.8 Guard Time

This SDO sets the Guard Time when using the Node Guarding protocol as the Error Control protocol.

Index	0x100C
Data type	UNSIGNED16
Sub-index	0x00
Access	RW
Data	Guard Time, unit: msec

5.9 Life Time Factor

This SDO sets the Life Time Factor when using the Node Guarding protocol as the Error Control protocol.

Index	0x100D
Data type	UNSIGNED8
Sub-index	0x00
Access	RW
Data	This factor is used to calculate the Node Life Time. It is set to "0" when the Node Guarding protocol is not used.

5.10 COB-ID EMCY

This SDO sets the CAN-ID of the Emergency frame. This SDO is read-only, and cannot be modified for the G100 CANopen communication module.

Index	0x1014
Data type	UNSIGNED32
Sub-index	0x00
Access	RW
Data	\$NODEID+0x80(\$Node ID is the FBus ID currently set in the communication module.)

5.11 Producer Heartbeat Time

This SDO indicates the interval of the Heartbeat transmission.

Index	0x1017
Data type	UNSIGNED16
Sub-index	0x00
Access	RW
Data	Set time in msec units.

6 Profile

6.1 CiA 402 Drive and Motion Control Device Profile

Only Velocity Mode is supported for the G100 CANopen communication module.

6.1.1 Finite State Automation

The following figure presents the state of the communication module when the CiA 402 Drive and Motion Control device profile is in use.

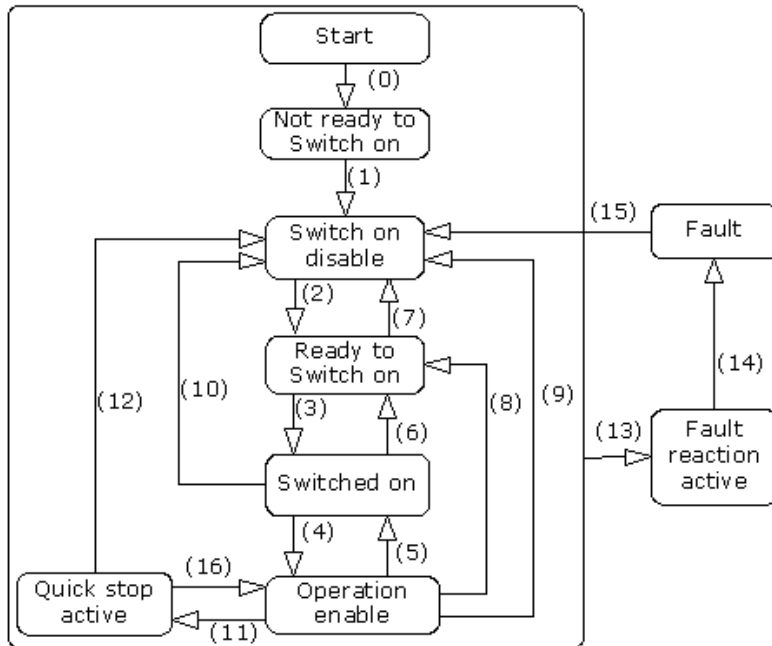

NMT status	Name
Not ready to Switch On	The hardware and Stack of the CANopen device are initialized in this state.
Switch on disable	The current device state does not allow switching on of the device.
Ready to switch on	Ready to change to the "Switch on" state any time.
Switch on	Ready for enabling an operation ("Operation enable" state). A RUN command can be executed anytime.
Operation enabled	Motor is running.
Quick stop active	Motor is being stopped, or it has been stopped.

The table below presents the inverter operation according to the change of states.

Transition	Event	Action
0	Automatic change	Performs self-diagnosis and initializes parameters
1	Automatic change	CANopen communication enabled
2	Change to Operation Mode	None
3	On receiving the "Switch on" command	None
4	On receiving the "Enable Operation" command	Motor drive
5	On receiving the "Disable Operation" command	Maintains the current inverter status. Any commands, including a "STOP" command, will not be accepted.
6	On receiving the "Shut Down" command	If the motor has been running, a free run stop will be performed.
7	On receiving "Disable voltage" command	None
8	On receiving the "Shut Down" command	A free run stop is performed.
9	On receiving "Disable voltage" command	A free run stop is performed.
10	On receiving "Disable voltage" or "Quick Stop" command	A free run stop is performed.
11	On receiving "Quick Stop" command	Speed is reduced according to the deceleration time set for the Quick Stop.
12	On receiving "Disable voltage" command	A free run stop is performed.
13	When the inverter has tripped	Executes a trip sequence
14	Automatic change	Executes a trip sequence
15	On receiving a "Reset" command or Trip is released	Enters the "Switch on disable" state.
16	On receiving the "Enable operation" command	Motor runs again.

6.1.2 CiA 402 SDO

► Error codes (Object : 0x603F)

When the inverter has tripped, this object is used to identify the type of trip.

Index	Sub-index	Name	Type	Property	Unit	Range
0x603F	-	Error code	U16	R	-	-

The table below presents the error code numbers that are returned for the inverter trips.

	Value	Description	Value	Description
Data	0x0000	None	0x7120	No Motor Trip
	0x1000	Untitled	0x8401	Speed Dev Trip
	0x2220	Inverter OLT	0x8402	Over Speed
	0x2310	OverCurrent1	0x9001	External Trip
	0x2330	Ground Trip	0x9002	BX
	0x2340	OverCurrent2	0xFF01	Ethermal
	0x3130	In Phase Open	0xFF03	Out Phase Open
	0x3210	Over Voltage	0xFF04	Over Load
	0x3220	Low Voltage	0xFF05	Under Load
	0x4000	NTC Open	0xFF06	Thermal Trip
	0x4310	Over Heat	0xFF07	Pre PID Fail
	0x5000	HW Diag	0xFF0A	Lost Command
	0x5450	Fuse Open	-	-

► Control Word (Object: 0x6040)

This object used to operate the inverter.

Index	Sub-index	Name	Type	Property	Unit	Range
0x6040	-	Control word	U16	RW	-	-

This object is not available if "CM-11 (Profile Sel)" is set to "1 (LS Device Profile (PDO3))."

The Bit composition below presents the bit command of the Control Word.

Bit	Description
0	Switch on
1	Enable voltage
2	Disable quick stop
3	Enable operation
4	Ramp function generator disable
5	Ramp function generator stop
6	Ramp function generator zero
7	Reset fault
8	Halt
9	Not used
10	Reserved
11~15	Not used

The state of Finite State Automation (FSA) explained in "Chapter 6.1.1" can be modified by changing the value of the control word into bit information related to the device operation command according to values of Bits 0–3 and Bit 7.

For example, the control word must be "0XxxxF (xxxx xxxx xxxx 1111)" to change the FSA state to "Operation enabled" in the table below (for the transition #4).

Command	7	3	2	1	0	Refer to Chapter 6.1.1 FSA	
	Fault reset	Enable operation	Quick stop disable	Enable voltage	Switch on	Transformed value	Status
Shutdown	0	X	1	1	0	2, 6, 8	Ready to switch on
Switch on	0	0	1	1	1	3	Switched on
Disable Voltage	0	X	X	0	X	7, 9, 10,12	Switch on disabled
Quick Stop	0	X	0	1	X	7, 10, 11	-
Disable Operation	0	0	1	1	1	5	Switched on
Enable Operation	0	1	1	1	1	4, 16	Operation enabled
Fault Reset		X	X	X	X	15	Switch on disabled

The "X" symbol means that this value does not make any difference (whether it is set to "0" or "1").

The bits between bit 4 and bit 7 are command bits that are operated in Operation Mode.

Bit	Value	Description
4 (Enable Ramp)	0	Maintain the previous operational state
	1	Operate the inverter by the command bits
5 (Unlock Ramp)	0	Hold the output frequency
	1	Drive up to the target frequency
6 (Reference Ramp)	0	Set the target frequency to "0"
	1	Set as the target frequency
8 (Halt)	X	Not used

► **Status Word (Object: 0x6041)**

This object indicates the current state of the current device.

Index	Sub-index	Name	Type	Property	Unit	Range
0x6041	-	Status word	U16	RO	-	-

This object is not available if "CM-11 (Profile Sel)" is set to "1 (LS Device Profile (PDO3))."

The bit composition below presents the command by bits of the Status Word.

Bit	Description
0	Ready to switch on
1	Switched on
2	Operation enabled
3	Fault (Trip)
4	Voltage enable
5	Quick stop
6	Switch on disable
7	Warning
8	Not used
9	Remote
10	Target reached
11	Internal limit active
12–15	Not used

The table below presents the bit values for Bits 0–3, Bit 5, and Bit 6 by the device's FSA state.

Status Word	PDS FSA State
xxxx xxxx x0xx 0000	Not ready to switch on
xxxx xxxx x1xx 0000	Switch on disable
xxxx xxxx x01x 0001	Ready to switch on
xxxx xxxx x01x 0011	Switch on
xxxx xxxx x01x 0111	Operation enabled
xxxx xxxx x00x 0111	Quick stop active
xxxx xxxx x0xx 1111	Fault reaction active
xxxx xxxx x0xx 1000	Fault

► VI Target Velocity (Object: 0x6042)

This object sets the target speed.

Index	Sub-index	Name	Type	Property	Unit	Range
0x6042	0	VI target velocity	U16	RW	rpm	-30000 -30000 (-) Reverse (+) Forward

This object is not available if "CM-11 (Profile Sel)" is set to "1 (LS Device Profile (PDO3))."

► VI Velocity Demand (Object: 0x6043)

This object displays the output speed of the current inverter.

Index	Sub-index	Name	Type	Property	Unit	Range
0x6043	0	VI velocity demand	U16	RO	rpm	-30000 -30000 (-) Reverse (+) Forward

This object is not available if "CM-11 (Profile Sel)" is set to "1 (LS Device Profile (PDO3))."

► **VI Control Effort (Object: 0x6044)**

This object that displays the operation speed of the current motor.

If the inverter is operated in "V/F" or "Sensorless" mode, the motor speed is equal to the output speed of the inverter.

Index	Sub-index	Name	Type	Property	Unit	Range
0x6044	0	VI control effort	U16	RO	rpm	-30000 -30000 (-) Reverse (+) Forward

This object is not available if "CM-11 (Profile Sel)" is set to "1 (LS Device Profile (PDO3))."

► **VI Velocity Acceleration (Object: 0x6048)**

This object sets the Acceleration Time.

As shown in the following figure, this object determines the acceleration time with a combination of the Delta Speed and Delta Time.

The Delta Speed is fixed to the maximum speed to maintain a stable inverter operation.

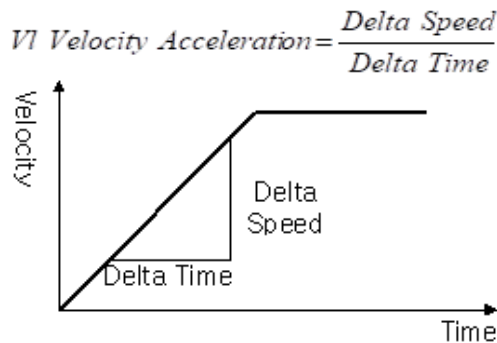

Transfer characteristic of the velocity acceleration

Index	Sub-index	Name	Type	Property	Unit	Range
0x6048		VI velocity acceleration	-	-	-	-
	0	Number of entries	U8	RO	-	-
	2	Delta Time	U16	RO	sec	0.0~600.0

This object is not available if "CM-11 (Profile Sel)" is set to "1 (LS Device Profile (PDO3))."

► VI Velocity Deceleration (Object: 0x6049)

This object sets the Deceleration Time.

As shown in the following figure, this object determines the deceleration time with a combination of the Delta Speed and Delta Time.

The Delta Speed is fixed to the maximum speed to maintain stable inverter operation.

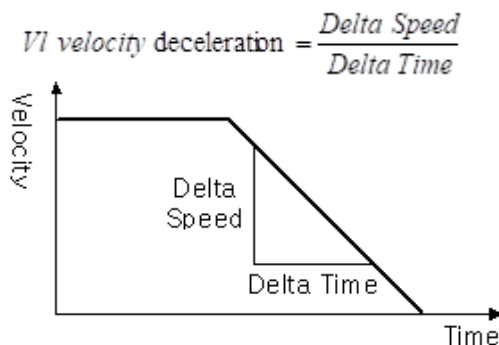

Transfer characteristic of the velocity deceleration

Index	Sub-index	Name	Type	Property	Unit	Range
0x6049		VI velocity deceleration	-	-	-	-
	0	Number of entries	U8	RO	-	-
	2	Delta Time	U16	RO	sec	0.0~600.0

► **vI velocity Quick Stop (Object :0x604A)**

This object sets the Quick Stop time.

As shown in the following figure, this object determines the Quick Stop deceleration time with a combination of the Delta Speed and Delta Time.

The Delta Speed is fixed to the maximum speed to maintain stable inverter operation.

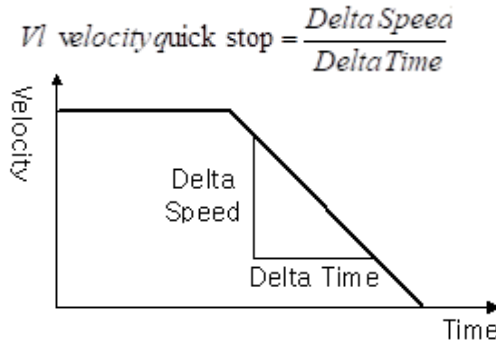

Transfer characteristic of the quick stop

Index	Sub-index	Name	Type	Property	Unit	Range
0x604A		V _I velocity quick stop	-	-	-	-
	0	Number of entries	U8	RO	-	-
	2	Delta Time	U16	RW	sec	0.0~600.0

6.1.3 SDO for G100 Inverter Operation

► **Common Area SDO Address**

- Inverter Monitoring Area

The inverter monitoring area refers to the read-only common area parameters between the communication addresses 0h300–0h37F.

In CANopen communication, the index value is "0x4000" and the sub-index value is "communication address - 0h300 + 1."

Ex.) If the value at communication address "0h0310" has to be read, the index is "0x4000" and the sub-index is "0x11" for the data.

- Inverter Control Area

The inverter control area refers to the common area parameters that are dedicated for control, between the communication addresses 0h380–0h3DF. In CANopen communication, the index value is "0x4001" and the sub-index value is "last two digits of the communication address + 1."

Ex.) If the value at communication address "0h0389" has to be read, the index is "0x4001" and the sub-index is "0x0A" for the data.

- Inverter Memory Control Area

The inverter memory control area refers to the common area parameters for memory control, between the communication addresses 0h3E0–0h3FF. In CANopen communication, the index value is "0x4002" and the sub Index value is "communication address - 0h3E0 + 1."

Ex) If the value at communication address "0h03E1" has to be read, the index is "0x4002" and the sub Index is "0x02" for the data.

⚠ Caution

Before setting a parameter to utilize a memory control area address, ensure that the previous setting value is "0." If the setting value is not "0," you must set it to "0" first, then change the value again before the change can take effect. The parameter setting change will not take effect if you change a parameter value that is not "0" to a value other than "0." Ex.) If the parameter to save the data at "0h03E0 (index:0x4002, sub-index: 0x01)" had been set to "1 (Yes)," you must first change the setting to "0 (No)," then set it again to "1 (Yes)" before the parameter change can take effect.

► Keypad Parameter Area SDO Address

The keypad parameters are indexed by group. The Sub-Index is the code number.

The table below presents the index values by Group.

Index	Group name
0x4010	DR group
0x4011	BA group
0x4012	AD group
0x4013	CN group
0x4014	IN group
0x4015	OU group
0x4016	CM group
0x4017	AP group
0x401A	PR group
0x401B	M2 group
0x401C	SPS group (Operation group)

Ex.) To read BA-70 (ACC. Time-1) which is the value of code 70 in the BA group, read the value at index "0x4011" and sub-index "70."

6.2 PDO

PDOs for frequency converters are available, within the CiA 402 Drive and Motion Control device profile.

6.2.1 RPDO

▶ RPDO1 Parameter (0x1400)

Index	Sub-index	Name	Type	Property	Unit	범위
0x1400	0	RPOD1 Parameter	U8	RO	-	-
	1	COB ID	U32	RW	-	-
	2	Transmission Type	U8	RW	-	-

A COB-ID is the unique CAN ID value of the PDO.

The table below presents the transmission type values.

Transmission Type Value	Description
0	Transmits an RPDO when a synchronous transaction occurs. The RPDO is transmitted only if the current RPDO data has changed from the previous RPDO data. (COS: Change of state)
1~240	Transmits an RPDO when the set number of synchronous transactions are received.
252~253	Not Supported
255	Transmits an RPDO by asynchronous (event-triggered) transmissions.

▶ RPDO3 Parameter (0x1402)

Index	Sub-index	Name	Type	Property	Unit	Range
0x1402	0	RPOD1 Parameter	U8	RO	-	-
	1	COB ID	U32	RW	-	-
	2	Transmission Type	U8	RW	-	-

A COB-ID is the unique CAN ID value of the PDO.

6.2.2 RPDO MAPPING

The G100 CANopen RPDO Map is fixed, and does not allow modification by users.

► RPDO1 Mapping(0x1600)

Index	Sub-index	Name	Type	Property	Unit	Range
0x1600	1	PDO Mapping Entry1 0x6040 Control word	U32	RO	-	-
	2	PDO Mapping Entry2 0x6042 VI Target Velocity	U32	RO	-	-

► RPDO3 Mapping(0x1602)

Index	Sub-index	Name	Type	Property	Unit	Range
0x1602	1	Input1 0x3010	U32	RW	-	-
	2	Input1 0x3011	U32	RW	-	-
	3	Input1 0x3012	U32	RW	-	-
	4	Input1 0x3013	U32	RW	-	-

6.2.3 TPDO

▶ TPDO1 Parameter(0x1800)

Index	Sub-index	Name	Type	Property	Unit	Range
0x1800	0	TPDO1 Parameter	U8	RO	-	-
	1	COB ID	U32	RW	-	-
	2	Transmission Type	U8	RW	-	-
	3	Inhibit Time	U16	RW	-	-
	5	Event Timer	U16	RW	-	-

A COB-ID is the unique CAN ID value of the PDO.

The transmission type for the G100 CANopen communication is fixed as 255 (0xFF, Asynchronous). The TPDO is transmitted at every Event Time.

▶ TPDO3 Parameter (0x1802)

Index	Sub-index	이름	Type	속성	단위	범위
0x1802	0	TPDO3 Parameter	U8	RO	-	-
	1	COB ID	U32	RW	-	-
	2	Transmission Type	U8	RW	-	-
	3	Inhibit Time	U16	RW	-	-
	5	Event Timer	U16	RW	-	-

A COB-ID is the unique CAN ID value of the PDO.

The transmission type for the G100 CANopen communication is fixed as 255 (0xFF, Asynchronous). The TPDO is transmitted by the event trigger operation. The TPDO is transmitted If the data has not changed within the time set as the Event Time. If the data has changed within the Event Time, the TPDO is transmitted after the Inhibit Time has passed.

6.2.4 TPDO MAPPING

The G100 CANopen TPDO map is fixed, and does not allow modification by users.

► TPDO1 Mapping (0x1A00)

Index	Sub-index	Name	Type	Property	Unit	Range
0x1A00	1	PDO Mapping Entry1 0x6041 Status word	U32	RO	-	-
	2	PDO Mapping Entry2 0x6044 VI Control Effort	U32	RO	-	-

► TPDO3 Mapping (0x1A02)

Index	Sub-index	Name	Type	Property	Unit	Range
0x1A02	1	Input1 0x3010	U32	RW	-	-
	2	Input1 0x3011	U32	RW	-	-
	3	Input1 0x3012	U32	RW	-	-
	4	Input1 0x3013	U32	RW	-	-

7 Inverter Parameters

7.1 List of Related Parameters

Code	parameter Name	Initial Value	Range
drv	Cmd Source	0(Fx/Rx-1)	0. Keypad
			1. Fx/Rx-1
			2. Fx/Rx-2
			3. RS485
			4. FieldBus
Frq	Freq Ref Src	0(Keypad-1)	0. Keypad-1
			1. Keypad-2
			2. V1
			3. Reserved
			4. V0
			5. I2
			6. Int 485
			7. Reserved
			8. Fieldbus
CM-06	FBus S/W Ver	-	-
CM-07	FBus ID	1	1~127
CM-09	FBus LED	-	-
CM-10	Opt Parameter1	0	0. 1Mbps
			1. 800Kbps
			2. 500Kbps
			3. 250Kbps
			4. 125Kbps
			5. 100Kbps
			6. 50Kbps
			7. 20Kbps

Code	parameter Name	Initial Value	Range
CM-11	Opt Parameter2	0 (CiA402 Profile)	0. (CiA 402 Profile) (Frequency Converter PDO1) 1. (LS Profile)
CM-31	Para Status-1	0x000A	0~0xFFFF
CM-32	Para Status-2	0x000E	0~0xFFFF
CM-33	Para Status-3	0x000F	0~0xFFFF
CM-34	Para Status-4	0x0000	0~0xFFFF
CM-51	Para Control-1	0x0005	0~0xFFFF
CM-52	Para Control-2	0x0006	0~0xFFFF
CM-53	Para Control-3	0x0000	0~0xFFFF
CM-54	Para Control-4	0x0000	0~0xFFFF
CM-94	Comm Update	0(None)	0. No 1. Yes
Pr-12	Lost Cmd Mode	0(None)	0. None 1. Free-Run 2. Dec 3. Hold Input 4. Hold Output 5. Lost Preset
Pr-13	Lost Cmd Time	1.0 sec	0.1 ~ 120.0 sec
Pr-14	Lost Preset F	0 Hz	Start Freq~Max Freq [Hz]

7.2 Basic Field Bus Parameters

7.2.1 Set Command Source for the Inverter–Cmd Source (drv)

drv	Cmd Source
-----	------------

This parameter sets the command source for the inverter operation.

Set "drv (Cmd Source)" to "4 (Fieldbus)" to send an operation or stop command to the inverter via the CANopen network communication.

7.2.2 Set Frequency Command Source for the Inverter–Freq Ref Src (Frq)

Frq	Freq Ref Src
-----	--------------

This parameter sets the frequency command source for the inverter operation.

Set "Frq (Freq Ref Src)" to "8 (Fieldbus)" to send the command frequency for the inverter operation via the CANopen network communication.

7.2.3 Set Station ID–Fbus ID (CM-07)

CM-07	FBus ID
CM-94	Comm Update

This parameter sets the Station ID for a CANopen network. The station number can be set to a number between 1–127.

The station ID cannot be duplicated. Ensure the station ID you will be using is not already occupied by another device in the network.

After changing the Station ID, the ERR LED on the CANopen communication module will flash at twice the interval of the CPU LED.

Because a CANopen-related parameter has been changed, you must run a communication update (Comm Update) to apply the changed station ID to the

CANopen communication module.



The changed station ID will be applied to the CANopen communication module only after you set "CM-94 (Comm Update)" to "1 (Yes)."

7.2.4 View Indicator LED States–Fbus Led (CM-9)

This parameter displays the operation status of the four LED indicators (BUS, NODE, ERR, and CPU) on the CANopen communication module.

On the keypad display, the status of the four LED indicators are displayed, in the order of BUS, NODE, ERR, and CPU, from left to right.

CM-9 (Fbus LED Status) – Ex.) 1101

LED	BUS (GREEN)	NODE (GREEN)	ERR (RED)	CPU (GREEN)
Status	ON	ON	OFF	ON
Keypad Segment				

7.2.5 Run Comm Update (CM-94)

CM-07	Station ID
CM-10	Baud rate
CM-11	Profile Sel
CM-94	Comm Update

After making changes to the station ID, baud rate, or the profile settings, the "CM-94 (Comm Update)" parameter must be set to "1 (Yes)" for the changes to take effect.

The changes in the station ID, baud rate, or the profile settings will be reflected in the CANopen communication module only after you run the Comm Update.

7.2.6 Set the Network Speed (Baud Rate)—Opt Parameter1 (CM-10)

CM-10	Opt Parameter1
CM-94	Comm Update

This parameter sets the network speed (baud rate) of a CANopen network. The baud rate can be set from "0 (1 Mbps)" through "7 (10kbps)."

When you configure the network speed, the baud rate must be set identically for all the devices connected to the network.

- 0 : 1 Mbps
- 1 : 800 kbps
- 2 : 500 kbps
- 3 : 250 kbps
- 4 : 125 kbps
- 5 : 100 kbps
- 6 : 50 kbps
- 7 : 20 kbps

After making changes to the "CM-10 (Baud rate)" setting, the ERR LED on the CANopen communication module will flash at twice the interval of the CPU LED.

Because a CANopen-related parameter has been changed, you must run a communication update (Comm Update) to apply the changed network speed to the CANopen communication module.

The "CM-94 (Comm Update)" parameter must be set to "1 (Yes)" before the new network speed (baud rate) can be applied to the CANopen communication module.

7.2.7 Set Profile—Opt Parameter2 (CM-11)

CM-11	Opt Parameter2
CM-94	Comm Update

This parameter sets the PDO communication profile.

- 0 : CiA 402 Drive and Motion Control Velocity Mode
(Frequency Converter PDO1)
- 1 : LS Device Profile (PDO3)

After making changes to the "CM-11 (Profile Sel)" parameter setting, the ERR LED on the CANopen communication module will flash at twice the interval of the CPU LED.

Because a CANopen-related parameter has been changed, you must run a communication update (Comm Update) to apply the changed profile to the CANopen communication module.

The "CM-94 (Comm Update)" parameter must be set to "1 (Yes)" before the new profile can be applied to the CANopen communication module.

If "CM-11 (Profile Sel)" is set to "0 (CiA 402 Profile (PDO1))," the ACC (acceleration time) and dEC (deceleration time) values cannot be set using the Keypad. They can be set only via addresses "0x6048 (VI velocity acceleration)" and "0x6049 (VI velocity deceleration)."

Addresses "0x6040 through 0x6048" will not be available for use if "CM-11 (Profile Sel)" is set to "1 (LS Device Profile (PDO3))."

7.2.8 View Communication Module Version—Fbus S/W ver (CM-06)

This parameter displays the version of the CANopen communication module that is installed on the inverter.

7.3 Parameter Setting for Periodic Communication

7.3.1 Set LS Profile Output Address—Para Status 1–4 (CM-31–34)

CM-11	Profile Sel
CM-31~34	Para status 1~4

You can configure four addresses (Para Status 1–4) and transmit the parameter values to the master device via the TPDO3 (Transmit PDO).

7.3.2 Set LS Profile Input Address–Para Status 1–4 (CM-51–54)

CM-11	Profile Sel
CM-51~54	Input 1~4

You can configure four addresses (Para Control 1–4) to receive data values transmitted from the master device via the RPDO3 (Receive PDO) and utilize the data for operating the inverter.

7.4 Parameter Setting for Lost Command

The G100 CANopen communication module decides that the inverter is in a "Lost Command" condition when the CANopen PDO communication is lost for the time set at Pr-13. The "Lost Command" occurs only when one or more of the operation command source is set as the Fieldbus communication.

7.4.1 Lost Command Operation–Lost Cmd Mode (Pr-12)

Drv	Cmd Source
Frq	Freq Ref Src
Pr-12	Lost Cmd Mode
Pr-13	Lost Cmd Time
Pr-14	Lost Preset F

The Lost CMD Mode (Pr-12) parameter is used to decide the operation mode of the inverter when a lost command occurs due to a PDO communication loss which exceeds the time set as the lost command decision time.

To utilize the lost command operation, the "drv" parameter must be set to "4 (Fieldbus)" or the "Frq" parameter must be set to "8 (Fieldbus)."

If the command is lost, the inverter is operated according to one of the operation methods you have selected. The table below presents the available operation methods.

Set value		Description
0	None	The speed reference immediately becomes the operation frequency without any protective operation.
1	Free-Run	The inverter output is blocked. The motor performs a free-run.
2	Dec	The inverter decelerates and then stops according to the time set at "Pr-07 (Trip Dec Time)."

Set value		Description
3	Hold Input	The inverter continues operating according to the speed reference input received before the loss of speed.
4	Hold Output	The inverter continues operating according to the frequency reference received before the loss of speed.
5	Lost Preset	The inverter operates at the frequency set at "Pr-14 (Lost Preset F)."

7.4.2 Command Loss Decision Time–Lost Cmd Time (Pr-13)

Drv	Cmd Source
Frq	Frq Ref Src
Pr-12	Lost Cmd Mode
Pr-13	Lost Cmd Time

The inverter decides that the communication command is lost If the PDO communication loss lasts longer than the "communication command loss decision time."

To utilize the lost command operation, the "drv" parameter must be set to "4 (Fieldbus)" or the "Frq"parameter must be set to "8 (Fieldbus)."

The lost command operation will not be performed If the communication is resumed within the "communication command loss decision time" and the normal inverter operation is restored (it will not be regarded as an error).

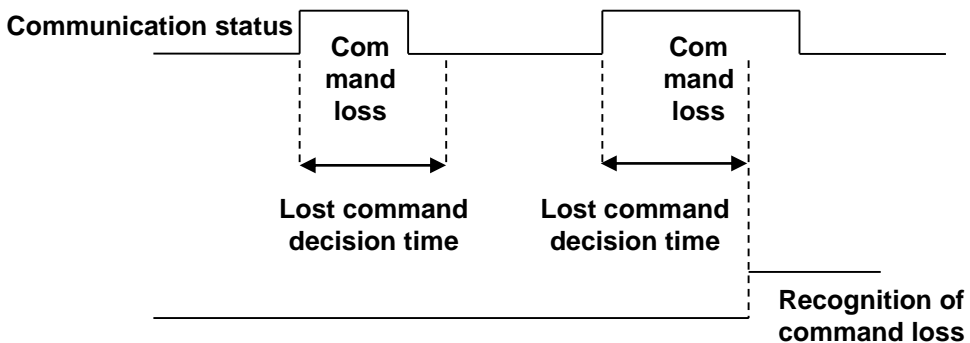

Product Warranty

Warranty Information

After purchasing and installing the product, fill out the following information in detail. This information can be used to get the benefits of a warranty when the product becomes faulty during the warranty period.

Maker	LS ELECTRIC Co., Ltd.	Date of Installation	
Model No.	CCAN-G100	Warranty Period	
Customer Information	Name (or company)		
	Address		
	Contact Info.		
Sales Office (Distributor)	Name (or company)		
	Address		
	Contact Info.		

Warranty Service Information

Warranty period is 12 months after installation or 18 months after manufactured when the installation date is unidentified. However, the guarantee term may vary on the sales term

IN-WARRANTY service information

If the defective part has been identified under normal and proper use within the guarantee term, contact your local authorized LS distributor or LS Service center.

OUT-OF WARRANTY service information

The guarantee will not apply in the following cases, even if the guarantee term has not expired.

- Damage was caused by misuse, negligence or accident.
- Damage was caused by abnormal voltage and peripheral devices' malfunction (failure).
- Damage was caused by an earthquake, fire, flooding, lightning, or other natural calamities.
- When LS nameplate is not attached.
- When the warranty period has expired.

Visit Our Website

Visit us at <https://www.lselectric.co.kr> for detailed service information.

Manual Revision History

Revision History

No	Date	Edition	Changes
1	2020.01	V1.0	First release