

**LASTONE** 恒一

电能治理 恒心致远

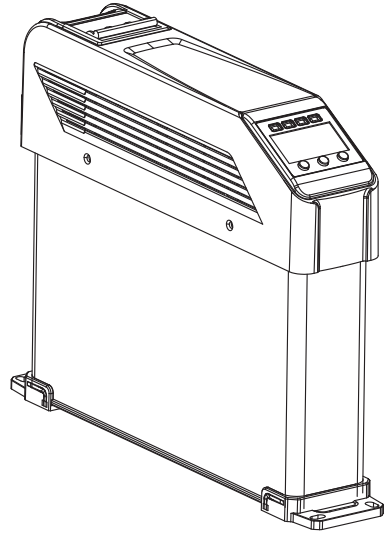

## HY Series

Intelligent combination type low voltage  
power capacitor compensation installation

user's manual

## Notice

This manual is only for person who is responsible for installation , maintenance and operation .

1. This type capacitor bank (compensation bank) must use knife switch or MCCB
2. To install this product, connection wire must be strictly according to this manual
3. Before power on, all terminals must be tightened (reminder : transport vibration may make screw loose)
4. Before operation, please confirm the current sampling , communication , control function is normal .
5. The environment and power supply must meet the requirement of product , this product can not used on the place where harmonic more than 5%, when the harmonic more than 5%,please use our harmonic restraining series products .

# Contents

1 General	1
2 Types and meanings	1
3 Exterior and mounting size	1
4 Connection diagram (mounting distance between two capacitors $\geq 50\text{mm}$ )	2
4.1 Connection diagram(with 580 controller)	2
4.2 Connection diagram (with 582/JKGHY controller)	2
4.3 Connection diagram (with JKGHY583 controller)	3
4.4 Connection diagram of three-phase mixed compensation (without controller)	3
4.5 Connection diagram of three-phase compensation (without controller)	4
4.6 Single unit connection diagram	4
5 Capacitors switching indicator light wiring diagram	5
6 Connection of power line	5
7 connection of grounding line	5
8.1 check before turning on the switch	5
8.2 When power switch is turned on , You should set the ratio of primary current transformer	5
9 Running and Operation Instructions of three phase compensation	6
10 Running and Operation Instructions of Phase-splitting compensation	8
11 Manual switching test	10
12 Parameter factory default setting	10
13 Plug-type communication line specification table	10
14 Analysis of common faults	11
15 The meaning of the Warning code	12

Intelligent combination type low voltage power capacitor compensation installation

1 General

Working in a 0.4kv low voltage network, the intelligent reactive compensation installation (intelligent combination type low voltage energy-saving power capacitor) can reduce line loss, raise power factor, improve power quality, and energy-saving. It combines advanced technologies like modern measurement and control, power electronics, network communication, auto-control, and power capacitor. Compared with traditional reactive compensation installations, it is smaller, cheaper, more cost-saving, more flexible, more convenient to maintain, with less power consumption, longer life span and more reliability, meeting a higher demand of modern power grid for reactive compensation.

2 Types and meanings

HY B A □□-□/□/□(□+□)-I

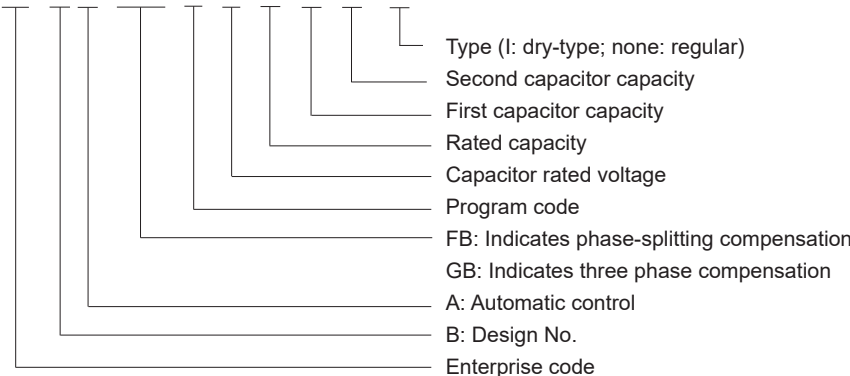

3 Exterior and mounting size

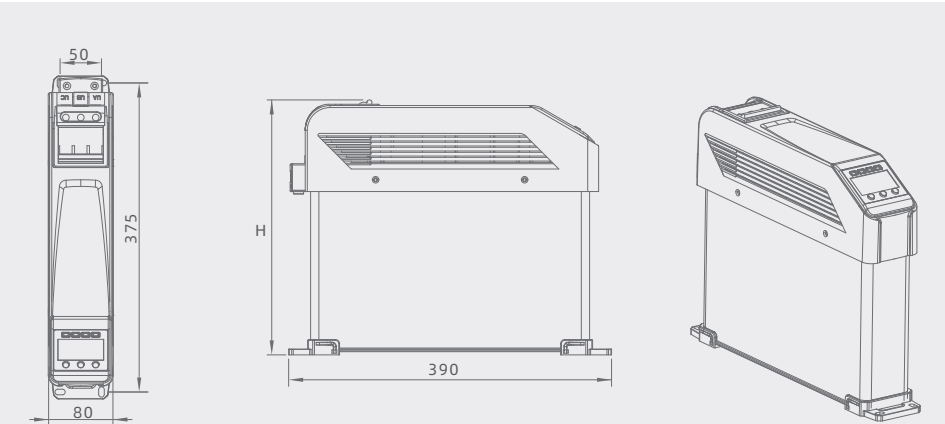

Note: The installation size is 50mm × 375mm.  
The installation distance between two capacitors is ≥50mm

## 4.1 Connection diagram (with JKGHYBA580 controller)

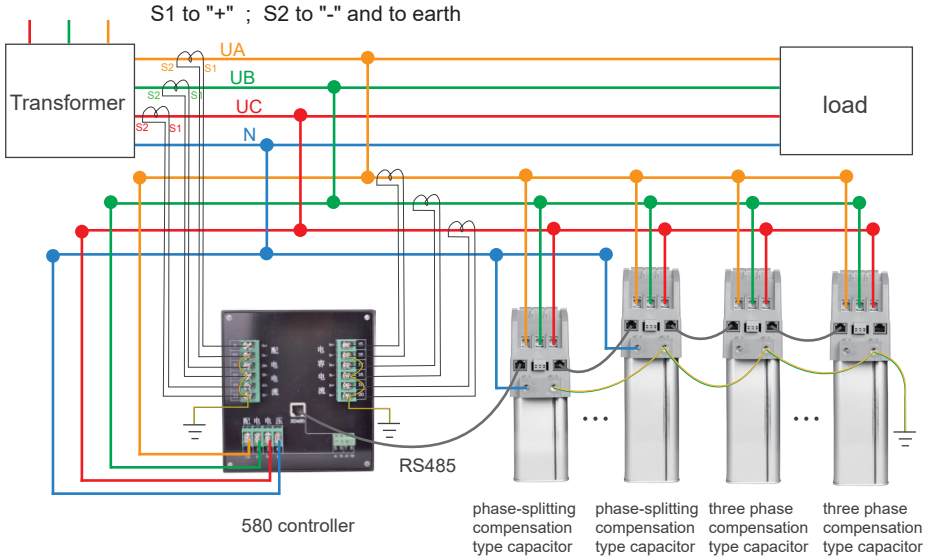

note : ( Phase-splitting + three phase compensation )  $\leq$  20 sets

## 4.2 Connection diagram (with JKGHY582/JKGHY controller)

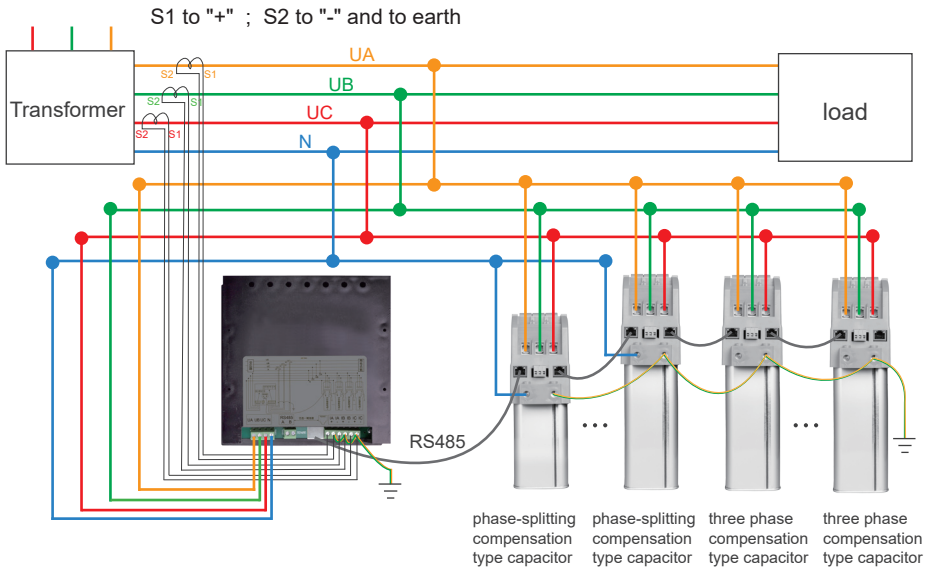

note : ( Phase-splitting + three phase compensation )  $\leq$  20 sets

### 4.3 Connection diagram (with JKGHY583 controller)

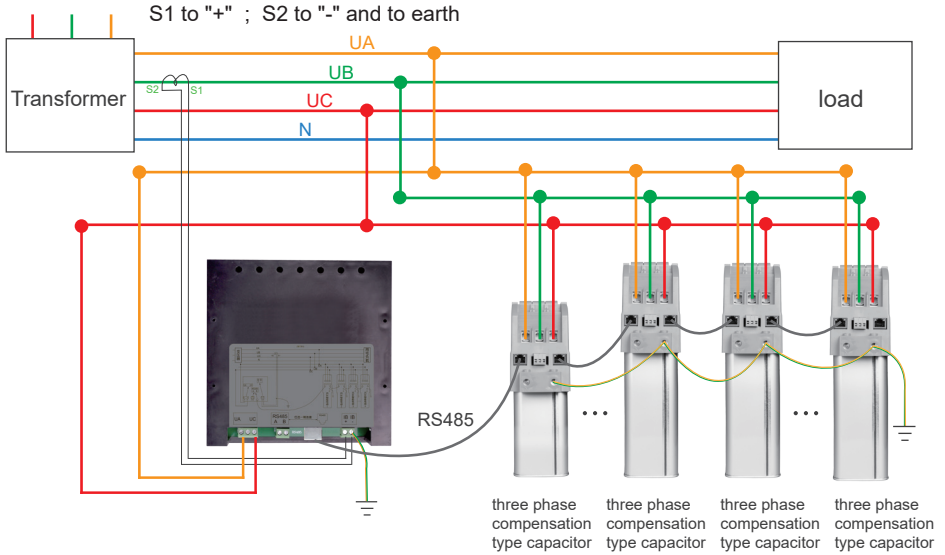

note : three phase compensation  $\leq 20$  sets

### 4.4 Connection diagram of three-phase mixed compensation (without controller)

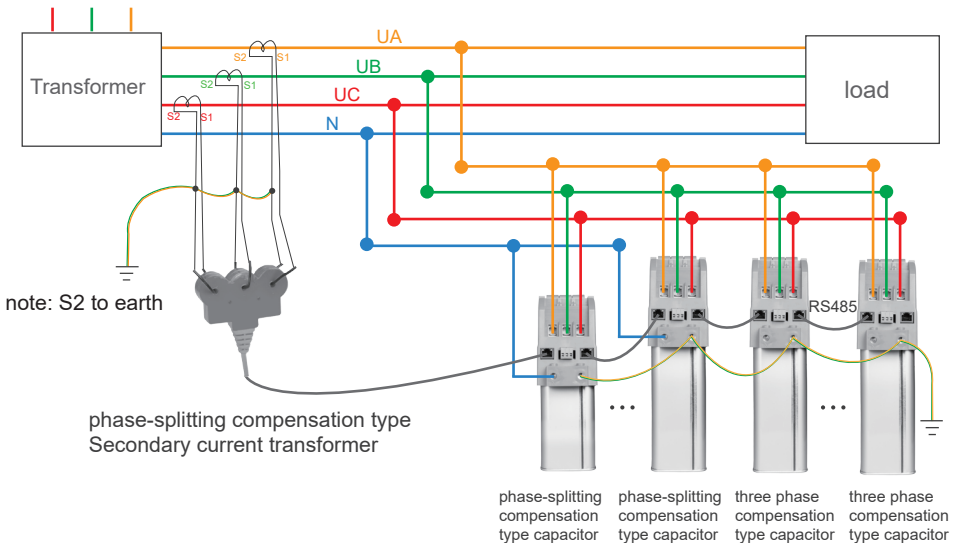

note : ( Phase-splitting + three phase compensation )  $\leq 30$  sets

## 4.5 Connection diagram of three phase compensation (without controller)

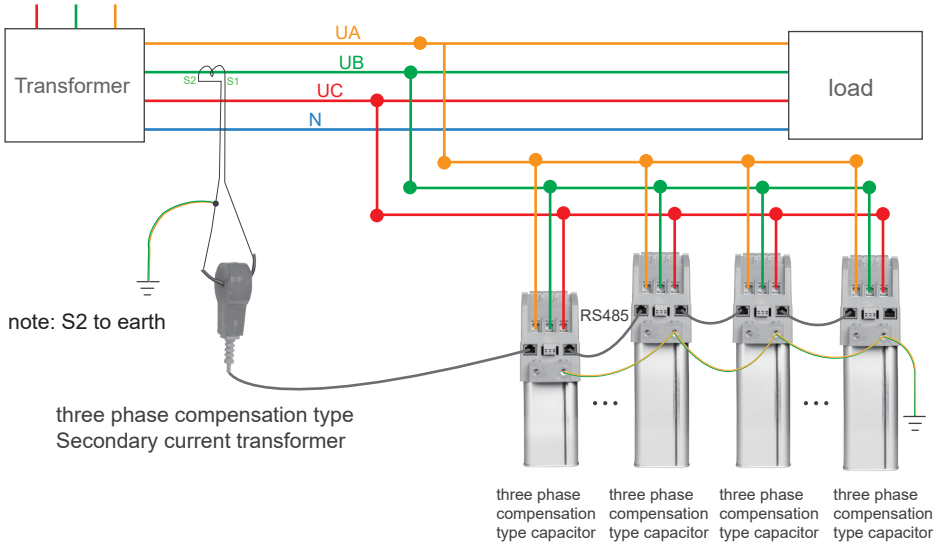

note : three phase compensation type  $\leq 30$  sets

## 4.6 Single unit connection diagram

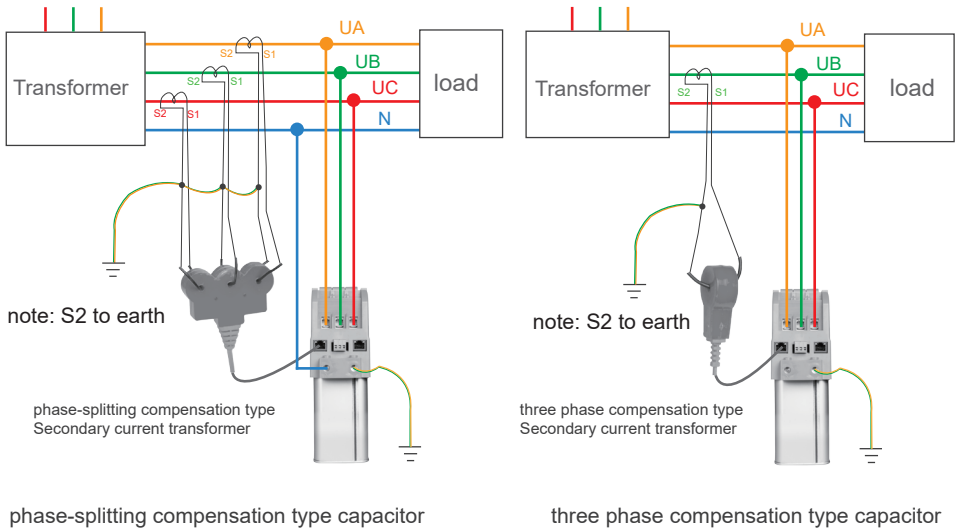

## 5 Capacitors switching indicator light wiring diagram

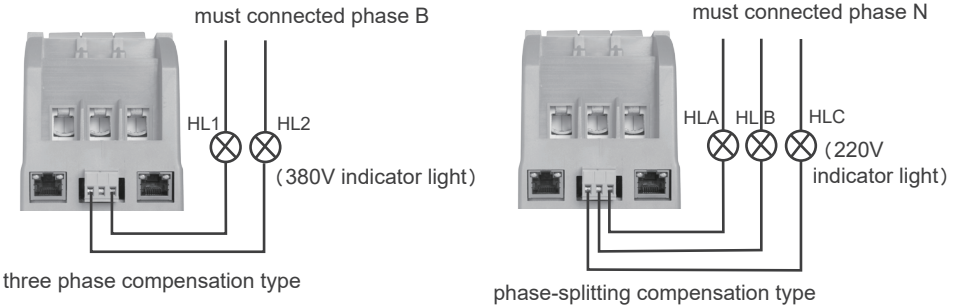

note: Indicator light line uses 0.75mm<sup>2</sup> multi-core copper cable.

## 6 Connection of power line

the total capacity of capacitor	1~19 kvar	20~39 kvar	40~70 kvar
Multi-core copper wire cross-sectional area	10mm <sup>2</sup>	16mm <sup>2</sup>	25mm <sup>2</sup>

**Caution:** select the copper cable with corresponding specification. Fasten the screw and pull the power line to ensure the connection is secure enough; otherwise, the connection end will become excessively heated, causing the capacitor to be damaged. Phase-splitting compensation must be connected to neutral line, whose diameter is the same as three phase power incoming line.

## 7 Connection of grounding line

Grounding line uses single-strand copper cable with cross section not less than 2.5mm<sup>2</sup>. Grounding line must be well connected and connects to the external grounding side.

### 8.1 Check before turning on the switch

- If line is well connected, phase sequence is connected right?
- Check using multimeter buzzer to see if short-circuit occurs between phase lines, phase and grounding line.
- Signal line plug-type connection must be secure and reliable.

### 8.2 When power switch is turned on (set the ratio of primary current transformer in the master by manual)

When power switch is turned on, the interface displays "HY □□□", after approx. 1s, the systems enters communication network mode, the interface displays : "- - -", within 60s, each capacitor show "Adr001"、"adr002"... address code, it means communication networking successful.

Without controller, systems assigned one capacitor as master automatically, master address is "Ad-000", slave address will be 001, 002 ...

When the master display "000" after approx. 180s, it will enter automatic running mode based on factory default value 100 (100 is ratio of primary current transformer)

If the ratio of primary current transformer is not 100, the master will enter automatic identification of variable ratio of primary current transformer mode, it takes long time (our suggestion: set the ratio of primary current transformer in the master by manual, eg: 600/5 set 120)

Setting method: for three phase compensation type, see page no.7, under the setting mode, interface display "05-100", then set the ratio; for phase-splitting compensation type, see page no.9, under setting mode, interface display "04-100", then set the ratio.

with controller (please set the ratio of primary current transformer in the controller, for example 500/5 set 100) setting method: see manual of controller, after setting, system enters the automatic running status.



## 9.1 Introduction to operator interface of liquid crystal 3-phase compensation

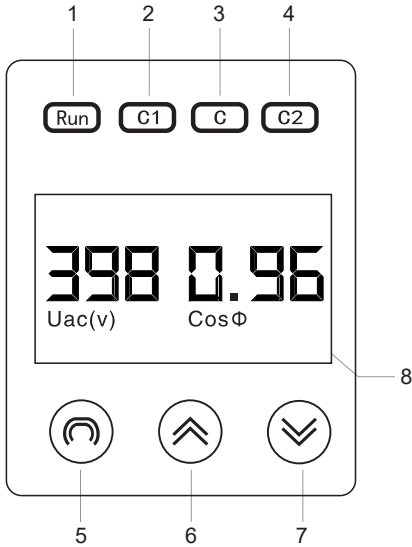

No.	LED/ name	Instruction
1	Run	System is in auto running status when green indicator light is on
		System is in manual running status when red indicator light is on
		System is in Analog status when double-color indicator light is on
2	C1	the first capacitor is working
3	C	none
4	C2	the second capacitor is working
5	menu	press menu button(automatic state:circular display parameters)(under manual,debugging,setting state,back to automatic state) usage of combination keys see operating instructions
6	up	press up (setting state),cutting in manually (manual state)
7	down	press down (setting state) ,cutting off manually(manual state)
8	LCD	display of faults, setting and measuring parameters.

## 9.2 automatic running status, press to query parameters and implication

Automatic running status, with controller, default display see legend no.6,and show address respectively

without controller, default display of master see legend no.1,default display of slave see legend no.6

Automatic running status, press  , circular display parameters see following legend

No.	1	2	3	4	5
Display legend	<b>380 0.86</b> Uac(V) cosΦ	<b>2.50 82.3</b> Ib(A) Q(kvar)	<b>045 045</b> t1(°C) C1 t2(°C) C2	<b>00.0 00.0</b> IA(A) C1 IB(A) C2	<b>00.0 - 00</b> IC(A) C1 CODE C2
Description	UAC(V), power factor	secondary current value of phase B(A), total reactive power	temperature of capacitor (C1) & (C2)	Current of phase A and phase B capacitor (A)	Current of phase C capacitor, switch on and off error code

No.	6	7	8	9	10
Display legend	<b>Adr 00 1</b>	<b>7Hd - 0.0</b> Uac(V)	<b>7Hd - 0.0</b> Ib(A)	<b>Err - 00</b>	<b>Srr - 00</b>
Description	The capacitor communication address	THDV (V)(Uac)	THDI (Ib)	warning code details see page no.12	Quantity of slave

Remark: as master, eg. " Srr-00" show quantity of slave, as slave, eg. " " Srr-00" without any meaning.

### 9.3 setting status (three phase compensation type)

Systems is under automatic running status, ("running" LED indicator light in green ),simultaneously press up and menu button, and then released immediately, systems enters setting status.

And then press "menu" button,contents display relative data according to following legend.

Press "up" button to increase the setting parameters, press "down" button to decrease the setting parameters, setting parameters are saved automatically. press "menu" button to return to automatic running status.

No.	1	2	3	4	5
Display legend	01- 20.0 C1 Q(kvar)	02- 10.0 Q(kvar) C2	03- 0.96 cosΦ	04- 0 10	05- 100
Description	Capacity of capacitor (C1) (Kvar)	Capacity of capacitor(C2) (Kvar)	Power factor switching threshold	Switching time delay(S)	Ratio of current transformer

No.	6	7	8	9	10
Display legend	06 001	07 060 tc1(°C)	Over voltage 08- 4 32 Uac(V)	Over voltage 09- 4 49 Uac(V)	Under voltage 10- 2 90 Uac(V)
Description	The capacitor communication address	Temperature protection value (°C)	I grade over voltage protection value (V)	II grade over voltage protection value (V)	Under voltage protection value (V)

No.	11	12	13	14	15
Display legend	Over voltage 11- 0 05 Uac(V)	Over current 12 - 0 10 Ib(A)	13 - 0 10	14 - 1.3 IA(A) IC(A) IB(A) C1 C2	under current 15 - 100 Ib(A)
Description	over THDV protection threshold	Over THDI protection threshold	Alarm time judgment (S)	Over current multiples of capacitor	Secondary down-current threshold (mA)

Remark: Legend No. 08,09 (over voltage protection)

Voltage exceed I grade protection value, capacitor didn't switch on and off, stop to response

Voltage exceed II grade protection value, capacitors which switched on will be cutted off one by one automatically, quit working

No.	16
Display legend	16 090
Description	Capacitor discharge time (S)

Remark: Legend No. 06(The capacitor communication address)

Under the legend no.06 interface, press "menu" button, just skip it, systems is in automatic communication internet status.

if press "up" or "down" button, it will be considered as manual intervention, when manual intervention, the biggest value ≤20 or (≤32),it based on the biggest internet quantity of controller or master

After manual intervention, if need to enter automatic communication internet status manually, please set value :255

Remark: Legend No. 16(capacitor discharge time)

Combination switch type: factory default is 30s(adjusted from 30s to 180s)

Synchronous switch type :factory default is 90s(adjusted from 90s to 180s)

### 10.1 Introduction to operator interface of liquid crystal Phase-splitting compensation



No.	LED/name	Instruction
1	Run	System is in auto running status when green indicator light is on System is in manual running status when red indicator light is on System is in Analog status when double-color indicator light is on
2	Ca	the capacitor of phase A is working
3	Cb	the capacitor of phase B is working
4	Cc	the capacitor of phase C is working
5	menu	press menu button(automatic state:circular display parameters)(under manual,debugging,setting state,back to automatic state) usage of combination keys see operating instructions
6	up	press up (setting state),cutting in manually (manual state)
7	down	press down (setting state) ,cutting off manually(manual state)
8	LCD	display of faults, setting and measuring parameters.

### 10.2 automatic running status, press to query parameters and implication

Automatic running status, with controller, default display see legend No.19, and show address respectively.  
without controller, default display of master see legend No.1,default display of slave see legend No.19.  
Automatic running status, press "menu",circular display parameters see following legend.

No.	1	2	3	4	5	6	7	8	9
Display legend	220 0.86 U(V) phase A cosΦ			1.46 16.3 I(A) phase A Q(kvar)		7HA - 7.8 U(V) phase A			
Description	display voltage and power factor of phase A,B and C in turn			display secondary current and reactive power of phase A,B and C in turn		display THDV of phase A,B and C in turn			

No.	10	11	12	13	14	15	
Display legend	7HA - 2.3 I(A) phase A		035 035 t(°C)		20.5 20.5 CIA(A) phase A phase B		IC(A) CODE 20.5 - 7.7 phase C
Description	display THDI of phase A,B and C in turn		temperature of capacitor		current of phase A and B capacitor		current of phase C capacitor, switch on and off error code

No.	16	17	18	19	20	
Display legend	ErrA - 20 phase A			Adr 00 1		Srr - 09
Description	Warning code of Phase A,B and C in turn, details see page no.12			The capacitor communication address		Quantity of slave

Remark: Legend no.19, adr-005 means address of slave is 005; ad-001 means independent operation or offline. Ad-000 means master. Legend no.20, as master, eg: " Srr-00 " show quantity of slave, as slave, eg: " Srr-00 " without any meaning.

### 10.3 setting status (phase-splitting compensation type)

Systems is under automatic running status, ("running" LED indicator light in green ),simultaneously press up and menu button, and then released immediately, systems enters setting status.

And then press "menu" button, contents display relative data according to following legend.

Press "up" button to increase the setting parameters, press "down" button to decrease the setting parameters, setting parameters are saved automatically. press "menu" button to return to automatic running status.

No.	1	2	3	4	5
Display legend	01- 20.0 phase C Q(kvar)	02- 0.96 cos $\Phi$	03- 0 10	04- 100	05- 100
Description	capacity of capacitor(kvar)	Power factor switching threshold	Switching time delay(S)	ratio of current transformer	The capacitor communication address

No.	6	7	8	9	10
Display legend	06 - 060 t(°C)	over voltage 07- 250 U(V)	over voltage 08- 260 U(V)	under voltage 09- 170 U(V)	over voltage 10- 005 U(V)
Description	temperature protection value (°C)	I grade over voltage protection value (V)	II grade over voltage protection value (V)	down voltage protection value (V)	over THDV protection threshold

No.	11	12	13	14	15
Display legend	over current 11 - 0 10 I(A)	12 - 0 10	over current 13 - 13 CIA(A) IA phase A	under current 14 - 100 I(A)	15 030
Description	Over THDI protection threshold	Alarm time judgment(S)	Over current multiples of capacitor	Secondary down-current threshold (mA)	capacitor discharge time(s)

Remark: Legend No.07, 08 (over voltage protection)

Voltage exceed I grade protection value, capacitor didn't switch on and off, stop to response.

Voltage exceed II grade protection value, capacitors which switched on will be cutted off one by one automatically, quit working.

No.	16
Display legend	Imbalance 16 - 005
Description	voltage imbalance degree

Remark: Legend No.05 (The capacitor communication address)

Under the legend No.05 interface, press "menu" button, just skip it, systems is in automatic communication internet status

if press "up" or "down" button, it will be considered as manual intervention, when manual intervention, the biggest value $\leq 20$  or ( $\leq 32$ ),it based on the biggest internet quantity of controller or master.

After manual intervention, if need to enter automatic communication internet status manually, please set value: 255.

Remark: Legend No.15 (capacitor discharge time)

Combination switch type: factory default is 30s (adjusted from 30s to 180s).

Synchronous switch type: factory default is 90s(adjusted from 90s to 180s).

## 11.1 Manual switching test (Must be met : 1. Not over/under voltage 2. Not overheating 3. not voltage phase failure)

three phase compensation:

in manual switching test, Simultaneously press the down button and menu button, and then quickly released, after system enters manual status ("Manual" indicator light illuminates), press "up" button to successively switch on C1, C2 capacitors (if there are two groups), press "down" button to successively switch off C1, C2 capacitors (if there are two groups); switching off and on are performed in order and repeatedly; press "menu" button to return to auto running status. While switching on, use clip-on ammeter to monitor the three-phase current, in normal condition, the currents are almost the same; three phase current is zero when capacitor is completely switched off.

phase-Splitting compensation:

in manual switching test, Simultaneously press the down button and menu button, and then quickly released, after system enters manual status ("Manual" indicator light illuminates), press "up" button to successively switch on Ca, Cb, Cc capacitors, press "down" button to successively switch off Ca, Cb, Cc capacitors; switching off and on are performed in order and repeatedly; press "menu" button to return to auto running status. While switching on, use clip-on ammeter to monitor the three-phase current, in normal condition, the currents are almost the same; three phase current is zero when capacitor is completely switched off.

**Important:** The same one capacitor Manual switch off, once again switch on, You must wait 30 seconds, Internal capacitor voltage drops below 50V, in order to respond. (30 s-180 s can be set).

## 11.2 Simulation switching function

Long press menu button after 3s to loose, running LED indicator changed from green color to two colors (red and green), systems enter simulation switching status. at this time, controller output control signal, switching status indicator of controller changed, not practical switching on or cutting off capacitor. then long press "menu" button again, after 3s to loose, quit simulation switching status, running LED indicator changed into green color

## 12 Parameter factory default setting

Capacitor capacity: set according to factory capacity; take three phase compensation capacitor 20+10Kvar for example, capacity 1 is set as 20, capacity 2 is set as 10;

Lower limit of power factor: 0.96

Switching capacitor delay: 10s

Ratio of current transformer: 100

I grade over voltage protection value: 432VAC (three phase compensation); 240VAC (phase-splitting compensation)

II grade over voltage protection value: 449VAC (three phase compensation); 260VAC (phase-splitting compensation)

Over-temperature protective value: 60°C

Communication address: 255 (255 means that the automatic acquisition)

## 13 Plug-type communication line specification table





4 pcs capacitors to one carton, complimentary 4 pcs D20 type line;

Each 2 cartons capacitors, complimentary 1pc W80 type line;

Each 4 cartons capacitors, complimentary 1pc W260 type line;

Each intelligent controller, complimentary 1 pc D300-W type line

Note: Tolerance  $\pm 2\text{cm}$ , special length line, pls contact us.

line type	length	Image	remark
W20	20cm		each two shunt capacitors connection for
W80	80cm		connection for each two layes capacitors in panel box
W260	260cm		connection for capacitors in main and sub paned box
D300-W	300cm		connection for capacitors and controller

## 14 Analysis of common faults

Fault	Cause	Solution
No display of smart capacitor after power on	<ol style="list-style-type: none"> <li>1.No operating power.</li> <li>2.Cables get loosened in the control board of smart capacitor</li> </ol>	<ol style="list-style-type: none"> <li>1.Check if there is input of voltage to the module; zf MCD swith on</li> <li>2.Open the shell of module and plug in the cable or press tight.</li> </ol>
Abnormal communication occurs after power is on	<ol style="list-style-type: none"> <li>1.Communication line of this module is badly connected or unconnected.</li> <li>2.Loosened terminals and bad contact.</li> <li>3.Short circuit between two communication lines.</li> <li>4.Modules of the same ID number occur in the same system.</li> </ol>	<ol style="list-style-type: none"> <li>1.Connect the communication line and use multimeter to measure if the line is connected or not.</li> <li>2.Fasten the modular terminal.</li> <li>3.Check communication lines and remove the short-circuit trouble.</li> <li>4.Change ID numbers of the same modules to different numbers to ensure the communication is normal.</li> </ol>
Threshold-crossing light illuminates or hinting texts occur after power is on	<ol style="list-style-type: none"> <li>1.Incorrect voltage measuring, over-voltage fault ; phase loss</li> <li>2.Bus voltage is too high or too low.</li> <li>3.Wrong setting of over voltage threshold.</li> <li>4.Wrong setting of over temperature threshold</li> </ol>	<ol style="list-style-type: none"> <li>1.Measure voltage of smart capacitor terminal and remove phase-loss faults.</li> <li>2.Check the bus voltage and try to keep it within the threshold value.</li> <li>3.Reset the over-voltage threshold value.</li> <li>4.Reset the over-temperature threshold value.</li> </ol>
Smart capacitor shows a lead value of power factor when no capacitor is put into operation.	<ol style="list-style-type: none"> <li>1.Wrong phase sequence of voltage or current.</li> <li>2.Electrical load has large harmonic wave.</li> <li>3. When used as slave, fetch the power factor of master.</li> </ol>	<ol style="list-style-type: none"> <li>1.Connect phase sequence of voltage according to the mark on the shell; connect current signal of corresponding phase sequence according to terminal marks; take UA, UB, UC voltage and B phase current only for co-compensation; take UA,UB,UC,UN voltage, IA,IB, IC three phase current for split-compensation; connect to secondary terminals in accordance with phase sequence of voltage.</li> <li>2.Take filtering measures, otherwise capacitor will be damaged.</li> </ol>
The current value displayed on the smart capacitor is not in consistent with existing test current value, i.e. measuring error exists.	<ol style="list-style-type: none"> <li>1.Secondary current transformer is damaged.</li> <li>2.Short-circuit occurs at the output end of secondary current transformer.</li> <li>3.Secondary side of current transformer in the general cabinet is not through the center of secondary current transformer.</li> <li>4.Open-circuit of current transformer in the general cabinet</li> </ol>	<ol style="list-style-type: none"> <li>1.Replace secondary current transformer.</li> <li>2.Check the wiring from secondary current transformer to the module.</li> <li>3.Check the wiring.</li> </ol>

## 15 The meaning of the Warning code

example: three phase compensation display  $Err - 21$  , it means: Large voltage harmonics, over voltage.

Phase-splitting compensation display  $Err - 20$  , it means : Large voltage harmonics (phase A)

Phase-splitting compensation : voltage phase failure it means Voltage imbalance.

$Err - 21$

$Err - 21$

meaning				
CODE	Overcurrent	Large current harmonics	Large voltage harmonics	voltage phase failure
0				
1				✓
2			✓	
3			✓	✓
4		✓		
5		✓		✓
6		✓	✓	
7		✓	✓	✓
8	✓			
9	✓			✓
A	✓		✓	
B	✓		✓	✓
C	✓	✓		
D	✓	✓		✓
E	✓	✓	✓	
F	✓	✓	✓	✓

meaning				
CODE	Under-current	overheating	under voltage	over voltage
0				
1				✓
2			✓	
3				
4		✓		
5		✓		✓
6		✓	✓	
7				
8	✓			
9	✓			✓
A	✓		✓	
B				
C	✓	✓		
D	✓	✓		✓
E	✓	✓	✓	
F				

## HENGYI ELECTRIC GROUP CO.,LTD

ADD: Baitawang Industrial Zone, Beibaixiang County,  
Wenzhou City, Zhejiang Province, China.

TEL:0086-577-6299 0759

FAX:0086-577-6299 0758

Http://www.lastone.cn

E-mail:Lastone@vip.163.com

**LASTONE**

### Product certificate

This product is approved to leave the  
factory after inspection.

Inspectors:

Inspector 02

Production Date:

HENGYI ELECTRIC GROUP CO.,LTD

**LASTONE**

Printed in July 2020