

&

%

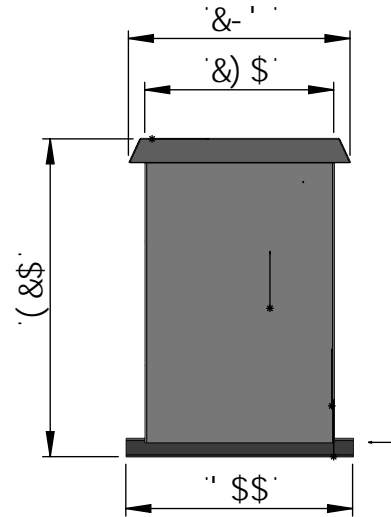
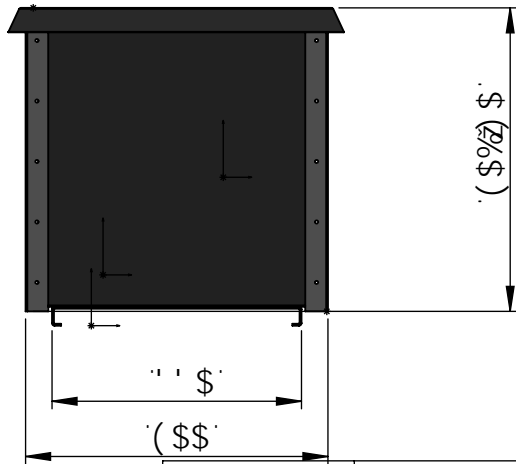
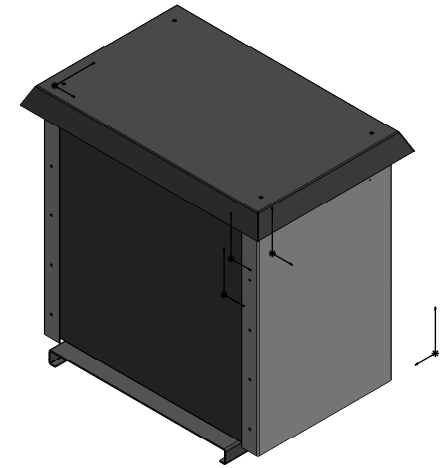
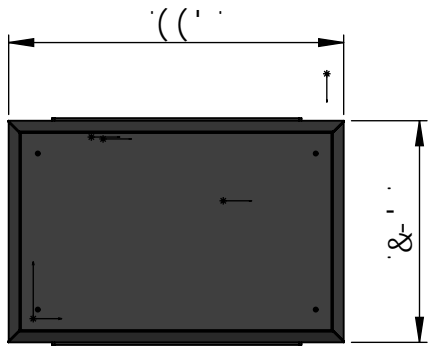

6

6

5

5

DFC DF-95 FM5B87CB: 89BH5@  
 H:9 B: CFA 5HC B 7 CBH5 B98 B H-G  
 8F5K B: "G H:9 GC @DFC D9F HMC:  
 O-B G9FH7 CA D5BMB5A 9 <9F 92" 5BM  
 F9DFC 81 7 HC B B D5FHC F 5G5 K <C @  
 K H: C I H H:9 K F H9B D9FA 6GC B C:  
 O-B G9FH7 CA D5BMB5A 9 <9F 92-G  
 DFC <6H98"

		I B @GG C H: 9FK 69 GD97 ≠ 98.		B5A 9	85H9	07 C A D5BMB5A 92	
		8 A 9B G@BG5F9 B B7 <9G HC @F5B7 9G :F57 HC B5 @± 5B: I @F, A 57 <± "69B8 ± HK C D@57 9897 A 5@ ± H: F99 D@57 9897 A 5@ ±	8F5K B			H H@.	
		B H@F D9H: 9CA 9H 7 HC @F5B7 B: D9F.	7 <97 ?98				
		A 5H@F 5@	9B: "5DDF"				
	B9LH5GGM	I G98 CB	A :: "5DDF"				
			E "5"				
			7 CA A 9BHG			G A9	8K ; "BC "
						F9J	
			C 6I 8C K	558 @	5K ≠ C K	+ ") \$%\$ "	
	5DD@7 5HC B	8C B CHG7 5@8F5K B:				G7 5 @. % % \$	G < 99H % C : %

&

%