



# ADF Power Tuning

THE SHAPE OF POWER TO COME

# ADF P300 Hardware Manual



## Safety notes

Read these instructions carefully and look at the equipment to become familiar with the product before trying to install, operate or maintain it. The following special messages may appear throughout this manual to warn of potential hazards or to call attention to that which clarifies or simplifies a procedure:



**ATTENTION:** Identifies information about practices or circumstances that can lead to personal injury or loss of life, property damage, or economic loss.

## NOTE

Provides additional information to clarify or simplify a procedure.

**ATTENTION:** Only qualified electrical personnel familiar with the construction and operation of this equipment and the hazards involved should install, adjust, operate, or service this equipment. Read and understand this manual and other applicable manuals in their entirety before proceeding. Failure to observe this precaution could result in severe bodily injury or loss of life.

**ATTENTION:** The product contains DC bus capacitors which retain hazardous voltages in excess of 1000 V after input power has been disconnected. After disconnecting input power, wait at least sixty (60) minutes for the DC bus capacitors to discharge and then check the voltage with a voltmeter to ensure the DC bus capacitors are discharged before touching any internal components. Failure to observe this precaution could result in severe bodily injury or loss of life.



**ATTENTION:** This product may have been modified from factory in order for the auxiliary power to be supplied externally. After disconnecting main fuses, the external auxiliary power must also be disconnected.

**ATTENTION:** Before manipulating current transformers, make sure that the secondary is short-circuited. Never open the secondary of a loaded current transformer. You must always wear isolating gloves and eye-protection when working on electrical installations. Also make sure that all local safety regulations are fulfilled.

**ATTENTION:** Only qualified personnel or other trained personnel who understand the potential hazards involved may make service, updates, troubleshooting, repair or similar work to the product. Any such activities not made correctly may result in uncontrolled operation. Failure to observe this precaution could result in damage to equipment and bodily injury. Although reasonable care has been taken to provide accurate and authoritative information in this document, no responsibility is assumed by **Comsys** for any consequences arising out of the use of this material.

The information in this document is subject to change without notice.

© 2008 – 2016 Comsys AB. All rights reserved.

## Product identification

The product identification label is found inside the door of the cabinet. Remember to check that your supply is compatible with the technical data stated on the label before installing and commissioning the Active Filter.

### Active Filter ADF P300

**Technical data:**  
 Line voltage: 208 - 480 V  
 Frequency: 50/60 Hz  
 Current capacity: 120 A  
 Protection class: IP20  
 Cooling medium: Air  
 Ambient temperature: 0 - 40°C

**Product identification:**  
 Model: ADF P300-120/480  
 Art. No.: 400 089  
**Serial number:**



**Comsys AB**  
[www.comsys.se](http://www.comsys.se)  
 Made in Sweden

### Active Filter ADF P300 UL

**Technical data:**  
 Line voltage: 208 - 480 V  
 Frequency: 50/60 Hz  
 Current capacity: 110 A  
 Protection class: NEMA 1  
 Cooling medium: Air  
 Ambient temperature: 0 - 40°C

**Product identification:**  
 Model: ADF P300-110/480-UL  
 Art. No.: 400 083  
**Serial number:**



**Comsys AB**  
[www.comsys.se](http://www.comsys.se)  
 Made in Sweden

This manual applies to products listed in the table below:

Table 1: Applicable ADF P300 models

Product line	Models	Current rating	Voltage
ADF P300 Air cooled, 3 wire	ADF P300-120/480	120 A <sub>RMS</sub>	208 – 480 V
	ADF P300-240/480	240 A <sub>RMS</sub>	
	ADF P300-360/480	360 A <sub>RMS</sub>	
	ADF P300-90/690	90 A <sub>RMS</sub>	480 – 690 V
	ADF P300-180/690	180 A <sub>RMS</sub>	
	ADF P300-270/690	270 A <sub>RMS</sub>	
ADF P300 UL/cUL version Air cooled, 3 wire	ADF P300-110/480-UL	110 A <sub>RMS</sub>	208 – 480 V
	ADF P300-220/480-UL	220 A <sub>RMS</sub>	
	ADF P300-330/480-UL	330 A <sub>RMS</sub>	
	ADF P300-90/600-UL	90 A <sub>RMS</sub>	480 – 690 V
	ADF P300-180/600-UL	180 A <sub>RMS</sub>	
	ADF P300-270/600-UL	270 A <sub>RMS</sub>	

## Standards

This product is CE compliant, which implies that is in conformity with the European Community low voltage directives 72/23/EEC and 93/68/EEC and it bears the CE label.

The following standards apply:

Table 2: Standards

Standards	
Electromagnetic compatibility	EN 61000-6-2, EN 61000-6-4
Electrical design and safety	EN 50178 / VDE0160
Protection class	IP21 according to IEC 529 (ADF P300) NEMA1 according to NEMA 250 (ADF P300-UL)
Approval marking	72/23/EEC, 93/68/EEC CE-mark

## UL/cUL version Standards

The UL/cUL versions, art no 400 083, 400 084, 400 085, 400 086, 400 087, 400 088 are approved according to UL/CSA standards.

Table 3: UL/cUL Standards

Standards	
Electrical design and safety	UL508/CSA22.2

File no NMTR.E357863.

## Document revision

Table 4: Document revision

Revision	Date	History:	Status:
A	2008-02-19	ORIGINAL	RELEASED
A2	2008-08-10	REVISED FOR SCC2 CONTROL	RELEASED
A3	2009-11-25	REVISED FOR RELEASE 1.0	RELEASED
C1	2010-02-08	REVISED FOR RELEASE 1.1	RELEASED
C2	2010-06-04	REVISED UPDATED NAMING	RELEASED
C4	2010-09-30	MINOR REVISION	RELEASED
D05	2011-12-20	MAJOR UPDATE	RELEASED
D07		SPLIT BETWEEN HARDWARE AND USERS MANUAL	RELEASED
D08	2012-03-16	ADDED P300N	RELEASED
D09	2012-06-04	MINOR CORRECTIONS	RELEASED
D10	2014-01-17	MINOR CORRECTIONS	RELEASED
D11	2014-06-17	MAJOR CORRECTIONS; UL/cUL UPDATE	FOR REVIEW
D12	2014-07-29	MINOR CORRECTIONS	RELEASED
D13	2015-11-04	MINOR CORRECTIONS; UPDATE X11/X12 TERMINALS	RELEASED
REV15	2016-03-10	MINOR CORRECTIONS; REMOVAL OF EOL PRODUCTS ADF P300W and ADF P300N	RELEASED

# Contents

- Safety notes ..... 3**
- Product identification..... 4**
- Standards ..... 5**
- UL/cUL version Standards..... 5**
- Document revision ..... 5**
- Contents ..... 6**
- List of figures ..... 9**
- List of tables..... 10**
- 1 Overview ..... 11**
  - 1.1 Content ..... 11
  - 1.2 Organization of manual..... 11
  - 1.3 Related documentation..... 11
- 2 Active Filter Overview ..... 12**
  - 2.1 Introduction to the Technology..... 12**
    - 2.1.1 The Problem: Poor Power Quality ..... 12
    - 2.1.2 The Solution: Active Filters ..... 12
    - 2.1.3 Common applications which can benefit from Active Filters ..... 12
    - 2.1.4 How Active Filters Work..... 12
  - 2.2 System Overview ..... 13**
    - 2.2.1 Features ..... 13
    - 2.2.2 Main components overview ..... 14
      - 2.2.2.1 User interface (HMI-3 Extended) ..... 14
      - 2.2.2.2 Power Indicator Button (PIB)..... 14
      - 2.2.2.3 Control computer (SCC2)..... 15
      - 2.2.2.4 Automation circuit board (ACB)..... 15
      - 2.2.2.5 Auxiliary voltage transformer (T1) ..... 15
      - 2.2.2.6 Auxiliary voltage supply Unit (PSU) ..... 15
      - 2.2.2.7 Auxiliary fuse block (F1)..... 15
      - 2.2.2.8 Power processor units (PP1...PP3) ..... 16
      - 2.2.2.9 Power processor fuse block (Q1...Q3) ..... 16
      - 2.2.2.10 Power connection terminals (X10) ..... 16
      - 2.2.2.11 User signal interface and CT terminals (X11, X12)..... 16
      - 2.2.2.12 Multi-master connection (X22 & X23; optional)..... 16
  - 2.3 Filter Configuration ..... 16
- 3 Getting started..... 19**
  - 3.1 Receiving and unpacking ..... 19
  - 3.2 Installation..... 19
  - 3.3 Configuration and Commissioning..... 19
- 4 Installation ..... 20**

- 4.1 Unpacking the Active Filter ..... 20**
  - 4.1.1 Before unpacking and Installation/Commissioning ..... 20
  - 4.1.2 Lifting the Active Filter..... 21
  - 4.1.3 Preservation of the Active Filter ..... 21
  - 4.1.4 Startup preparations ..... 21
  - 4.1.5 Storage conditions ..... 22
  - 4.1.6 Transport conditions ..... 23
- 4.2 Environmental conditions ..... 23**
  - 4.2.1 Operating conditions ..... 23
  - 4.2.2 Physical conditions ..... 23
  - 4.2.3 Cooling air flow requirements ..... 23
- 4.3 Connection of the Active Filter ..... 24**
  - 4.3.1 Prior to any connection ..... 24
    - 4.3.1.1 Prior to any connection ADF P300..... 24
  - 4.3.2 Power connection terminals (X10)..... 25
    - 4.3.2.1 Selection of power cable size – CE systems ..... 25
    - 4.3.2.2 Selection of power cable size - UL/cUL systems ..... 25
    - 4.3.2.3 Surge Protection (UL/cUL versions only)..... 26
    - 4.3.2.4 Branch protection (UL/cUL versions only)..... 26
    - 4.3.2.5 Main fuse selection..... 26
    - 4.3.2.6 Auxiliary fuse selection..... 26
  - 4.3.3 Protective earth (PE) connection ..... 26
    - 4.3.3.1 Protective earth in UL/cUL systems ..... 27
- 4.4 Auxiliary Transformer Setup ..... 27**
- 4.5 User signal interface and CT terminals (X11, X12)..... 28**
  - 4.5.1 Current transformer connection ..... 28
    - 4.5.1.1 Selection of current transformers ..... 29
    - 4.5.1.2 Recommended current transformer cable size ..... 29
    - 4.5.1.3 Location of current transformers ..... 30
    - 4.5.1.4 Connection and wiring of current transformers ..... 31
    - 4.5.1.5 Connection of current transformers with paralleled systems ..... 31
    - 4.5.1.6 Use of summation transformers ..... 32
  - 4.5.2 Multi-master bus (X22 & X23; optional) ..... 32
- 5 Maintenance ..... 33**
  - 5.1 Biannual inspection ..... 33**
    - 5.1.1 Visual inspection ..... 33
    - 5.1.2 Cleaning ..... 33
    - 5.1.3 Fuses ..... 34
    - 5.1.4 Cooling system ..... 34
    - 5.1.5 Door, lock inspection..... 34
    - 5.1.6 Air filter ..... 34

5.1.7 Electrical connection ..... 34

**Appendix A Technical Specifications .....35**

    A.1 Technical Data – ADF P300-XXX/480 ..... 35

    A.1 Technical Data – ADF P300-XXX/480 – UL/cUL version..... 36

    A.2 Technical Data – ADF P300-XXX/690 ..... 37

    A.2 Technical Data – ADF P300-XXX/600 – UL/cUL version..... 38

**Appendix B Compatibility with passive compensation .....39**

**Appendix C Harmonics derating.....40**

    C.1 Single harmonic maximum current..... 40

    C.2 Determining the thermal limit ..... 41

    C.3 Summary ..... 41

**Appendix D Altitude derating.....42**

    D.1 Air cooling derating ..... 42



## List of figures

Figure 1: Basic operating principle .....	13
Figure 2: Uncompensated load current (left), Compensation current (middle), Compensated net current (right) .....	13
Figure 3: ADF P300 cabinet overview.....	14
Figure 4: ADF P300 main components .....	14
Figure 5: SCC2 control computer front panel indicators location .....	15
Figure 6: Correct lifting the Active Filter .....	21
Figure 7: Active Filter with raised roof.....	22
Figure 8: ADF P300, Active Filter power (X10) and user (X11/X12) connectors, Conduit Entry.....	24
Figure 9 X11 and X12 Terminal block, CT shortened in this figure. As well as Multi-Master interface X22 and X23.....	29
Figure 10: Current Transformer placement diagram – closed loop .....	30
Figure 11: Current Transformer placement diagram – open loop.....	30
Figure 12: No current transformer in sensor-less control.....	30
Figure 13: Current Transformer connection diagram – closed loop .....	31
Figure 14: Current Transformer connection diagram – paralleled units .....	32
Figure 15: Example setup for Multi-Master operation .....	32
Figure 16: Connection of an Active Filter unit, passive compensation, and location of CTs. ....	39

## List of tables

Table 1: Applicable ADF P300 models .....	4
Table 2: Standards.....	5
Table 3: UL/cUL Standards.....	5
Table 4: Document revision .....	5
Table 5: PIB color coding .....	15
Table 6: SCC2 control computer front panel LED indicators .....	15
Table 7: Maximum storage conditions .....	22
Table 8: Long-term storage conditions.....	22
Table 9: Maximum transport conditions .....	23
Table 10: Maximum operating environmental conditions.....	23
Table 11: Minimum air flow requirements .....	23
Table 12: Recommended cable sizes .....	25
Table 13 Auxiliary fuse selection.....	26
Table 14: Auxiliary standard voltages .....	27
Table 15: Voltage range 208 – 415 V .....	27
Table 16: Voltage range 380 – 480 V .....	27
Table 17: Voltage range 480 – 600 V .....	27
Table 18: External interface terminals X11 / X12.....	28
Table 19: Current transformer (CT) specification.....	29
Table 20: Burden as function of cable size and length .....	29
Table 21 ADF CT connection data.....	30
Table 22: CT connection table .....	31
Table 23: Technical specifications ADF P300-XXX/480 .....	35
Table 24: Technical specifications ADF P300-XXX/480 .....	36
Table 25: Technical specifications ADF P300-XXX/690 .....	37
Table 26: Technical specifications ADF P300-XXX/600.....	38
Table 27: Maximum current output on single harmonics .....	40

# 1 Overview

## 1.1 Content

This manual describes the hardware, installation and maintenance topics of the Comsys ADF P300 series of active filters.

## 1.2 Organization of manual

The ADF P300 manual is organized in two parts, namely:

1. ADF P300 Hardware Manual, doc no 1 199 171 (this document)
2. ADF P100/P300 User Manual, doc no 1 199 172

The Hardware Manual covers hardware related issues, such as installation, cable selection, CT configuration, preventive maintenance, and troubleshooting.

The user manual covers issues which are governed by the installed software in the system such as operation, initial configuration and commissioning. Hence, when the system is updated, a new User Manual is supplied.

## 1.3 Related documentation

- ADF P100/P300 User Manual (doc no 1 199 172)

## 2 Active Filter Overview

### 2.1 Introduction to the Technology

Comsys offers a new generation of high performance power quality products for industrial applications based on active filter technology, which removes the losses and restores the natural wave shape of the current.

#### 2.1.1 The Problem: Poor Power Quality

Transients, harmonics, voltage variations (including flicker) and unbalance puts the power grid, machines, motors and computer equipment under considerable stress resulting in disturbances, production stops, waste of energy and decreased lifetime. These terms, among others, constitute power quality.

A large part of the equipment connected to the power grid creates disturbances, voltage variations and undesired harmonics that pollute the grid. This pollution generates losses, disturbances, production stops and reduces expected lifetime of cabling, transformers and machines as a cause of the excess load.

This leads to decreased capacity in the electrical network, less effective electrical power consumption and energy losses that transforms into both technical and economic costs.

#### 2.1.2 The Solution: Active Filters

Traditionally fixed, electro-mechanical and semiconductor controlled filters and/or compensators have been used to limit or minimize power quality problems in the network.

They operate mainly on a fixed or stepped basis using passive elements. All these solutions suffer from the same drawbacks – they add losses, are installation specific and have no ability to adapt to or follow dynamic load changes.

The Active Dynamic Filter (ADF) eliminates loss creating behaviors such as harmonics, flicker, voltage variations, resonances and reactive energy using a highly dynamic, step less digitally controlled compensation and filtering approach. By continuously monitoring the network and injecting exactly the right amount of compensation current – at exactly the right time – the most efficient and accurate solution to any power quality problem can be achieved.

This approach enables the current waveform to be restored instantaneously, the current consumption to be lowered and changes in load or installation conditions to be fully compensated at all times.

#### 2.1.3 Common applications which can benefit from Active Filters

- Harmonic/reactive power suppression in 3-phase systems
- Industrial production machines (e.g. mills, presses)
- Variable speed drive systems (AC drives, DC drives)
- Electrical welding systems
- Plastic machinery (extruders, injection molders, film treatment machines)
- Power generation systems and UPS equipment
- Electrolytic processes
- Induction heating

#### 2.1.4 How Active Filters Work

An active filter is basically a very advanced computer controlled current generator with the ability to produce any shape or form of current with little or no delay.

A simplified diagram of the operating principle is shown in Figure 1. The system is connected in parallel with the load requiring compensation.

Currents and voltage delivered from the network are measured and analyzed [3], to determine if disturbances such as e.g. reactive displacement and/or harmonics are present.

The system injects compensation currents [2] which is the exact opposite of the e.g. harmonics and/or reactive displacement to cancel out the undesired behavior of the load [1].

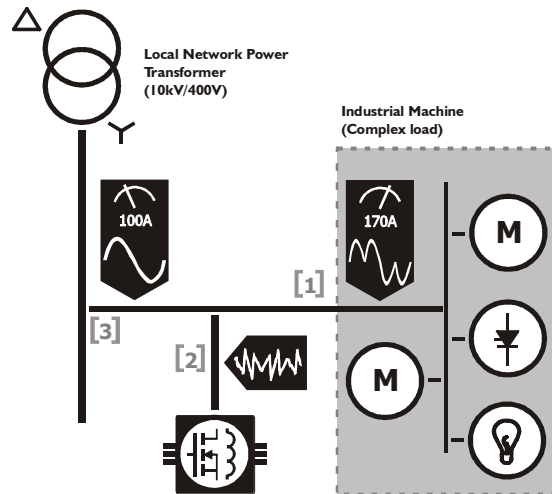

Figure 1: Basic operating principle

The Figure 2 shows how the current consumed by an electrical load may look like prior to and during compensation. Before compensation, the current consists of several harmonics in addition to the fundamental, which are apparent from the current's deformed waveform. After injection of the compensation current, the load current's natural sinusoidal waveform is restored and the loss creating behaviors have been eliminated.

The function of the power transmission system is restored, which leads to saved energy, lower disturbances or in short – improved power quality and significantly lowered costs in electrical installations.

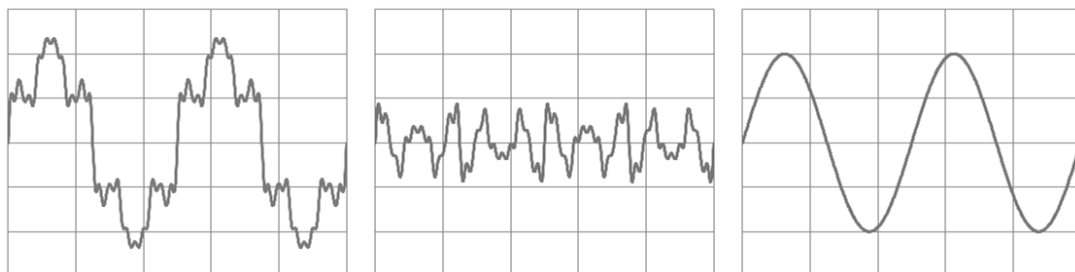

Figure 2: Uncompensated load current (left), Compensation current (middle), Compensated net current (right)

## 2.2 System Overview

The Active Filter ADF P300 is a series of modular high power active power filters available in the power range from 90 A up to 360 A of compensation power per cabinet. The ADF Active Filter products are delivered in industry standard cabinet system cabinets.

### 2.2.1 Features

General features:

- Compact design in standard floor standing enclosure cabinet
- High performance and reliability
- Advanced digital control and low response time
- Several units can be operated in parallel for higher power ratings
- Non-overloadable and insensitive to changes in network or load conditions
- Main fuse block included and high short circuit capacity
- Easy installation, commissioning and maintenance

## 2.2.2 Main components overview

This section describes the major components of the Active Filter. Each unit is enclosed in one cabinet holding all necessary functions and modules.

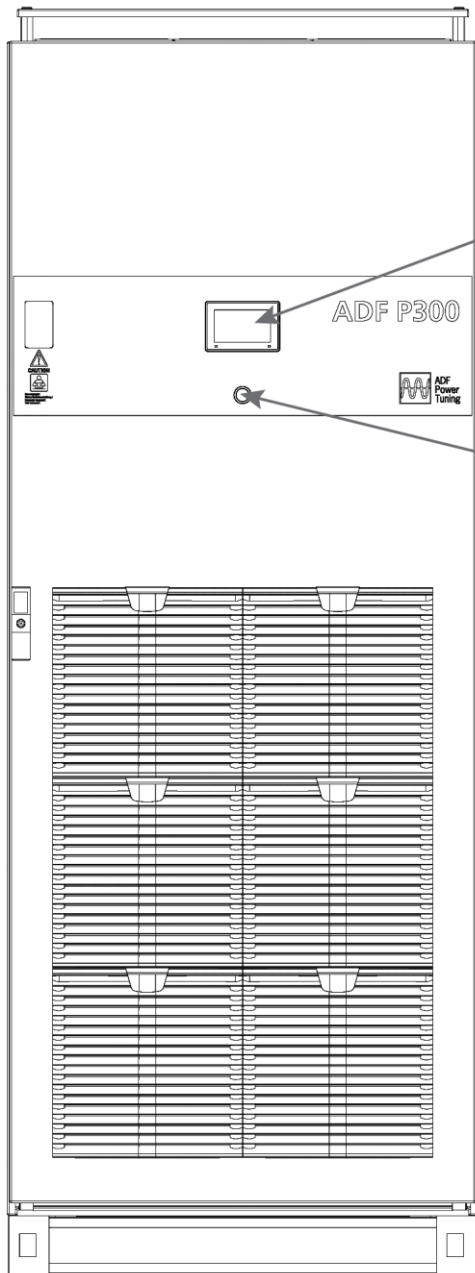

Figure 3: ADF P300 cabinet overview

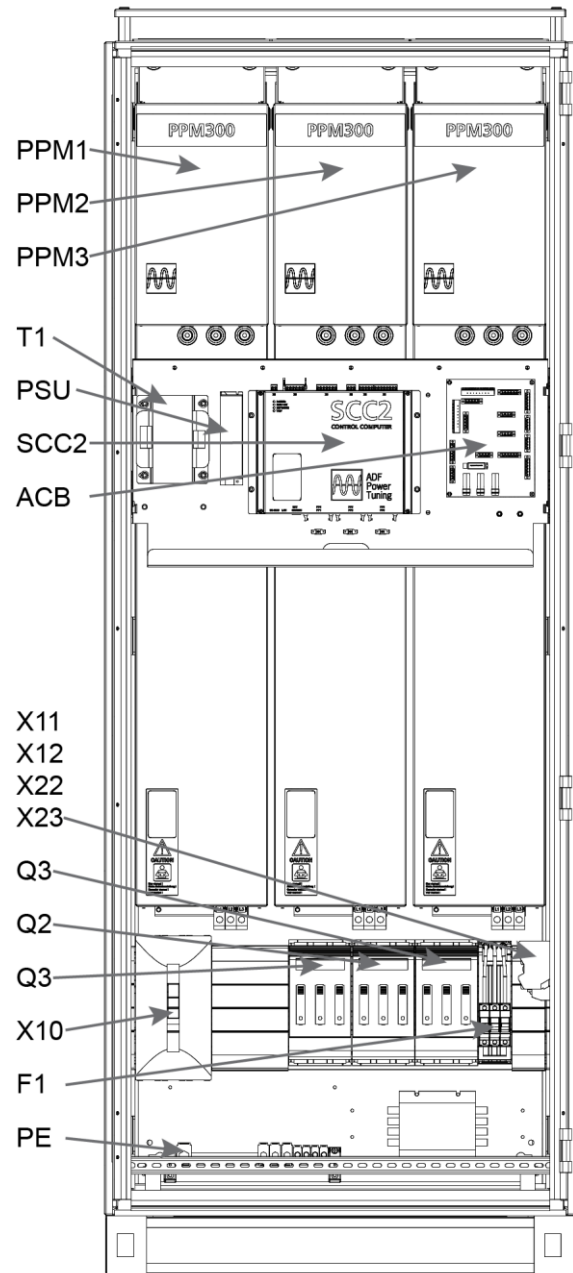

Figure 4: ADF P300 main components

### 2.2.2.1 User interface (HMI-3 Extended)

All settings, configuration and operation can be performed from the HMI (Human- Machine Interface) panel, see Figure 3. Please refer to the ADF P100/P300 User Manual (1 199 172) on how to use the HMI.

### 2.2.2.2 Power Indicator Button (PIB)

Basic operations like start and stop, can be performed on the PIB. The button also shows basic information on an Indicator light, internal in the button.

The ADF is powered ON by pressing this button short, and powered OFF by pressing the PIB for two seconds.

Table 5: PIB color coding

Color	Description	Button action
Fading red	System in trip and log is being written to SD-card	None
Solid red	System in trip	Acknowledge all alarms
Fading yellow	Pre-charge / all other states	None
Solid yellow	System in stopped	Start system
Fading green	System is in standby	Stop system
Solid green	System is running	Stop system
None	System is powered off	Boot system

### 2.2.2.3 Control computer (SCC2)

The SCC2 control computer is a stand-alone digital processing system containing all functions for controlling the power processor modules. It also features protection circuitry for monitoring and main contactor control. Indicators on the front panel display operational modes and status as well as power as shown in Table 6.

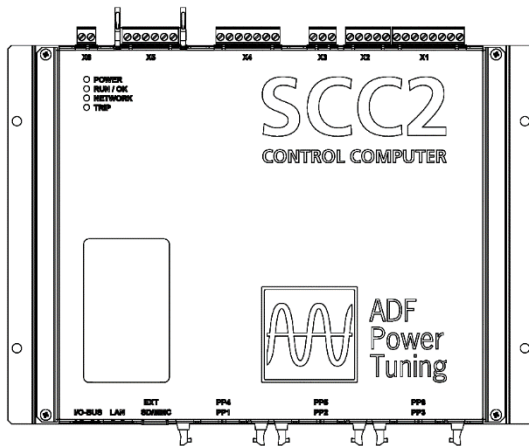

Figure 5: SCC2 control computer front panel indicators location

Table 6: SCC2 control computer front panel LED indicators

Description	Color	Description
POWER	Blue	Indicates that the control computer has power.
RUN/OK	Red/ Green/ Yellow	Active Filter operational status: <b>Green blink</b> = System is running. <b>Yellow blink</b> = System is stopped. <b>Red/yellow blink</b> = System is tripped / an alarm is active. <b>Steady yellow</b> = System is in Setup mode. <b>Fast red blink</b> = SCC2 boot-up failure.
NETWORK	Yellow	LAN network activity (if connected)
TRIP	Red	SCC2 hardware trip. If lit the control computer is malfunctioning.

An RJ45 connector is placed at the bottom of the SCC2. A “FTP category 5” or better Network cable can be used to connect to the ADF.

### 2.2.2.4 Automation circuit board (ACB)

The Automation Circuit Board (ACB) routes all signal and auxiliary circuit inside the ADF.

### 2.2.2.5 Auxiliary voltage transformer (T1)

The auxiliary voltage transformer (T1) transforms mains voltage to 230 V<sub>AC</sub>.

### 2.2.2.6 Auxiliary voltage supply Unit (PSU)

The auxiliary voltage supply (PSU) transforms 230 V<sub>AC</sub> to 24 V<sub>DC</sub>.

### 2.2.2.7 Auxiliary fuse block (F1)

The auxiliary fuse block (F1) protects voltage measurement circuits, pre charging circuits and auxiliary power systems inside the Active Filter.

### 2.2.2.8 Power processor units (PP1...PP3)

Every Active Filter is equipped with one or more power processing modules (PPs) which are the power electronic converters that actually generate the compensation currents. Power processors work in parallel in a modular approach to achieve higher power output and compensation currents. Each power processor contains power electronics such as IGBT modules and driver electronics, EMC-filter, DC-storage, cooling fans and line filtering components.

### 2.2.2.9 Power processor fuse block (Q1...Q3)

The Power Processor fuse block (Q1...Q3) provides protection for the system in the event of hardware failure. Each power processor has its own individual fuse block allowing quick disconnection of a failed power processor. Note that there is only one fuse block installed per module installed.

### 2.2.2.10 Power connection terminals (X10)

Used for connection of mains to the system. See section 4.3.2 for detailed connection information. The terminals are placed in the lower part of the cabinet.

As a standard, one connection terminal is installed. If required a second terminal can be ordered with the article number 100 430.

### 2.2.2.11 User signal interface and CT terminals (X11, X12)

The user signal interface terminals, X11 are used for connecting current transformers, interface to external devices via alarm outputs and digital inputs and for interconnecting the systems for parallel operation. See section 4.3.3.1 for more information on how to connect current transformers (CTs), digital inputs and outputs.

### 2.2.2.12 Multi-master connection (X22 & X23; optional)

When paralleling ADF P300 systems in closed loop configuration, the multi-master interface is used for synchronization purposes.

## 2.3 Filter Configuration

The ADF P300 filter comes in a variety of configurations. The product configuration is defined by the product string. The product string consists of the basic type of product, such as ADF P300-120/480, but also a list of factory built-in options.

<b>NOTE</b>	As of the release of the 2016 price list, products are no longer defined by their article number, but by their product string. Article numbers are present internally at Comsys, but these are subject to change at any time.
-------------	---

Please note that other options exist that are not immediately part of the product string, such as software licenses that do not have a hardware impact. The nomenclature of the product string is defined as below:

ADF PmodQ-cur/vol{-UL}\_{OPTION STRING: ABCDEFGHIJ}

ADF P300-120/480{-UL}\_ABCDEFGHIJ

ADF P300-120/480\_T-E-----21

All positions are always visible within the product string, except for 'Q' that is a qualifier that enables a certain type of product. In the ADF P300 line, the only available qualifier is 'W' for the ADF P300W product which means the product is liquid cooled. The ADF P300W will be relaunched in a new version during 2016.

Except for the qualifier, all options are "visible" in the string at all times. When an option is enabled, it is lit up in the string. For example, the multi master option is on position B in the string



ABCDEFGHIJ above, and is indicated by letter 'C' so it can immediately be seen if multi-master is enabled by looking below:

ADF P300-120/480\_TCE----21

A similar system *without* multi-master looks like the following:

ADF P300-120/480\_T-E----21

Also not that the encapsulation class (ingress protection) is documented in the last two letter. 21 in this case means IP21. All relevant ADF P300 article strings are listed in the table below.

Position	ADF	Active Dynamic Filter
<b>Product Type (mod) and Qualifier (Q)</b>		
<b>ADF P300Q</b> <small>ADF P300(W)-120/480-UL_T-E-----21</small>	<b>P300</b>	3phase-3wire, air cooled, Standalone Active Dynamic Filter
	<b>P300W</b>	3phase-3wire, liquid cooled, Standalone Active Dynamic Filter (currently not available)
<b>Current Rating (cur)</b>		
<b>cur</b> <small>ADF P300(W)-120/480-UL_T-E-----21</small>	<b>120, 240, 360</b>	120/240/360 A rating on ADF P300 in particular 415/480 V versions (IEC)
	<b>110, 220, 330</b>	110/220/330 A rating on ADF P300 in particular 415/480 V versions (UL)
	<b>90, 180, 270</b>	90/180/270 A rating on ADF P300 in particular 600/690 V versions (IEC and UL)
<b>Voltage Level (vol)</b>		
<b>vol</b> <small>ADF P300(W)-120/480-UL_T-E-----21</small>	<b>415</b>	Permissible voltage levels are: 215/230/245/385/400/415 V
	<b>480</b>	Permissible voltage levels are: 380/400/420/440/460/480 V
	<b>600</b>	Permissible voltage levels are: 475/500/525/550/575/600 V
	<b>690</b>	Permissible voltage level is: 690 V
<b>Certification (-UL)</b>		
<b>-UL</b> <small>ADF P300(W)-120/480-UL_T-E-----21</small>	<b>-UL</b>	If present in the model string, UL/cUL approval is present. If not present, IEC/CE approval.
<b>Options (ABCDEFGH)</b>		
<b>Grounding System (A)</b>		
<b>A</b> <small>ADF P300(W)-120/480-UL_T-E-----21</small>	<b>T</b>	TN/TT grounding system (standard if not otherwise specified)
	<b>I</b>	IT grounding system
<b>Multi Master (B)</b>		
<b>B</b> <small>ADF P300(W)-120/480-UL_T-E-----21</small>	<b>C</b>	Multi Master option included
<b>HMI (C)</b>		
<b>C</b> <small>ADF P300(W)-120/480-UL_T-E-----21</small>	<b>B</b>	Basic HMI with PIB only
	<b>E</b>	Extended HMI with PIB and 4.3" color touchscreen interface (standard on ADF P300)
	<b>2</b>	Legacy Alphanumeric HMI-2 (standard on UL systems)
<b>Reserved (unused) option codes (DEFGH)</b>		
<b>DEFGH</b> <small>ADF P300(W)-120/480-UL_T-E-----21</small>	-	Currently not in use
<b>Protection class (IJ)</b>		
<b>IJ</b> <small>ADF P300(W)-120/480-UL_T-E-----21</small>	<b>21</b>	IP21 (IEC/CE systems only)
	<b>43</b>	IP43 (not yet available) (IEC/CE systems only)
	<b>54</b>	IP54 (not yet available) (IEC/CE systems only)
	<b>N1</b>	NEMA1 (UL/cUL systems only)
	<b>N3</b>	NEMA3R (not yet available) (UL/cUL systems only)

## 3 Getting started

This section is intended to help you get through to operate the Active Filter with the least work on your part. Guidance and hints are provided. First it is important that you read and observe the safety notes in the beginning of this manual to help avoid damage to equipment, installation and persons.

### 3.1 Receiving and unpacking

On receiving the unit read notes in section 4.1 “Unpacking the Active Filter”. If the system is to be transported on site, please be sure to avoid excessive strains. In particular, no components must be bent or isolating distances altered in the course of transportation or handling. No contact must be made with electronic components and contacts. Also note that all operations serving transport, installation and commissioning as well as maintenance must to be carried out by skilled technical personnel.

Active Filters contain electrostatic sensitive components which are liable to damage through improper use. Electric components must not be mechanically damaged or destroyed (potential health risks).

### 3.2 Installation

It is important to prepare the installation site prior to installing and connecting the Active Filter. In the section 4 “Installation”, important issues such as location of terminals, cable size recommendations and cooling air flow requirements are discussed. To maintain operation and long equipment life it is vital to keep environmental conditions in accordance with the specifications.

Current transformer (CT) selection is important for good performance. Read about CT selection and connection in section 4.5.1 “Current transformer connection” and if possible use separate CTs not shared with other equipment e.g. power quality meters.

Notice that an operation without current transformer is also possible. “Sensor-less Control” is an optional operation mode.

Good earth connection is also important to achieve best results and electrical safety as described in the section 4.3.3 “Protective earth (PE) connection”.

It is important that any materials or method for connection used is within limits with respects to local safety regulations. Also that appropriate fuses are fitted in the mains connection.

### 3.3 Configuration and Commissioning

The Active Filter has extensive functionality built-in for several modes of operation.

The ADF P100/P300 User Manual (1 199 172) details how to configure the software parameters for the ADF P300.

## 4 Installation

### 4.1 Unpacking the Active Filter

Each Active Filter is delivered in packaging suitable for transportation. Upon reception of the Active Filter, visually inspect that the packaging is in good condition. Verify that all items are present in the package:

- This manual (1 199 171)
- The ADF P100/P300 User Manual (1 199 172)
- Bag with distances, screws and cabinet key
- Top roof



**ATTENTION:** Before unpacking and installation the Active Filter please read through the following pages THOROUGHLY to make sure that it's handled in the right way.

The unit is heavy and weighs several hundred kilograms.

Do not attempt to move the unit before reading the lifting instruction and acting accordingly.

Attempt to move the equipment without proper equipment and not according to instructions may result in damage of the equipment and injury.

#### 4.1.1 Before unpacking and Installation/Commissioning

Before moving the Active Filter without its protective packaging please pay extra attention to the section in this document that handles lifting.



**ATTENTION:** Make sure the cabinet is closed at all time, even when installing it since it contains very sensitive power electronics.

### 4.1.2 Lifting the Active Filter

If the Active Filter is to be moved when not in its protective packaging, please do it according to this document. Always handle the Active Filter with care since it consists of sensitive power electronics.

The Active Filter may only be lifted in the lifting lugs on top of the Active Filter. Also the angle between the lifting wire and the top of the Active Filter must be minimum 60 degrees according to Figure 6. Please note that roof should not be raised until commissioning and start-up of the system.

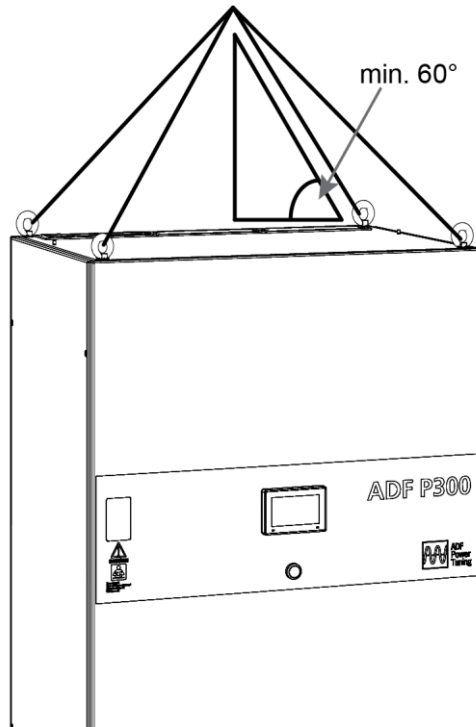

Figure 6: Correct lifting the Active Filter

If moving the Active Filter with for example a fork lift, it may only be moved on its back or standing up, not on its sides.

### 4.1.3 Preservation of the Active Filter

After the Active Filter has been placed in its intended physical position, following steps has to be followed:

- Always keep the door closed on the cabinet, this to keep out dust and other particles that may harm the system.
- Cover up the air-outlet on the top of the filter

### 4.1.4 Startup preparations

Follow the following instructions before attempting start-up of the filter:

#### Raise the roof:

- Loosen the four lifting lugs
- Install the supplied standoff screws in each corner on top of the cabinet and place the outer roof on top of them.
- Install the supplied M6 screws through a plastic washer in each corner to secure the outer roof in place.
- Finally install the protective plastic cap on top of each screw.

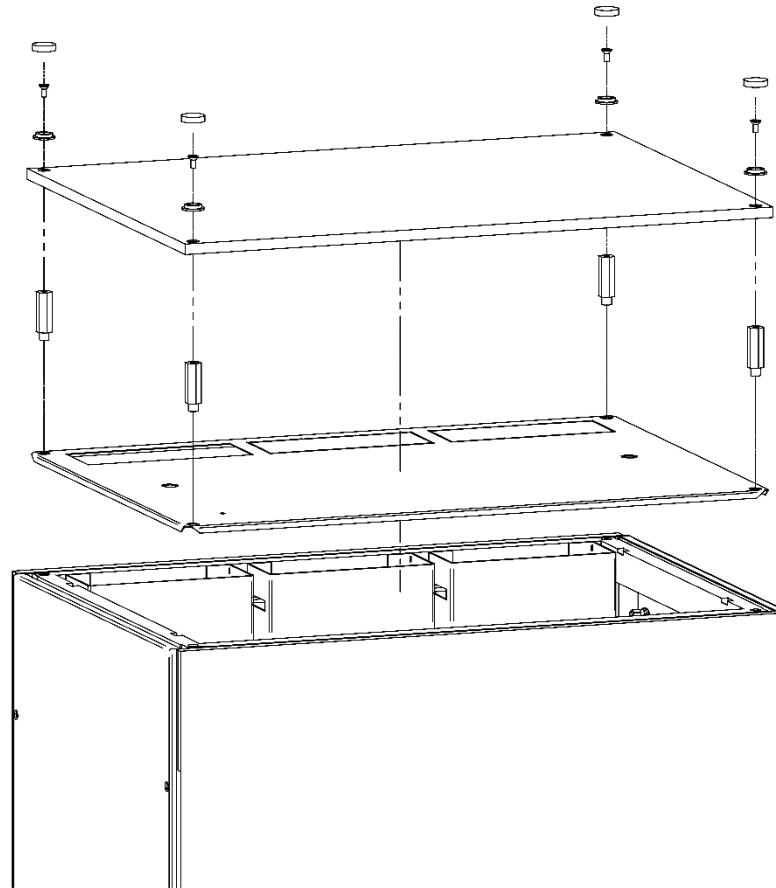

Figure 7: Active Filter with raised roof

**ATTENTION:** A blocked power module air channel will lead to insufficient cooling and can cause damage to the system. Ensure that the air channels are unobstructed before starting the system.

**ATTENTION:** The system must be fixed to the floor, or the top of the system must be fixed to a wall similar solid object. The system is top heavy.

### 4.1.5 Storage conditions

During storage of the unit, the unit should be kept within the following conditions. The conditions are acceptable only when the unit is kept in its shipping packaging.

Table 7: Maximum storage conditions

Maximum storage conditions (in protective shipment package)	
Temperature	-25 °C to 70 °C (-13 °F to 158 °F)
Relative humidity	Less than 95 %, non-condensing
Environmental conditions	Chemical class 3C3 Mechanical class 3S3

Table 8: Long-term storage conditions

Maximum storage conditions (in protective shipment package)	
Temperature	-25 °C to 35 °C (-13 °F to 158 °F)
Relative humidity	Less than 75 %, non-condensing
Environmental conditions	Chemical class 3C3 Mechanical class 3S3

### 4.1.6 Transport conditions

During transport of the unit, the unit should be kept within the following conditions. The conditions are acceptable only when the unit is kept in its shipping packaging.

Table 9: Maximum transport conditions

Maximum transport conditions (in protective shipment package)	
Temperature	-25 °C to 70 °C (-13 °F to 158 °F)
Relative humidity	Less than 95 %, non-condensing
Environmental conditions	Chemical class 3C3 Mechanical class 3S3

## 4.2 Environmental conditions

### 4.2.1 Operating conditions

The unit is suitable for indoor operation only. If the unit is operated within the below limits, full power may be utilized. During more demanding conditions, the unit will be derated when approaching full power.

The unit must be placed in a well-ventilated area. For cooling requirements, see section 4.2.3 “Cooling air flow requirements” below.

Table 10: Maximum operating environmental conditions

Maximum operating environmental conditions	
Temperature	0 °C to 50 °C, up to 40 °C without derating 32 °F to 122 °F, up to 104 °F without derating
Relative humidity	Less than 95 %, non-condensing
Altitude	1000 m (3300 ft) Derating may be required at higher altitude.
Environmental conditions	Chemical class 3C3 Mechanical class 3S3



**ATTENTION:** In case of an air-cooled unit, make sure that the unit is installed in an environment without conductive or corrosive dust. If conductive or corrosive dust is present extra precautions must be taken. Contact your Comsys representative.

### 4.2.2 Physical conditions

The Active Filter should be placed with at least 50 mm / 2” clearance to the wall behind it. There should be a minimum of 500 mm / 20” clearance to the ceiling above the roof of the unit.

In front of the door, there should be a minimum clearance of 800 mm / 32” to allow the door to fully open.

In general, local regulations may impose stricter demands.

### 4.2.3 Cooling air flow requirements

The cooling air flow requirements are dependent of the amount of Power Processors present in the Active Filter, operating conditions and load cycles. The following table states the maximum demanded air flow from each ADF P300 cabinet type:

Table 11: Minimum air flow requirements

Model	Maximum air flow	Maximum losses
ADF P300-120/480	600 m <sup>3</sup> /h	< 2725 W
ADF P300-240/480	1200 m <sup>3</sup> /h	< 5325 W
ADF P300-360/480	1800 m <sup>3</sup> /h	< 7925 W
ADF P300-110/480-UL	600 m <sup>3</sup> /h	< 2480 W

ADF P300-240/480-UL	1200 m <sup>3</sup> /h	< 4835 W
ADF P300-330/480-UL	1800 m <sup>3</sup> /h	< 7190 W
ADF P300-90/690	600 m <sup>3</sup> /h	< 2969 W
ADF P300-180/690	1200 m <sup>3</sup> /h	< 5813 W
ADF P300-270/690	1800 m <sup>3</sup> /h	< 8657 W
ADF P300-90/600-UL	600 m <sup>3</sup> /h	< 2836 W
ADF P300-180/600-UL	1200 m <sup>3</sup> /h	< 5547 W
ADF P300-270/600-UL	1800 m <sup>3</sup> /h	< 8258 W

It is crucial that the Active Filter can utilize the needed air flow during maximum operating conditions. The cooling air may not exceed 50 °C / 122 °F under any circumstances.



**ATTENTION:** Make sure that the ambient temperature is below 50 °C / 122 °F under all circumstances.

Make sure that the air drawn into the unit does not contain corrosive or conductive gases of any kind. Make sure that the physical mounting guidelines are followed and that no obstruction lower the air flow. Take care of the hot air emitted from the unit in a proper way.

Failure to observe these guidelines may result in premature aging or failure of the equipment.

The Active Filter contains internal fans that will ensure that the air flow reaches the needed capacity during maximum operating conditions. The emitted hot air must be taken care of by the room housing the unit. Hot air is emitted from the top of the unit.

### 4.3 Connection of the Active Filter

The Active Filter’s main connector terminals are, X10 for the power interface, X12 for CT connections and X11 for external user functionality signal interface as seen in Figure 8. Both connectors are located in the bottom of the cabinet for easy access.

#### 4.3.1 Prior to any connection

Make sure that all fuse blocks, Q1 (Q2, Q3 if applicable) and F1 are open.

##### 4.3.1.1 Prior to any connection ADF P300

The following image shows the connection area for the ADF P300 products. The conduit entry is located at the metal sheets covering the bottom of the cabinet.

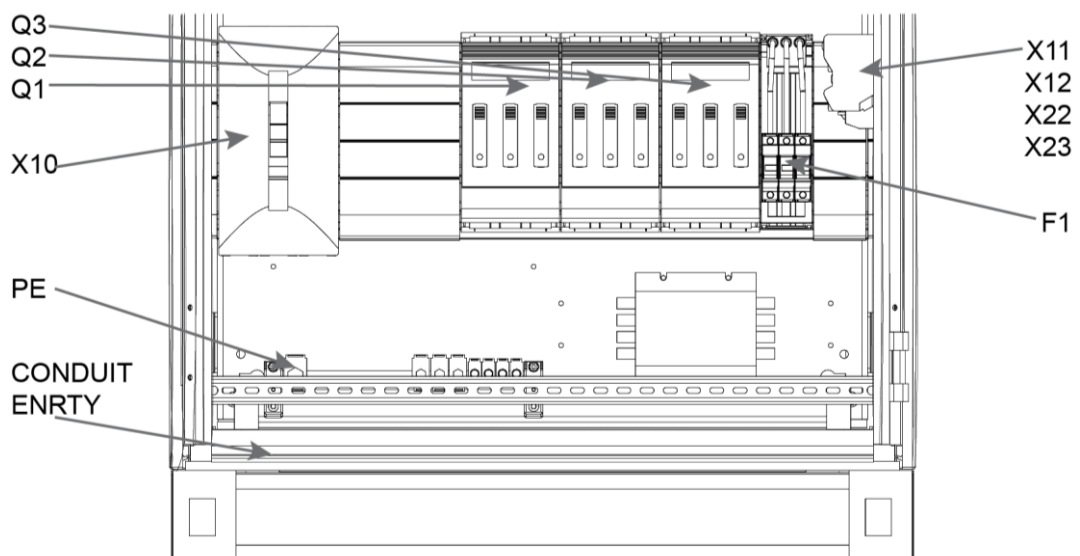

Figure 8: ADF P300, Active Filter power (X10) and user (X11/X12) connectors, Conduit Entry



### 4.3.2 Power connection terminals (X10)

The mains power connection is made at terminals X10, found in the bottom of the cabinet. The actual connections are beneath plastic covers for safety reasons. These connectors access the bus bar system feeding PP1-PP3. Note that X10 only accepts copper cables.

A second X10 can be added to the ADF. It can be ordered with the article number 100 430.

After connecting the cables, plastic covers must be remounted.

The following work flow should be followed:

1. Make sure Q1...Q3 and F1 are open.
2. Mount the cabling using the appropriate accessories. Use a torque of 12 – 14 Nm.
3. Remount the touch protection plastic cover.



**ATTENTION:** After running the Active Filter, wait at least 60 minutes after opening the pre charge circuit to guarantee that there is no residual voltage on the DC capacitors. Failure to observe these guidelines may result in injury or loss of life.

**ATTENTION:** Note that X10 only accepts Cu cable.

#### 4.3.2.1 Selection of power cable size – CE systems

In order to guarantee that the cables are not overheated some derating has to be introduced. This is due to the skin effect caused by the harmonics. The cable sizes in Table 12 are given as recommendations without warranty of suitability. The cables shall enter the cabinet from the bottom.

Table 12: Recommended cable sizes

Number of PPs	Filter capacity	Derating factor
1	90 – 150 A <sub>RMS</sub>	x 1,5
2	180 – 240 A <sub>RMS</sub>	x 1,4
3	270 - 360 A <sub>RMS</sub>	x 1,3

Note that the connectors in the ADF P300 are only approved for Copper cable. The maximum usable cable diameter on the X10 connector is 300 mm<sup>2</sup> per connector.



**ATTENTION:** The dimensions given in Table 12 only take the skin effect into consideration due to the load current being mostly harmonics. Local regulations must be observed and followed and other installation conditions which may affect the sizing of the cables, number of parallel conductors, distance and layout between conductors, and such parameters. Consult your cable manufacturer for the appropriate cable. The above guidelines are only recommendations with no warranty of suitability.

#### 4.3.2.2 Selection of power cable size - UL/cUL systems

The following types of cables are allowed for use with the ADF P300-UL:

Cable Area		Maximum allowed nominal current	Number of modules (AIR COOLED ONLY)	
mm <sup>2</sup>	AWG		480 V systems	600 V systems
120	4/0	286	2	3
150	300MCM	310	3	3

Note that no other cable types than the above dimensions are approved.



**ATTENTION:** The cable used for power terminals in UL/cUL systems must be rated for at least 75° C for twin AWG 4/0 or 90° C for a single 300MCM.

Only Copper conductors may be used.

**4.3.2.3 Surge Protection (UL/cUL versions only)**

Transient surge suppression shall be installed on the line side of this equipment, and shall be rated 480 V (phase to phase, 480 V versions) or 600 V (phase to phase, 600 V versions), suitable for overvoltage Category III, and shall provide protection for a rated impulse withstand voltage peak of 6 kV.

	<p><b>ATTENTION:</b> It is not allowed to use the UL/cUL version of the filter without external, approved surge suppression.</p>
---	--

**4.3.2.4 Branch protection (UL/cUL versions only)**

Upstream branch protection must be provided when installing the ADF P300 UL/cUL version. The ADF P300 is rated 50 kAIC. Upstream branch protection must limit fault current to 50kA.

**4.3.2.5 Main fuse selection**

The Active Filter has internal fuse blocks (Q1...Q3). If the connecting cables can handle the short circuit power of the connecting system, no fuses or breakers are needed. However local regulations may impose demands on external fusing and/or external circuit breakers. The maximum allowed short circuit power to be connected to the system is 80 kA / 1 s with the supplied fuses. If higher levels are present in the facility connected to the unit, the switchgear feeding the unit must provide a breaker or fusing capable of interrupting the short circuit power.

Standard fuses with blade contacts are used.

The fuse should be of size NH000, 250 A, 690 V aR type, such as *Cooper Bussmann CB170M1571D*.

**4.3.2.6 Auxiliary fuse selection**

The Active Filter has internal fuse blocks for protection the Auxiliary power circuit. The fuse types are defined in the below table.

Table 13 Auxiliary fuse selection

Product line 480 V, IEC	Fuse type	Brand
ADF P300	Ferrule fuse link, 10x38, aM, 500VAC, 10A	Cooper Bussman CBC10M10
Product Line 690 V, IEC		
ADF P300	Ferrule fuse link, 10x38, gG, 690VAC, 10A	Mersen FR10GG69V10
Product Line 480/600 V UL/cUL		
ADF P300	Ferrule fuse link, UL-approved class CC cat. JDDZ 10 A motor or transformer protection fuse	Cooper Bussman CBLP-CC-10

	<p><b>ATTENTION:</b> Warranty is void if the wrong fuse type is used.</p>
---	---

**4.3.3 Protective earth (PE) connection**

Connect the protective earth to the terminal (see Figure 8) in the bottom inner back of the cabinet. A cable area of at least 16 mm<sup>2</sup> is recommended. Tighten the connection with a torque of 20 Nm.

	<p><b>ATTENTION:</b> The protective earth connection must be connected to PE in the installation and NOT to the neutral (N/PEN).</p>
---	--

**4.3.3.1 Protective earth in UL/cUL systems**

The ground terminal must be connected with UL Listed ring type crimp.

**4.4 Auxiliary Transformer Setup**

The ADF P300 includes an auxiliary transformer which supplies internal circuits with 230 V<sub>AC</sub> voltage. The auxiliary transformer is marked T1 in the previous figures. The standard transformer is supplied with the following taps:

Table 14: Auxiliary standard voltages

Nominal Primary	Min input	Maximum input
208 V	188 V	228 V
400 V	360 V	440 V
480 V	432 V	528 V
600 V	540 V	660 V
690 V	621 V	725 V

Table 15: Voltage range 208 – 415 V

Nominal Primary	+15	0	-15	230	400
215 V			N	P	
230 V		N		P	
245 V	N			P	
385 V			N		P
400 V		N			P
415 V	N				P

Table 16: Voltage range 380 – 480 V

Nominal Primary	+20	0	-20	400	460
380 V			N	P	
400 V		N		P	
420 V	N			P	
440 V			N		P
460 V		N			P
480 V	N				P

Table 17: Voltage range 480 – 600 V

Nominal Primary	+25	0	-25	500	575
475 V			N	P	
500 V		N		P	
525 V	N			P	
550 V			N		P
575 V		N			P
600 V	N				P

The transformer primary is not connected when the unit is delivered from factory. Thus, it is necessary to select the proper primary winding in order to supply 230 V<sub>AC</sub> to the internal circuits. Please select a tap that is closest to the operating voltage of your system.

The connection is made by connecting the loose wire to the appropriate terminal.



**ATTENTION:** Do not use a primary voltage that differs more than 10 per cent from the nominal voltage. In case such a primary voltage must be used, order a custom transformer from Comsys AB. Please refer to the table above.

**ATTENTION:** Selecting a too low voltage will result in overheating of some components. In worst case selecting a too low voltage will cause fire.

## 4.5 User signal interface and CT terminals (X11, X12)

The external interface terminal blocks X11 and X12 located in the bottom of the cabinet (see Table 18) includes connections for current transformers (CTs), digital inputs, digital outputs and alarm output.

Table 18: External interface terminals X11 / X12

Terminal No.	Description
X12:1	S1, Current transformer L1
X12:2	S2, Current transformer L1
X12:3	S1, Current transformer L2
X12:4	S2, Current transformer L2
X12:5	S1, Current transformer L3
X12:6	S2, Current transformer L3
X11:1	Digital IN1, 24 V <sub>DC</sub>
X11:2	Digital IN2, 24 V <sub>DC</sub>
X11:3	Digital IN3, 24 V <sub>DC</sub>
X11:4	Digital IN COM GND

Terminal No.	Description
X11:5	RESERVED
X11:6	Digital OUT1 relay, NO/NC
X11:7	Digital OUT1 relay, COM/GND
X11:8	RESERVED
X11:9	RESERVED
X11:10	RESERVED (PUMP)
X11:11	RESERVED (PUMP)
X11:12	ALARM relay, NO/NC
X11:13	ALARM relay, COM
X11:14	PE

Specification for the digital output: Alarm and Digital OUT1 are the following:

- Switches 5 A at 250 V<sub>AC</sub>/30 V<sub>DC</sub>, resistive load

Do not connect external signal voltages greater than 230 V<sub>AC</sub> to the digital outputs.



**ATTENTION:** The cable used for X11 and X12 control terminals in UL/cUL systems must be rated for at least 60° C.

X12 terminals should be tightened to 1.2 – 1.4 Nm. X11 terminals should be tightened to 0.5 – 0.6 Nm.

### 4.5.1 Current transformer connection

Current transformers are connected to terminal block X12:1 – X12:6 in the bottom of the cabinet (see Figure 8). It is possible to short circuit the CT circuit with the switching jumper (1) (see Figure 9) by unscrewing the jumper and pulling them down. Observe that the CT circuit is shorted by default.

CT's are not needed in all installations. The optional sensor-less control operates without the need of CT's. In Current Control (standard), CT's are required.

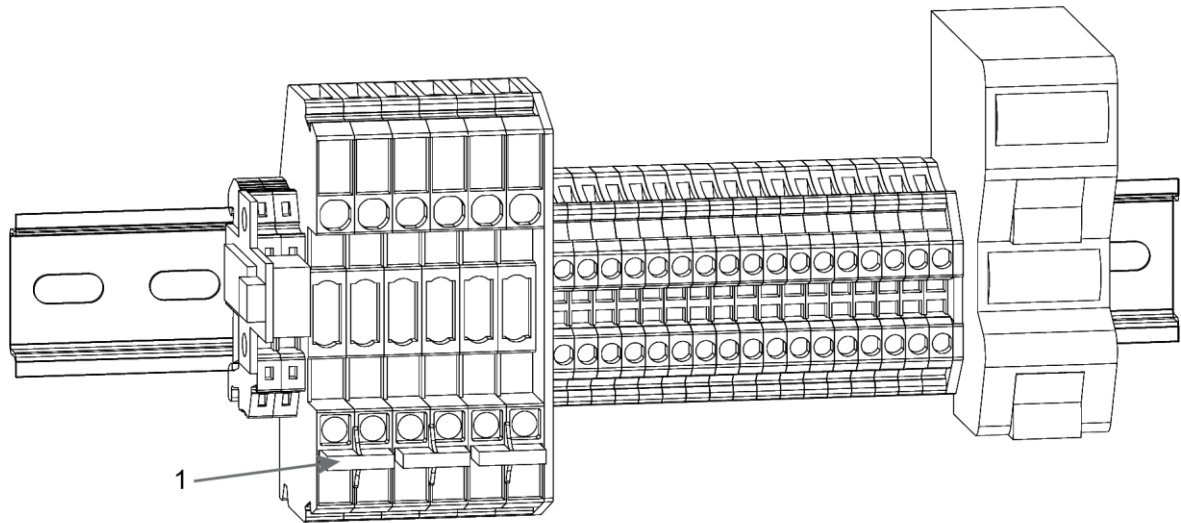

Figure 9 X11 and X12 Terminal block, CT shortened in this figure. As well as Multi-Master interface X22 and X23

#### 4.5.1.1 Selection of current transformers

The current transformers should fulfill the following specification:

Table 19: Current transformer (CT) specification

Current transformer specification	
Class	1.0 or better
Primary ratio	Exceeding the maximum load current including harmonics, reactive power, and transients
Secondary ratio	5 A maximum
ADF total CT burden	1.25 VA
Symmetry	Three identical CTs must be used

Note that the size of the CT is critical to the performance of the system. Using a very large CT in relation to the active filter size will result in poor resolution and hence poor results.



**ATTENTION:** For UL/cUL systems, the installer must use Listed Current Transformers, rated at 600 V and Secondary 5 A maximum.

#### 4.5.1.2 Recommended current transformer cable size

The recommended cable size used for connection of the current transformers is dependent of the output power of the current transformers and total length of the cables. A calculation of burden must be performed to guarantee that the burden of the CT is not exceeded. Table 20 shows the need required burden in relation to the cable size and length for some examples.

Table 20: Burden as function of cable size and length

	5 m	10 m	20 m	30 m	50 m	100 m	160 m
0.5 mm <sup>2</sup>	5.5 VA	9.7 VA	18.1 VA	26.5 VA	43.3 VA	85.3 VA	135.7 VA
0.8 mm <sup>2</sup>	4.1 VA	6.9 VA	12.5 VA	18.1 VA	29.3 VA	57.3 VA	90.9 VA
1.0 mm <sup>2</sup>	3.4 VA	5.5 VA	9.7 VA	13.9 VA	22.3 VA	43.3 VA	68.5 VA
1.5 mm <sup>2</sup>	2.7 VA	4.1 VA	6.9 VA	9.7 VA	15.3 VA	29.3 VA	46.1 VA
2.5 mm <sup>2</sup>	2.1 VA	3.0 VA	4.7 VA	6.3 VA	9.7 VA	18.1 VA	28.2 VA
4.0 mm <sup>2</sup>	1.8 VA	2.3 VA	3.4 VA	4.4 VA	6.5 VA	11.8 VA	18.1 VA
6.0 mm <sup>2</sup>	1.6 VA	2.0 VA	2.7 VA	3.4 VA	4.8 VA	8.3 VA	12.5 VA
10.0 mm <sup>2</sup>	1.5 VA	1.7 VA	2.1 VA	2.6 VA	3.4 VA	5.5 VA	8.0 VA

Table 21 ADF CT connection data

ADF CT connection data	
Conductor cross section solid min.	0.5 mm <sup>2</sup>
Conductor cross section solid max.	10 mm <sup>2</sup>
Conductor cross section stranded min.	0.5 mm <sup>2</sup>
Conductor cross section stranded max.	6 mm <sup>2</sup>

### 4.5.1.3 Location of current transformers

The location of the current transformers is critical to the function of the Active Filter. The following guidelines should be observed for proper operation:

Closed loop control is preferred. This means that the CTs monitor the load current and the Active Filter current. However, open loop control is also possible – meaning that the CTs are placed downstream to the mains connection of the Active Filter unit.

Beside the current control in, in open and closed loop, the ADF systems also support the optional sensor-less control.

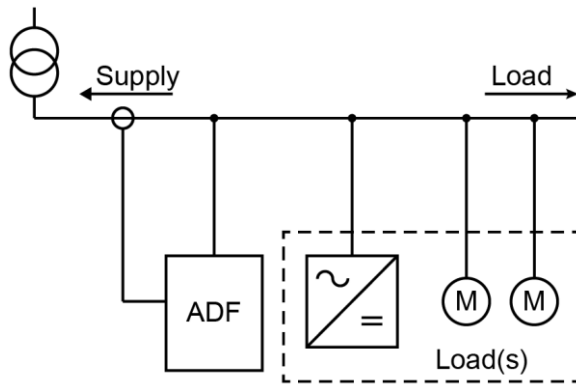

Figure 10: Current Transformer placement diagram – closed loop

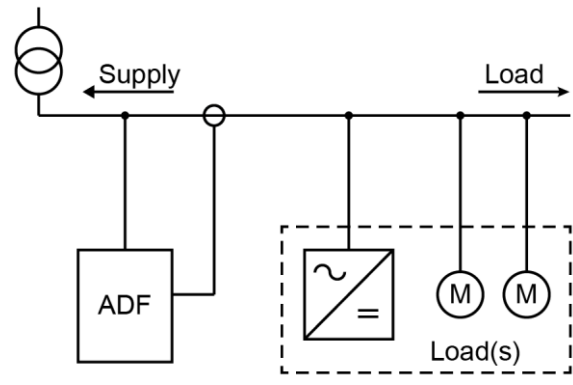

Figure 11: Current Transformer placement diagram – open loop

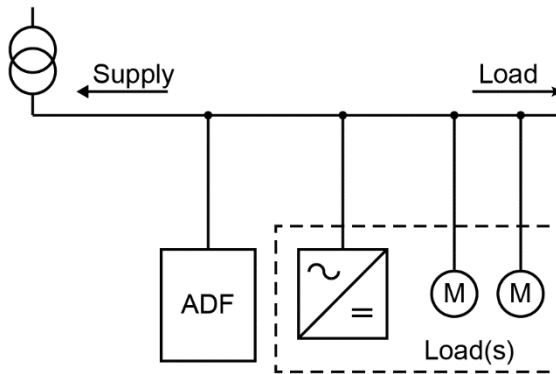

Figure 12: No current transformer in sensor-less control



**ATTENTION:** Never open the circuit of a connected current transformer. During all connection work, short circuit the secondary of the current transformers.

Failure to short circuit the current transformers may cause dangerous voltages, arcs and destruction of the current transformers. When connection is complete, the short circuit must be removed.

**4.5.1.4 Connection and wiring of current transformers**

- The S1 terminal of each CT must be oriented to the supply side. The S2 of each CT must be oriented toward the load side.
- The CTs must be grouped properly phase wise with the corresponding mains connection. This means that the connected to phase 1 on X12 must monitor the current corresponding to phase L1 of the network line connection.
- The phases must be connected in proper rotation. L2 must lag L1, L3 must lag L2 and L1 must lag L3.
- Either S1 or S2 must be individually connected to PE (Protective Earth). The connection must be performed identically for each CT.
- The connection is made to terminal block X12:1 through X12:6.
- When using the Active Filter in conjunction with a passive filter, special requirements apply. See “Appendix B Compatibility with passive compensation” for further information.

The wiring should be connected according to Table 22.

Table 22: CT connection table

Phase	Current transformer	Terminal block
Phase L1 / A	S1	X12:1
	S2	X12:2
Phase L2 / B	S1	X12:3
	S2	X12:4
Phase L3 / C	S1	X12:5
	S2	X12:6

In Figure 13, the correct connection of mains power and current transformers with correct grounding is illustrated. The example shows close loop operation.

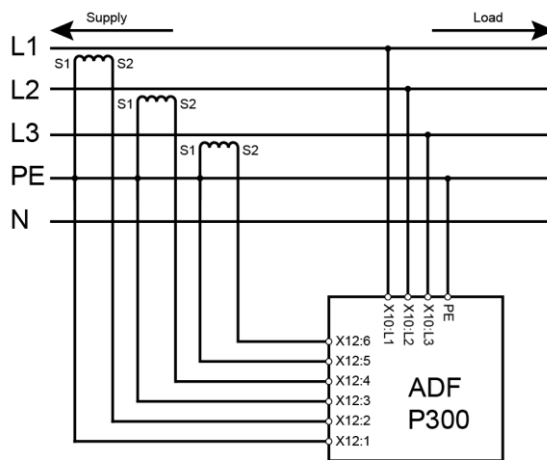

Figure 13: Current Transformer connection diagram – closed loop

**4.5.1.5 Connection of current transformers with paralleled systems**

Figure 14 illustrates correct connection of two paralleled Active Filters, again in closed loop operation with correct grounding:

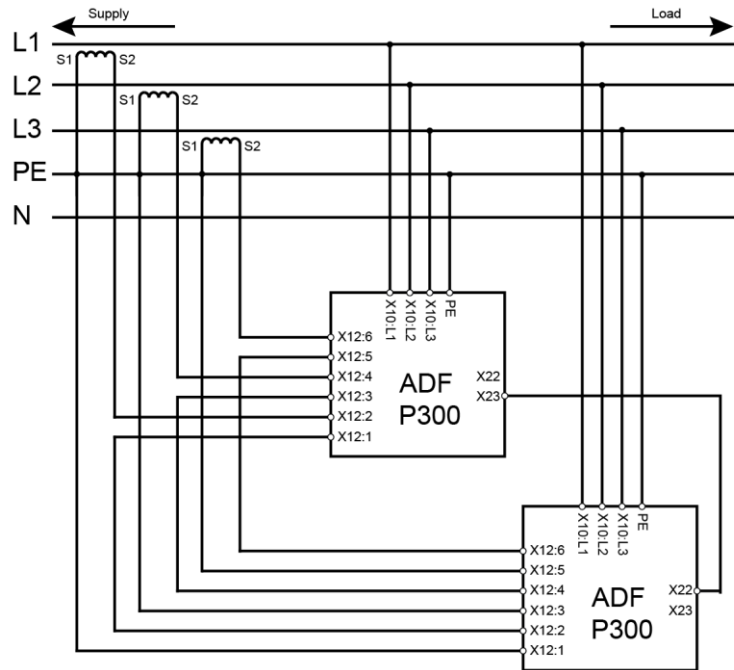

Figure 14: Current Transformer connection diagram – paralleled units

#### 4.5.1.6 Use of summation transformers

Summation transformers can be used in certain configurations. Some examples of usable scenarios:

- When compensating loads, in closed loop operation, fed by two or more transformers which are paralleled. The secondary sides must then be added to the current input of the ADF P300 using a summation transformer.
- When compensating loads, in open loop configuration, where the main CTs must be placed on two or more outgoing groups.

In all cases, when using summation CT's, the ratio must be selected so that full signal corresponds to 5 A on the secondary of the summation transformer going into the X12 terminal block.

#### 4.5.2 Multi-master bus (X22 & X23; optional)

The RJ45 sockets are used for inter-ADF communication for example when several ADFs are operated in parallel in Multi-Master operation. ADFs are connected as a daisy-chain with termination plugs in each end of the chain like shown in figure below. X22 and X23 are freely interchangeable.



Figure 15: Example setup for Multi-Master operation

A “FTP category 5” or better Network cable can be used to connect ADF's to each other. The maximum length of the entire cable is 100 m / 328 ft.



**ATTENTION:** The electrical interface of the RJ45 Multi-Master connectors is different from that of the LAN. Be sure to only connect equipment approved by Comsys on this bus or equipment damage may result.



## 5 Maintenance

The following chapter covers routine maintenance of all ADF P300 versions.

Every 6 months, a routine inspection is performed. In most cases, no components are exchanged during biannual inspection.

**NOTE** Warranty is void if maintenance is not performed according to schedule.



**ATTENTION:** All maintenance must be performed by trained and qualified personnel.

Make sure no voltage is present in main circuit, auxiliary power system, AC voltage measurement circuits and power capacitors.

Follow the guidelines for preparing the ADF P300 for maintenance before attempting to perform any work in this section.

ADF P300 consists of electronics sensitive to electrostatic voltage.

When tightening electrical or mechanical connections be sure to apply the correct torque.

Before attempting any maintenance, the ADF P300 must be shut down.

### 5.1 Biannual inspection

The following items are included in the maintenance procedure:

- Visual inspection
- Cleaning
- Inspection of fuses
- Cooling system
- Door, lock inspection
- Air filter
- Electrical connections

#### 5.1.1 Visual inspection

All cabinets should be opened. A visual inspection must be performed of all cabinets in the system. Check for any of the following items:

- Dust
- Condensation
- Abnormal smell, discoloration, soot or swelling of components
- Cracks in plastic covers
- Inspect DC capacitors for signs of overheating; be aware of swollen capacitors and signs of overheating. Such capacitors must be replaced.

Pay particular attention to presence of conductive dust.

#### 5.1.2 Cleaning

All dust must be removed. The best way of doing this is to use pressurized air (from a compressor system).



**ATTENTION:** The equipment is sensitive to ESD. Avoid cleaning the system with any method which may cause build-up of ESD; such as vacuum cleaning, using cloths, etc.

Dust build-up may cause unreliability and component failure in the worst case.

Check the air filter and exchange them if necessary.

### **5.1.3 Fuses**

Inspect all fuses, check for signs of premature wear. If fuses have been used during abnormal situations causing overheating and/or overcurrent, replace the fuses.

The following fuses should be inspected:

- Main fuses connecting PPs to the main bus bar (Q1...Q3)
- DC link fuses
- Fuses on ACB
- Auxiliary fuse block (F1)

### **5.1.4 Cooling system**

Check the fans by holding a piece of paper on top of each outlet. The outlets are located on the top of the cabinet, below the roof, close to the back of the cabinet.

### **5.1.5 Door, lock inspection**

Inspect door and locks, including the seals. Check that the lock operates without problem and that the door is fully closed and in contact with the whole frame when the lock is enabled. If the door is not tight, the cooling will not work correctly.

### **5.1.6 Air filter**

Inspect the air filter and exchange them if the dirt restricts the airflow. The exchange schedule can vary a lot depending on the air pollution at site.

### **5.1.7 Electrical connection**

Visually inspect all electrical connections. Check for signs of heated cable terminations and damaged insulation.

Check the torque on mains connections and PE.

## Appendix A Technical Specifications

### A.1 Technical Data – ADF P300-XXX/480

Table 23: Technical specifications ADF P300-XXX/480

<b>Characteristics</b>			
Model	ADF P300-120/480	ADF P300-240/480	ADF P300-360/480
Rated power, nominal 400 V / 480 V	83 kVA / 100 kVA	166 kVA / 200 kVA	249 kVA / 299 kVA
Compensation current capacity at 50/60 Hz	120 A <sub>RMS</sub>	240 A <sub>RMS</sub>	360 A <sub>RMS</sub>
System voltage *	208 – 480 V		
Nominal frequency *	50/60 Hz ± 2 %		
Number of phases	3 phase 3 wire		
Connection type	3 phase without neutral (TN, TT, IT)		
Harmonic current compensated	individual compensation up to 49 <sup>th</sup> order		
Rate of harmonic reduction	better than 98 %		
Current compensation of cos φ	up to 1.0		
Expandability	ADF P300 units can be used in parallel		
Response time	< 1 ms		
Power dissipation	< 2725 W	< 5325 W	< 7925 W
Maximum air flow requirement	600 m <sup>3</sup> /h	1200 m <sup>3</sup> /h	1800 m <sup>3</sup> /h
Noise level	< 70 dB (A)		
Environment	0 to 95 % RH non-condensing, max. altitude 1000 m (3300 ft)		
Operation temperature	0 °C to 50 °C, up to 40 °C without derating 32 °F to 122 °F, up to 104 °F without derating		
Dimensions	800 x 2155 x 610 mm (W x D x H) 31,5" x 84,8" x 24" (W x D x H)		
Weight	335 kg	472 kg	609 kg
Cabinet color	cabinet RAL 7035 (gray), base RAL 7022 (dark gray)		
Protection class	IP21 according to IEC 529		
Environmental conditions	chemical 3C3, mechanical 3S3		
Electromagnetic compatibility	EN 61000-6-2, EN 61000-6-4		
Certificates	CE		

\* please state your system voltage and line frequency when ordering

## A.1 Technical Data – ADF P300-XXX/480 – UL/cUL version

Table 24: Technical specifications ADF P300-XXX/480

<b>Characteristics</b>			
Model	ADF P300-100/480-UL	ADF P300-200/480-UL	ADF P300-300/480-UL
Rated power, nominal 400 V / 480 V	76 kVA / 91 kVA	152 kVA / 183 kVA	229 kVA / 274 kVA
Compensation current capacity at 50/60 Hz	110 A <sub>RMS</sub>	220 A <sub>RMS</sub>	330 A <sub>RMS</sub>
Short Circuit Rating	50 kAIC		
System voltage *	208 – 480 V		
Nominal frequency *	50/60 Hz ± 2 %		
Number of phases	3 phase 3 wire		
Connection type	3 phase without neutral (TN, TT, IT)		
Harmonic current compensated	individual compensation up to 49 <sup>th</sup> order		
Rate of harmonic reduction	better than 98 %		
Current compensation of cos φ	up to 1.0		
Expandability	ADF P300 units can be used in parallel		
Response time	< 1 ms		
Power dissipation	< 2480 W	< 4835 W	< 7190 W
Maximum air flow requirement	600 m <sup>3</sup> /h	1200 m <sup>3</sup> /h	1800 m <sup>3</sup> /h
Noise level	< 70 dB (A)		
Environment	0 to 95 % RH non-condensing, max. altitude 1000 m (3300 ft)		
Operation temperature	0 °C to 50 °C, up to 40 °C without derating 32 °F to 122 °F, up to 104 °F without derating		
Dimensions	800 x 2155 x 610 mm (W x D x H) 31,5" x 84,8" x 24" (W x D x H)		
Weight	335 kg	472 kg	609 kg
Cabinet color	cabinet RAL 7035 (gray), base RAL 7022 (dark gray)		
Protection class	NEMA Type 1 IP21 according to IEC 529		
Environmental conditions	chemical 3C3, mechanical 3S3		
Electromagnetic compatibility	EN 61000-6-2, EN 61000-6-4		
Certificates	UL, cUL		

\* please state your system voltage and line frequency when ordering

## A.2 Technical Data – ADF P300-XXX/690

Table 25: Technical specifications ADF P300-XXX/690

<b>Characteristics</b>			
Model	ADF P300-90/690	ADF P300-180/690	ADF P300-270/690
Rated power, nominal 600 V / 690 V	94 kVA / 108 kVA	187 kVA / 215 kVA	281 kVA / 323 kVA
Compensation current capacity at 50/60 Hz	90 A <sub>RMS</sub>	180 A <sub>RMS</sub>	270 A <sub>RMS</sub>
System voltage *	480 – 690 V		
Nominal frequency *	50/60 Hz ± 2 %		
Number of phases	3 phase 3 wire		
Connection type	3 phase without neutral (TN, TT, IT)		
Harmonic current compensated	individual compensation up to 49 <sup>th</sup> order		
Rate of harmonic reduction	better than 98 %		
Current compensation of cos φ	up to 1.0		
Expandability	ADF P300 units can be used in parallel		
Response time	< 1 ms		
Power dissipation	< 2969 W	< 5813 W	< 8657 W
Maximum air flow requirement	600 m <sup>3</sup> /h	1200 m <sup>3</sup> /h	1800 m <sup>3</sup> /h
Noise level	< 70 dB (A)		
Environment	0 to 95 % RH non-condensing, max. altitude 1000 m (3300 ft)		
Operation temperature	0 °C to 50 °C, up to 40 °C without derating 32 °F to 122 °F, up to 104 °F without derating		
Dimensions	800 x 2155 x 610 mm (W x D x H) 31,5" x 84,8" x 24" (W x D x H)		
Weight	351 kg	495 kg	639 kg
Cabinet color	cabinet RAL 7035 (gray), base RAL 7022 (dark gray)		
Protection class	IP21 according to IEC 529		
Environmental conditions	chemical 3C3, mechanical 3S3		
Electromagnetic compatibility	EN 61000-6-2, EN 61000-6-4		
Certificates	CE		

\* please state your system voltage and line frequency when ordering

## A.2 Technical Data – ADF P300-XXX/600 – UL/cUL version

Table 26: Technical specifications ADF P300-XXX/600

<b>Characteristics</b>			
Model	ADF P300-90/600-UL	ADF P300-180/600-UL	ADF P300-270/600-UL
Rated power, nominal 600 V	94 kVA	187 kVA	281 kVA
Compensation current capacity at 50/60 Hz	90 A <sub>RMS</sub>	180 A <sub>RMS</sub>	270 A <sub>RMS</sub>
Short Circuit Rating	50 kAIC		
System voltage *	480 – 600 V		
Nominal frequency *	50/60 Hz ± 2 %		
Number of phases	3 phase 3 wire		
Connection type	3 phase without neutral (TN, TT, IT)		
Harmonic current compensated	individual compensation up to 49 <sup>th</sup> order		
Rate of harmonic reduction	better than 98 %		
Current compensation of cos φ	up to 1.0		
Expandability	ADF P300 units can be used in parallel		
Response time	< 1 ms		
Power dissipation	< 2836 W	< 5547 W	< 8258 W
Maximum air flow requirement	600 m <sup>3</sup> /h	1200 m <sup>3</sup> /h	1800 m <sup>3</sup> /h
Noise level	< 70 dB (A)		
Environment	0 to 95 % RH non-condensing, max. altitude 1000 m (3300 ft)		
Operation temperature	0 °C to 50 °C, up to 40 °C without derating 32 °F to 122 °F, up to 104 °F without derating		
Dimensions	800 x 2155 x 610 mm (W x D x H) 31,5" x 84,8" x 24" (W x D x H)		
Weight	351 kg	495 kg	639 kg
Cabinet color	cabinet RAL 7035 (gray), base RAL 7022 (dark gray)		
Protection class	NEMA Type 1 IP21 according to IEC 529		
Environmental conditions	chemical 3C3, mechanical 3S3		
Electromagnetic compatibility	EN 61000-6-2, EN 61000-6-4		
Certificates	UL, cUL		

\* please state your system voltage and line frequency when ordering

## Appendix B Compatibility with passive compensation

Capacitor banks are often used in various configurations to lower the reactive power in an installation. It is a recognized problem that capacitor impedance falls with rising frequency and hence act as a sink for harmonics.

It is **not recommended** to use Active Filter units in conjunction with direct connected passive compensation without series reactors. Detuned capacitor banks are easier to integrate with Active Filters.

In all cases, the capacitor bank should be connected prior to the current measurement used for the Active Filter, as illustrated in Figure 16 below. When using the Active Filter in conjunction with detuned capacitor banks, it is strongly recommended to configure the Active Filter for closed loop current measurement.

The passive compensation **must** be placed upstream to the Active Filter.

Note that the Active Filter unit's current transformers (CTs) are placed prior to the load, but after the passive compensation, viewing from the supply side.

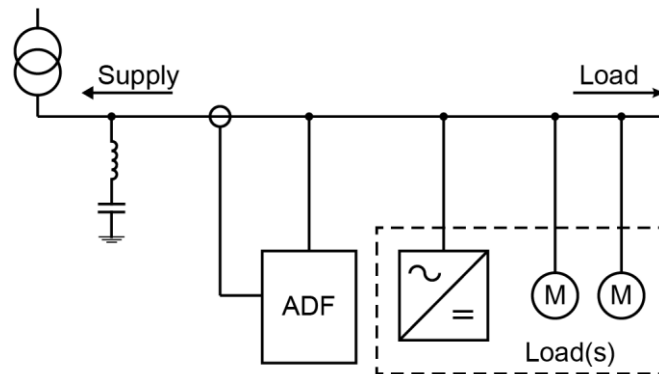

Figure 16: Connection of an Active Filter unit, passive compensation, and location of CTs.



**ATTENTION:** Failure to observe the orientation guidelines above will significantly shorten the lifetime of the passive compensation, lower the efficiency of both the Active Filter unit and the passive compensation, and may cause unpredictable results.

## Appendix C Harmonics derating

The current rating of Active Filter units is specified at the system frequency (50 or 60 Hz). This is sufficient in all normal applications since higher harmonics are lower in amplitude in most cases. For special application, requiring very high harmonic current in high harmonic orders, special care must be taken. A rating of 120 A<sub>RMS</sub> does not imply that the unit can output 120 A<sub>RMS</sub> @ 1250 Hz (25<sup>th</sup> harmonic in a 50 Hz system).

The following guidelines are useful for determining the maximum allowable higher harmonic current during normal operation of Comsys Active Filters.

### C.1 Single harmonic maximum current

The following guidelines are established for maximum continuous current only when the unit is running at maximum rated ambient temperature. During dynamic operation with lower ambient temperature than the maximally allowed, burst currents may be significantly higher. In the same fashion, in continuous operation at temperatures higher than the maximum allowed, the unit automatically derates the output in order to not shorten component lifetime.

The following table can be used to determine the maximum individual current, as percentage of the rated maximum compensation current:

Table 27: Maximum current output on single harmonics

h	Output (%)	h	Output (%)	h	Output (%)
1	100 %	19	60 %	37	40 %
3	100 %	21	55 %	39	35 %
5	100 %	23	55 %	41	35 %
7	100 %	25	50 %	43	35 %
9	90 %	27	45 %	45	30 %
11	80 %	29	45 %	47	30 %
13	75 %	31	40 %	49	30 %
15	70 %	33	40 %		
17	65 %	35	40 %		

In the given table, h is the harmonic order. For a unit rated at 120 A<sub>RMS</sub>, the maximum current of the 23<sup>rd</sup> harmonic is consequently 66 A<sub>RMS</sub>.



## C.2 Determining the thermal limit

Given that each harmonic current is within the limits outlined above, the total limit of the system as a whole can be determined as follows. First, calculate the individual contribution of each harmonic:

$$I_{h,contrib} = I_h / \text{OUT}(\%,h)$$

where h is the harmonic order and  $I_h$  is the corresponding current. Finally, add the individual harmonic contributions as a root sum:

$$I_{total} = \text{SQRT}(I_{3,contrib}^2 + I_{5,contrib}^2 + \dots + I_{49,contrib}^2 + I_{reactive,contrib}^2)$$

The answer is the amount of unit current rating needed to be able to compensate the load. Eventual reactive current can be added in the formula above as  $I_{reactive,contrib}$ .

### Example:

A load needs 85 A<sub>RMS</sub> at the 5<sup>th</sup> harmonic and 50 A<sub>RMS</sub> at 7<sup>th</sup> harmonic. The individual contributions are  $I_{5,contrib} = 85 \text{ A}_{RMS} / 100 \% = 85 \text{ A}_{RMS}$  for fifth harmonic and  $I_{7,contrib} = 50 \text{ A}_{RMS} / 100 \% = 50 \text{ A}_{RMS}$  for the seventh harmonic. The RMS sum of the two components are 98.6 A<sub>RMS</sub>. Thus, a 100 A unit will be sufficient to compensate the load. Adding an 11<sup>th</sup> harmonic of 35 A<sub>RMS</sub> adds an equivalent contribution of 43.8 A<sub>RMS</sub> yielding a total needed capacity of 107.8 A<sub>RMS</sub> which will not work in a 100 A unit in continuous operation at maximum allowed ambient temperature.

## C.3 Summary

In most cases the above guidelines are sufficient to establish the needed Active Filter size in order to fully compensate the desired harmonics. Since the exact calculations are complex the guidelines established in this document can be considered safe limits.

For detailed calculations or custom solutions, please contact your Comsys ADF supplier.

The formulas and guidelines are valid for all ADF P300 Active Filters systems up to the 49<sup>th</sup> harmonic.

## Appendix D Altitude derating

The current rating of the ADF units is specified up to a height of 1000 m / 3281 ft. In higher altitudes the current rating will be lowered depending on the height. The following rules apply when using ADF units above altitudes of 1000 m / 3281 ft:

### D.1 Air cooling derating

When using a ADF P300 on heights above 1000 m, the maximum output will be derated according to the following:

$$\text{Altitude derating [\%]} = (h - 1000) / 100 \quad (h = \text{height in meter})$$

$$\text{Altitude derating [\%]} = (h - 3281) / 328 \quad (h = \text{height in feet})$$

For example, at an altitude of 1500 m, the derating will be 5 %. In this case a ADF P300-240 will not have the capability to compensate 240 A<sub>RMS</sub> but only 228 A<sub>RMS</sub>.





**Comsys AB**  
Fältspatvägen 4  
SE-224 78 LUND, Sweden  
Tel +46 (0)10 209 68 00  
Fax +46 (0)10 209 68 05  
E-mail: [info@comsys.se](mailto:info@comsys.se)  
website: [www.comsys.se](http://www.comsys.se)

**Partner:**

Comsys AB does not assume any responsibility for use of any product or method described and also reserves the right to make changes at any time without prior notice in order to improve design and supply the best possible products.