

Leading PF and capacitive reactive power problem in Data Center

Data Center as the main part of communication and financial industry, has very high requirement for the reliability of electrical power system. The data loss due to the power cut will lead to inestimable loss. So UPS becomes the standard equipment in every Data Center. There are mainly two types of UPS. One is 50Hz UPS and the other one is high frequency UPS. Since the high frequency UPS is cheaper and more efficient than 50Hz UPS, high frequency UPS has been widely used in Data Center now. But it comes with the new problem because the electrical characteristic of the high frequency UPS. It is the high frequency UPS could cause leading PF in the system, which could not be solved by conventional capacitor banks.

High frequency UPS has the LC filter circuit in the input side to avoid generating harmonic into grid during operation. the filter capacitor in the LC filter circuit will generate capacitive reactive power to the system grid when system voltage supply on filter capacitor. It is the reason why it appears leading PF in the UPS input side, If there is only a small amount of UPS in the data Center system , which will be not a severe, But if there is a large amount of UPS distributed in system , which will leads to leading PF in the whole Data Center.

The topology of high frequency UPS and filter capacitor in the inputside is as below shows:

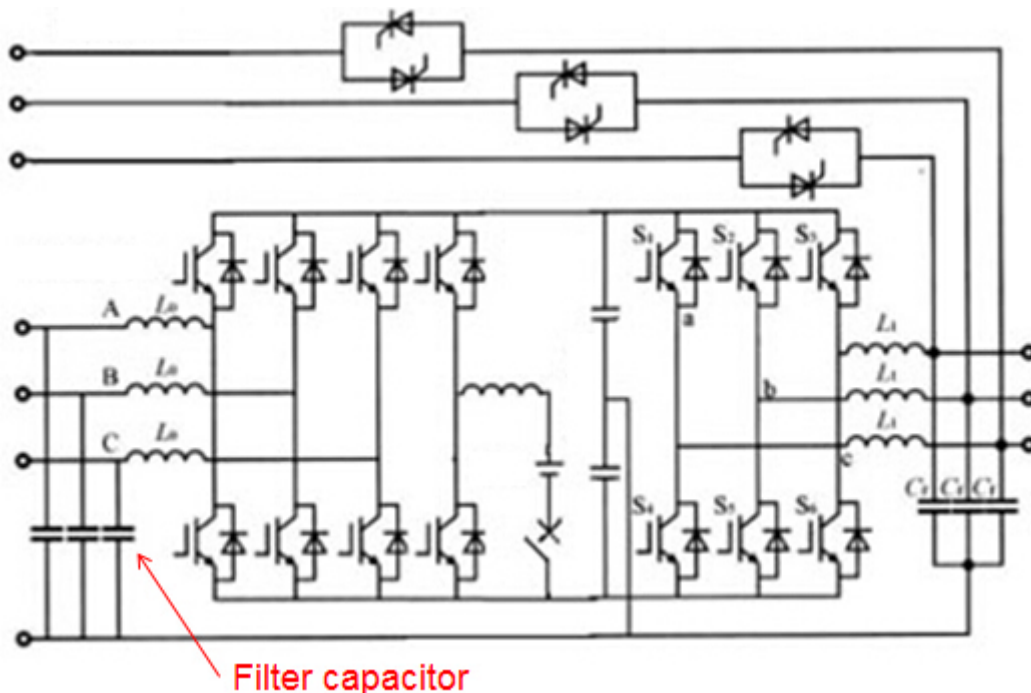

How does Leading PF impact Data Center?

1. Conventional capacitor banks solution could not compensate capacitive reactive power and could not improve leading PF. Because capbank can only inject capacitive power to compensate inductive power of system, so It will cause penalty when PF is lower than 0.9.

2. Usually there are Diesel Generators in Data Center to avoid unpredictable system power cut, in case there is a power cut and UPS battery out of power. And one of the characteristic of diesel generator is that if the capacitive reactive power is too large in the system, Diesel Generator could not connect to the grid to power on. In this case, if there is a power cut, UPS start to supply power to the loads. In the meanwhile, Diesel Generator connect to the grid to power on. If there is too much capacitive reactive power in the system, Diesel Generator will stop automatically and restart and repeat these actions. Data Center will face total power off if UPS battery is power off and Diesel Generator could not connect to the grid to power on due to the capacitive reactive power in the system.

Normally, The limit of capacitive reactive power for the Diesel Generator under full load condition is the system leading PF 0.9, which means if the leading PF is lower than 0.9 when it work in full load , Diesel Generator could not connect to the grid to power on to work.

3. Capacitive reactive power will affect the excitation system so that affect the output voltage of the Diesel Generator, which will affect the output capability of the Diesel Generator. When system leading PF is around 0.9, there will be a considerable decrease in the Diesel Generator output capability.

All in all, the two main impact of capacitive reactive power in Data Center, one is the penalty because of low PF. The other one is the affecting of the starting and normal operation for Diesel Generator.

Under this special circumstance, Sinexcel SVG bi-directional compensation capability (compensating both leading and lagging PF) would be a best solution for Data Center! Below sharing the advantages for Sinexcel SVG comparing with conventional capacitor banks:

- 0.99~1 PFC performance
- -1~1 both capacitive and inductive(leading and lagging) load PF compensation
- Step-less compensation, 15ms to finish PFC
- No resonance, No over/under compensation. Applicable for complicated and fast switching applications.
- will not be impacted by harmonic, will not generate harmonic, either
- High power up to 100Kvar/module
- Modular design concept, could be integrated into self-design cabinet, the same as capacitor bank
- Rating power is equal to compensation power
- Compensation reactive current would not be reduced by voltage drop