

User Manual

SVGD

Version: 1.0
2019-10-12

Index of Contents

Chapter I Safety Instructions	1
Chapter II Use Environment	1
Chapter III SVGD scheme principle	2
3.1 Installation and testing	2
3.2 size and interface	2
3.3 Appearance	3
Chapter IV SVGD scheme principle	4
4.1 Multiple SVG + SVGD Scheme	5
4.2 Parameter setting	7

Chapter I Safety Instructions

1. This manual covers the installation and use of SVGD. Please read this manual before installation.
2. The SVGD must be commissioned and maintained by engineers designated by the manufacturer or its agent. Failure to do so may endanger personal safety and cause equipment malfunction. The resulting SVGD damage and other malfunctions are not covered by the warranty and our responsibility.
3. The installation of this unit must comply with all relevant safety procedures. The correct wiring and wire size must be used to ensure operational safety and operational reliability as well as measurement accuracy.
4. The power input side will generate high voltage that is harmful to personal safety. Care should be taken during operation and strict safety procedures should be followed.
5. When collecting data while in a charged state, do not touch the live part under any circumstances.

Chapter II Use Environment

Air temperature: air temperature is not higher than $+40^{\circ}\text{C}$, not lower than -10°C , humidity: $\leq 95\%$, no condensation

Altitude: no more than 2500 meters

Environmental conditions: The surrounding environment is free of flammable and explosive media, no corrosive gas, no conductive dust, rain and snow erosion, and the installation site cannot be shaken vigorously.

Storage temperature: no higher than 70°C , not lower than -40°C

Chapter III SVGD scheme principle

3.1 Installation and testing

Before opening the package of this unit for installation, you should carefully check for signs of damage, check the accessories and instructions are complete, if you find any problems, please contact with the supplier in time.

Connect to the power supply, check whether the operation function and display are normal under power-on status.

3.2 size and interface

SVGD enclosure, the dimension is 212.5×120.4×45mm (W×D×H) please refer to “figure 3.1”

The terminals outside of SVGD are:

- Grid voltage sampling input – A, B, C, N of three-phase four-wire (for three-phase three-wire system, N line cannot be connected);
- Grid current sampling input – CT input;
Connect to SVG – connect to SVG;
- Connect to monitor – connect to 7-inch monitor screen;

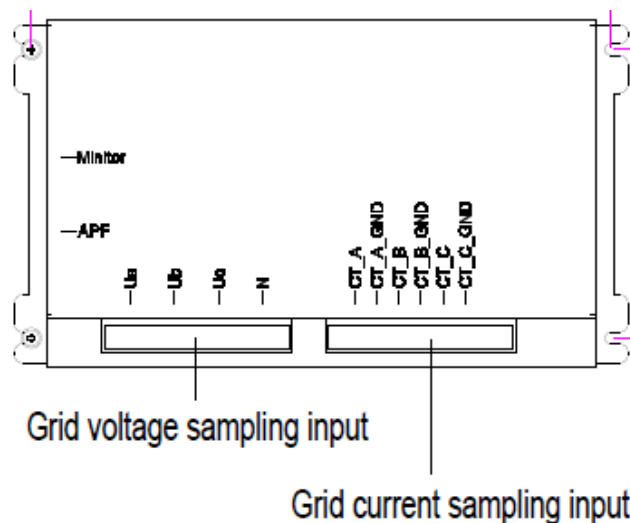

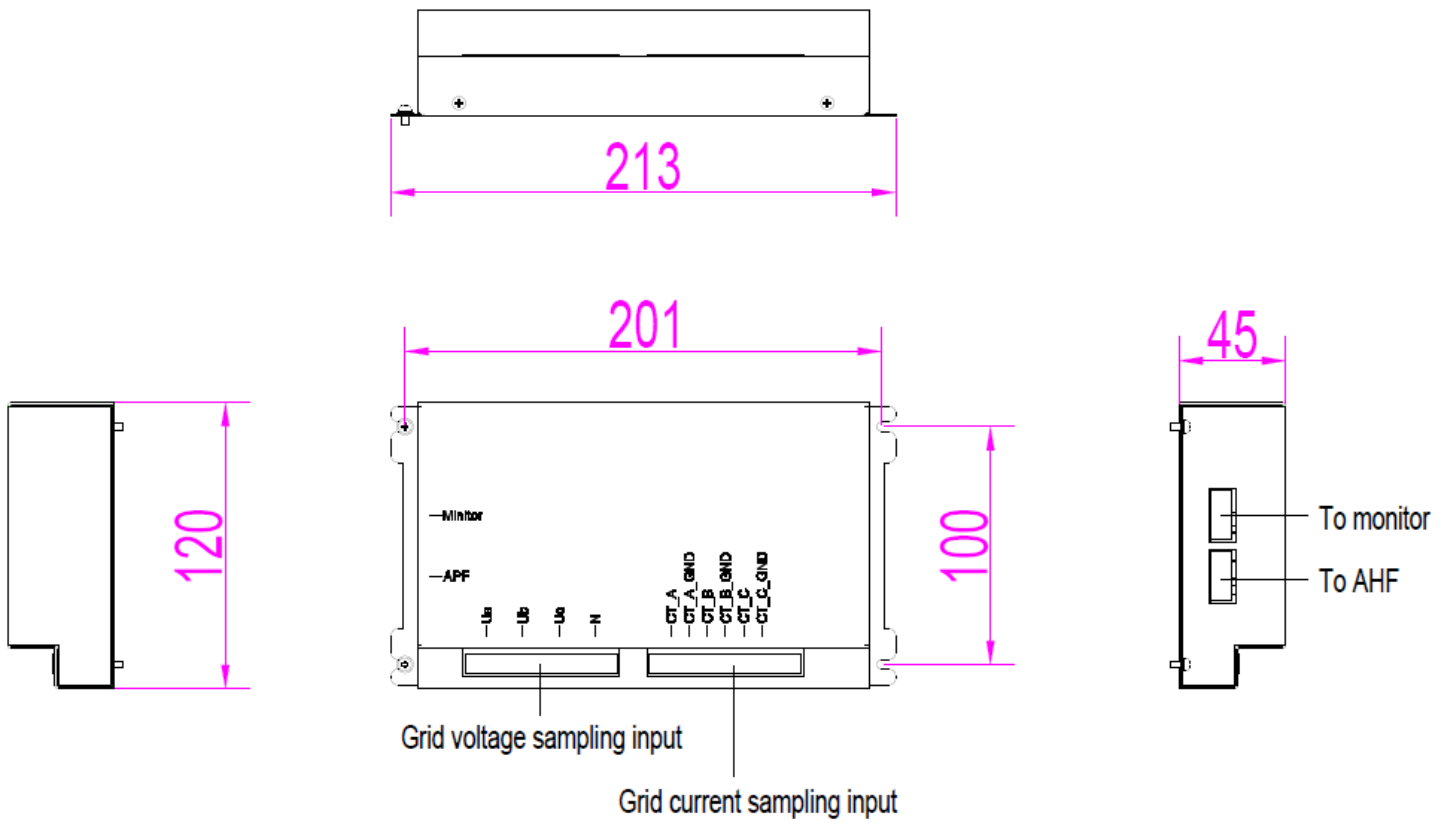
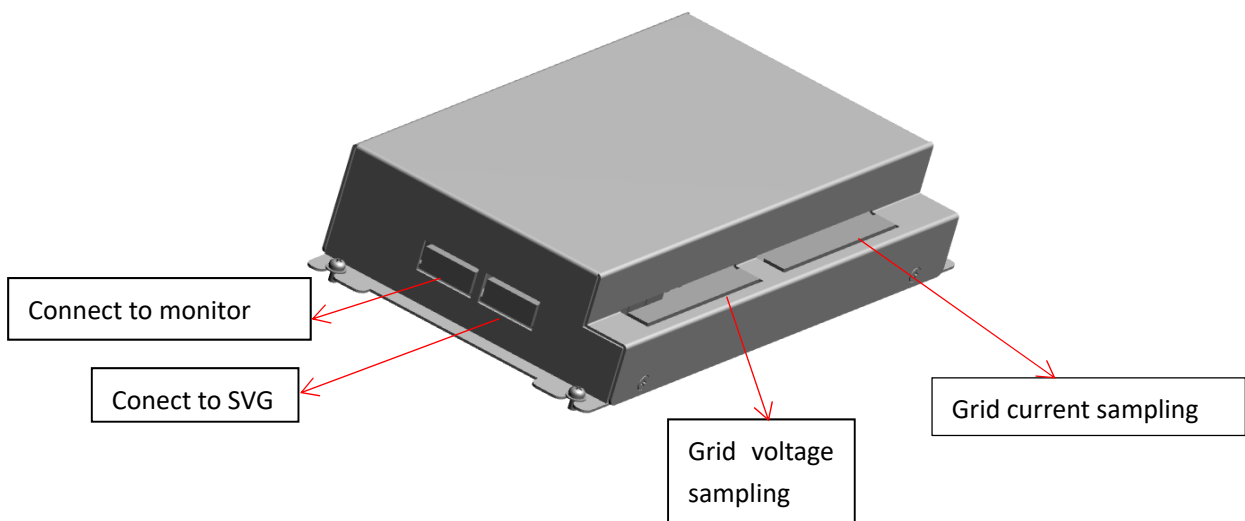

Figure 3.1 Size and interface

3.3 Appearance

SVG appearance is as follows:



Chapter IV SVGD scheme principle

The following figure shows the backplane interface of SVG.

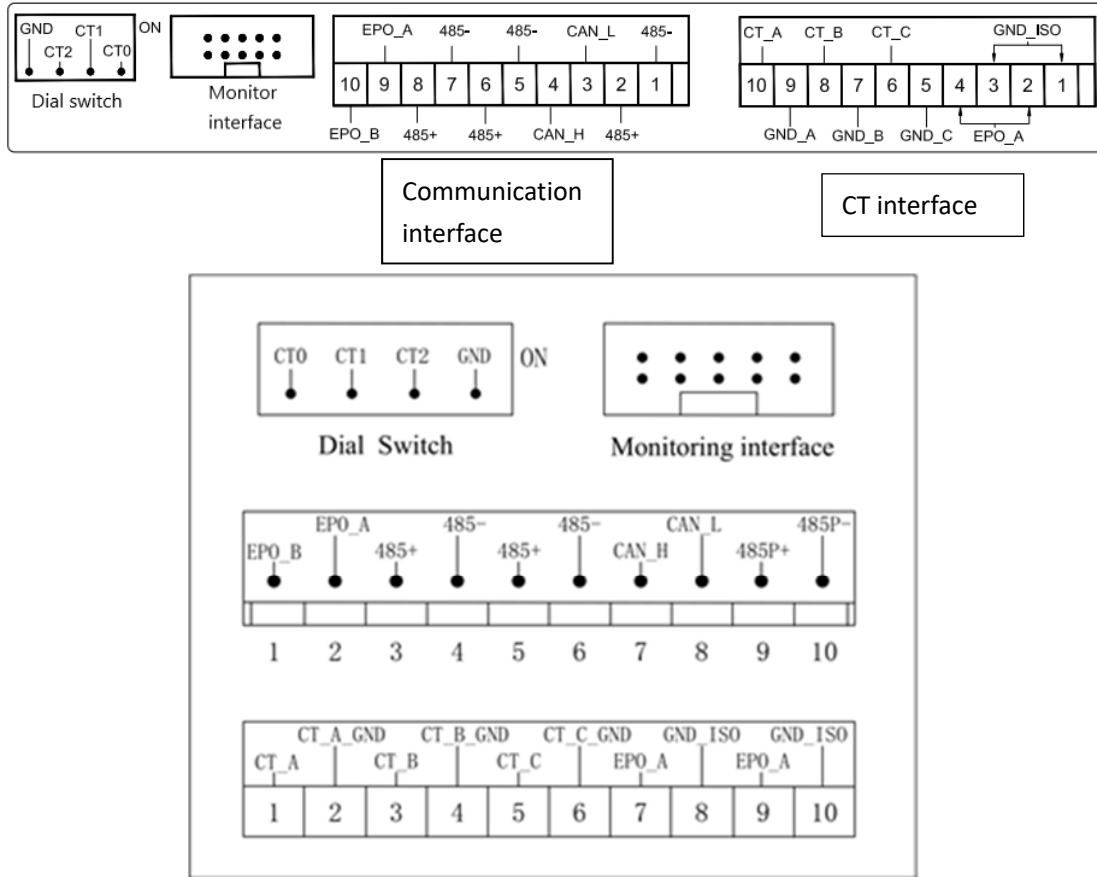

4.1 Multiple SVG + SVGD Scheme

The SVG+SVGD scheme and wiring diagram are shown in Figure 4.1 below. The working principle is as follows: SVGD control board samples grid voltage and samples grid current through CT, analyze and calculate the reactive current in the power grid, communicate with SVG through communication cable, then SVG switch in and compensate the reactive power. At the same time, 7-inch central monitor is connected to SVGD control board to realize real-time display of parameters and status of SVG such as reactive current, power factor, compensation current, etc.

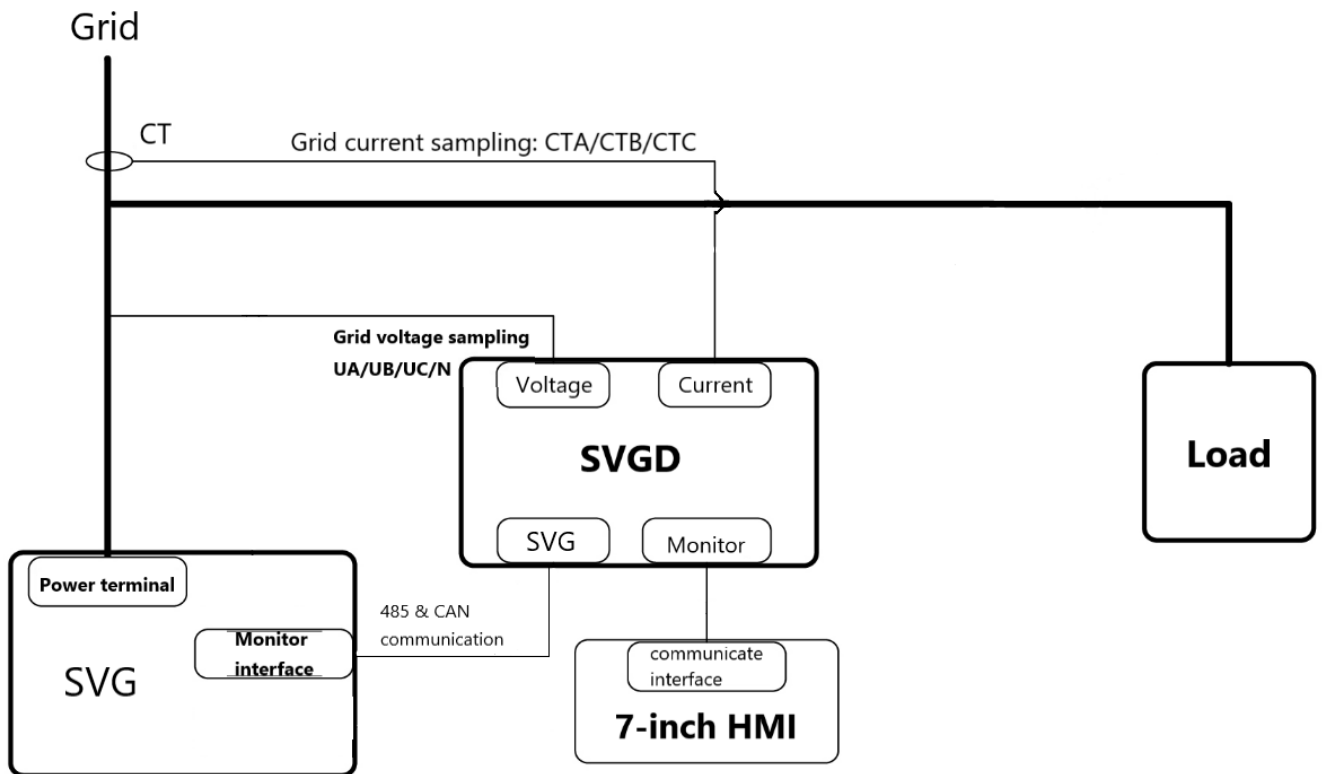

Figure 4.1 SVG + SVGD scheme principal and wiring diagram

When using multiple SVG and the SVGD control board, user need to connect the 485 and CAN communication cables in parallel between the SVG. The wiring diagram is shown in figure 4.2.

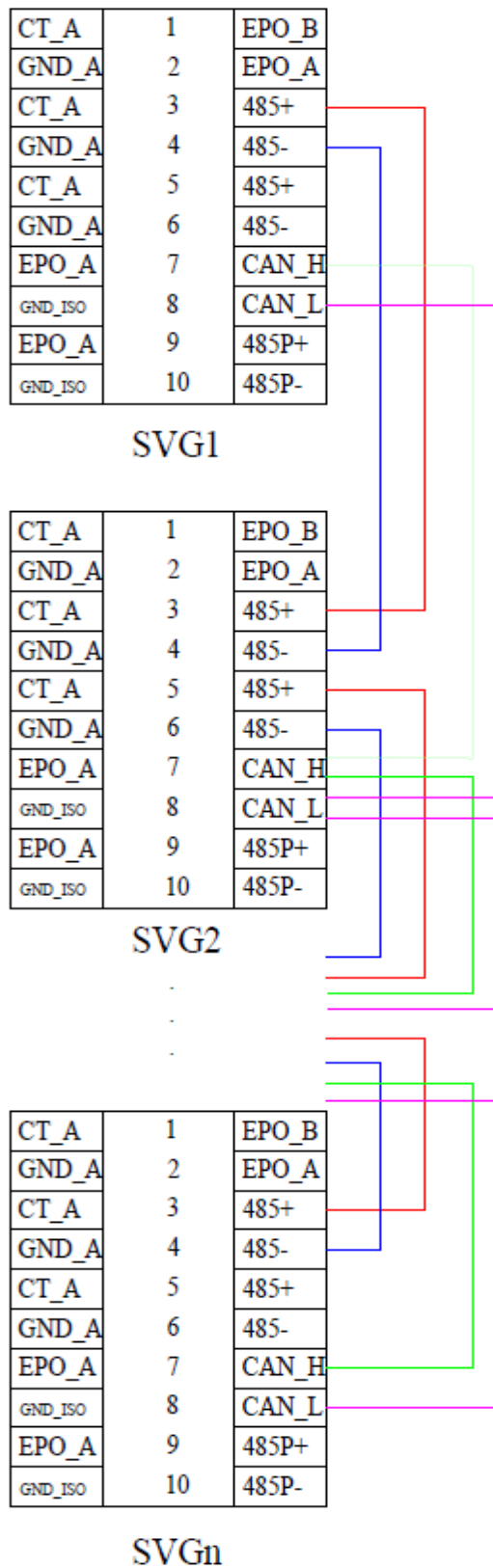

Figure 4.2 Multiple SVG wiring diagram

4.2 Parameter setting

When using SVGD with 7-inch central monitor, user need to enable the SVGD mode of the 7-inch HMI first.

- Use password '654321' to enter the setting of the 7-inch HMI.
- Click 'PREFER.', click page down, set the parameter 'SVGD module' to Enable.

