

LS DB unit LSLV-DBU Series



Safety Instructions

- Read this manual carefully before installing, wiring, operating, servicing or inspecting this equipment.
- Keep this manual within easy reach for quick reference.



- Headquarter**
LS-ro 127(Hogye-dong) Dongan-gu, Anyang-si, Gyeonggi-Do, 14119, Korea
- Seoul Office**
LS Yongsan Tower, 92, Hangang-daero, Yongsan-gu, Seoul, 04386, Korea
Tel: 82-2-2034-4033, 4888, 4703 Fax: 82-2-2034-4588
E-mail: automation@lselectric.co.kr
- Overseas Subsidiaries**
 - LS ELECTRIC Japan Co., Ltd. (Tokyo, Japan)**
Tel: 81-3-6268-8241 E-Mail: jschuna@lselectric.biz
 - LS ELECTRIC (Dalian) Co., Ltd. (Dalian, China)**
Tel: 86-411-8730-6495 E-Mail: jheo@lselectric.com.cn
 - LS ELECTRIC (Wuxi) Co., Ltd. (Wuxi, China)**
Tel: 86-510-6851-6666 E-Mail: sblee@lselectric.co.kr
 - LS ELECTRIC Vietnam Co., Ltd.**
Tel: 84-93-631-4099 E-Mail: jhchoi4@lselectric.biz (Hanoi)
Tel: 84-28-3823-7890 E-Mail: sjbaik@lselectric.biz (Hoachiminh)
 - LS ELECTRIC Middle East FZE (Dubai, U.A.E.)**
Tel: 971-4-886-5360 E-Mail: salesme@lselectric.biz
 - LS ELECTRIC Europe B.V. (Hoofddorf, Netherlands)**
Tel: 31-20-654-1424 E-Mail: europartner@lselectric.biz
 - LS ELECTRIC America Inc. (Chicago, USA)**
Tel: 1-800-891-2941 E-Mail: sales.us@lselectricamerica.com
- Overseas Branches**
 - LS ELECTRIC Tokyo Office (Japan)**
Tel: 81-3-6268-8241 E-Mail: jschuna@lselectric.biz
 - LS ELECTRIC Beijing Office (China)**
Tel: 86-10-5095-1631 E-Mail: khpaek@lselectric.com.cn
 - LS ELECTRIC Shanghai Office (China)**
Tel: 86-21-5237-9977 E-Mail: tsjun@lselectric.com.cn
 - LS ELECTRIC Guangzhou Office (China)**
Tel: 86-20-3818-2883 E-Mail: chenxs@lselectric.com.cn
 - LS ELECTRIC Chengdu Office (China)**
Tel: 86-28-8670-3201 E-Mail: yangcf@lselectric.com.cn
 - LS ELECTRIC Qingdao Office (China)**
Tel: 86-532-8501-2065 E-Mail: wangzy@lselectric.com.cn
 - LS ELECTRIC Nanjing Office (China)**
Tel: 86-25-8467-0005 E-Mail: ylong@lselectric.com.cn
 - LS ELECTRIC Bangkok Office (Thailand)**
Tel: 66-90-950-9683 E-Mail: sljeet@lselectric.biz
 - LS ELECTRIC Jakarta Office (Indonesia)**
Tel: 62-21-2933-7614 E-Mail: dich@lselectric.biz
 - LS ELECTRIC Moscow Office (Russia)**
Tel: 7-499-682-6130 E-Mail: jdpark1@lselectric.biz
 - LS ELECTRIC America Western Office (Irvine, USA)**
Tel: 1-949-333-3140 E-Mail: ywyun@lselectricamerica.com

Before using the product...

First, thank you for purchasing the DB unit of LS ELECTRIC. This manual describes how to use the unit and precautions. Incorrect use may result in damage to the product or significant decrease in the service life. For the sake of your safety and effective operation, please read this manual thoroughly before using the product.

Safety Precautions

- WARNING** This symbol indicates the possibility of serious injury or death if some applicable instruction is violated
 - CAUTION** This symbol indicates the possibility of slight injury or damage to products if some applicable instruction is violated
- There is a possibility that the contents described in "Caution" can also lead to a serious accident depending on the situation, so fully understand the description of all the items before use.

Instructions for safe use

1. To prevent electric shock



- Do not open the cover when the power is applied.
- Do not turn the power on with the cover open. It is dangerous since the high voltage terminals are exposed.
- Do not remove the cover except for periodic inspections or wiring, even if the input power is not applied. Do not touch the terminals of the DB unit in energized state of the inverter even if the inverter has stopped. Otherwise, you may get an electric shock.
- Always wait at least 10 minutes after turning the input power off and check the power with a tester before wiring or regular inspection.
- Inspection or wiring must be performed only by a qualified technician.

2. To prevent fire



- The DB unit or resistor should be installed on a non-combustible material. Installing on combustible materials or installed close to combustible material may cause fire.
- Shut down the input power to the inverter when failure occurs to the inverter or the DB unit. Otherwise, it could result in a fire due to overcurrent.

3. To prevent damage



- Be sure to follow the specified wiring method and wiring standard described in the manual.
- Incorrect terminal wiring could result in the inverter and the DBU damage.
- Reversing the polarity (+/-) of the terminals could damage the DB unit and the inverter.
- Do not touch the DB unit while the input power is applied or for minutes after the power is cut out. Do not touch the inverter body, DB unit, and braking resistor since they become very hot.

4. General Precautions



- Please carry the product in the correct way, depending on the weight of the product. Otherwise, DB unit damage may result.
- Be sure to follow the installation directions exactly as written.
- Do not allow any other foreign materials such as screws, metal material, water and oil into the DB unit.
- Do not perform megger test (measuring insulation resistor) for the DB unit.

5. Disposal



- Handle the unit as an industrial waste when disposing of it.

1. Model Name

- DB unit model name
EX) LSLV0220DBU - 4LN
LSLV : Model name (for LS low-voltage inverter)
0220 : DB unit capacity (e.g.: 0220 ▶ 22kW)
DBU : System name (DB unit)
4 : Input voltage (AC opening voltage, 2:220Vrms, 4: 380 - 440Vrms)
L : %ED (Duty factor, L: 10%ED)
N : Enclosure rating (N: Not rated enclosures)
- Manufacturer, date of manufacture, and production lot are written in the S/N.
EX) 15032000001
150320 : Date of manufacture (e.g. March 20th, 2015)
00001 : Product Serial Number
Barcode : Same as the serial number

2. Standard specifications

220V series

Model Name (LSLV□□□□DBU-2LN)	0150	0220	0370	0750	
The maximum DC input voltage	Maximum DC 400V for 220V series				
Applicable inverter capacity [kW]	15	22	37	75	
Rated Motor Capacity [kW]	15	22	37	75	
Damping Resistance	Resistance capacity (seconds operation, based on the operating voltage DC 380V)	Duty factor	Resistance Capacity		
		5%ED	2[kW]	3[kW]	5[kW]
	10%ED	4[kW]	6[kW]	10[kW]	20[kW]
Used minimum resistance	8[Ω]	5[Ω]	3[Ω]	1.5[Ω]	
Braking operation voltages	DC 380V (partly adjustable)				
Average Braking Torque	150% Braking Torque				

440V series

Model Name (LSLV□□□□DBU-4LN)	0150	0220	0370	0750	
The maximum DC input voltage	Maximum DC 800V for 440V series				
Applicable inverter capacity [kW]	15	22	37	75	
Rated Motor Capacity [kW]	15	22	37	75	
Damping Resistance	Resistance capacity (seconds operation, based on the operating voltage DC 380V)	Duty factor	Resistance Capacity		
		5%ED	2[kW]	3[kW]	5[kW]
	10%ED	4[kW]	6[kW]	10[kW]	20[kW]
Used minimum resistance	30[Ω]	20[Ω]	12[Ω]	6[Ω]	
Braking operation voltages	DC 760V (partly adjustable)				
Average Braking Torque	150% Braking Torque				

If overvoltage alarm occurs due to deceleration time settings of the inverter, please consult with us since it may require change of resistance value.

Common Specifications

Item	Specifications
Terminal	Alarm relay Output signal 250VAC 1A or less, 30VDC 1A or less / N.O. / N.C.
Protection	Cooling pin overheating Protects by detecting overheat with a built-in thermistor.
	Overcurrent Protects when the overcurrent occurs.
	Cooling system Natural cooling
Operating Environment	Installation location Indoor (without corrosive gas, flammable gas, oil mist, or dust)
	Ambient and Storage temperature -10 - +40℃(Ambient temperature), -20 - +65℃ (Storage temperature)
	Ambient humidity Relative humidity 90% RH or below (no dew condensation)
	Altitude 1,000m or less
	Vibration 5.9m/s ² (0.6G) or less

Note) The electric motor capacity is based on 4-pole. If it not a 4-pole, please contact us.

3. Installation of the Unit

- Never remove the cover and touch the inside of the unit while the power is on or in operation. There are sections in the unit that are charged with high voltages. Always wait at least 10 minutes after turning the input power off before starting inspections.
- Make sure that the ambient humidity (90% RH or below) and the ambient temperature (-10℃ to 40℃) are in the right range. High and low humidity may cause problems with the insulation and temperature exceeding 40℃ can shorten the life of the electrolytic capacitor.
- Be sure to install the unit vertically to facilitate cooling. 5cm or wider spaces on the left and right side of the unit 10cm or wider spaces on the top and bottom of the unit have to be secured.
- Do not install the unit in a location where excessive vibration and subject to direct sunlight. Excessive vibration may cause loose screws and connect and it may cause malfunction.
- Install the unit in a location where free from dust and corrosive gas. Dust and corrosive gases can cause poor contact and result in malfunction.

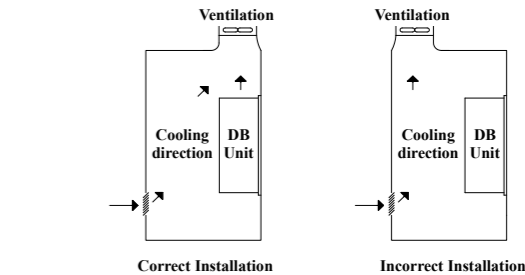
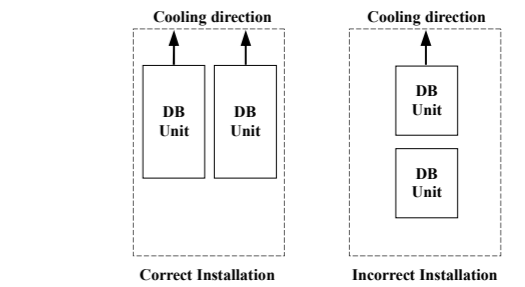
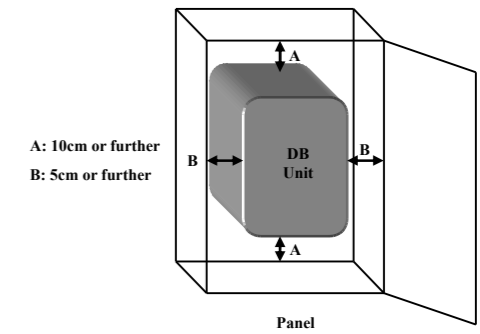

4. Terminal Block Description

Main circuit terminal block

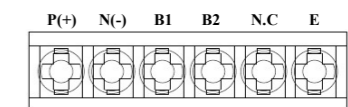

Terminal Symbols	Description
P(+)	Connecting DC Voltage
N(-)	Connected with the DC power of the inverter
B1	Connecting external resistor
B2	Used to connect external resistors
N.C	Not used
E	Ground connection
	Used to connect external ground

Alarm Output Terminal

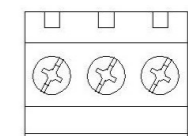

30CT 30BT 30AT

Terminal Symbols	Functions	Specifications
30AT	Alarm A contact output terminal	250VAC/1A 30VDC/1A
30BT	Alarm B contact output terminal	
30CT	Common terminal for A and B contact	

5. Terminal Block Connection Method

- ▶ For connecting inverter, DB unit, and braking resistor.

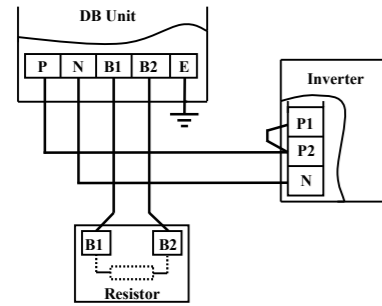

- ▶ Wiring in combination with a DC reactor for power factor improvement

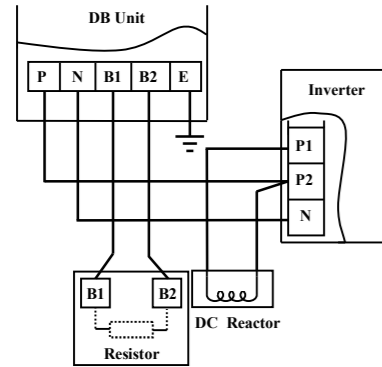

6. Precautions for wiring

- ▶ Connect the DC link circuit terminals P (+) and N (-) of the inverter to the terminals P (+) and N (-) of the DB unit. Do not connect output terminals (B1, B2) of the DB unit to the input terminal P (+), N (-). Otherwise, DB unit failure may result.

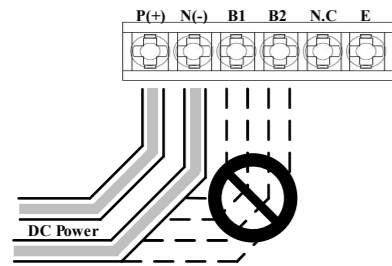

- ▶ Be careful not to leave any foreign matter inside of the DB unit after wiring.
- ▶ Use the shield or twisted wire for the wires of the alarm output terminal and do not wire in the same duct as the wiring of the main circuit.

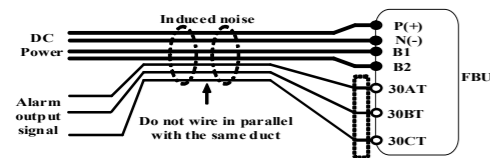

7. Basic Wiring Diagram

- ▶ Arrange the wires between the inverter and the DB unit, the DB unit and the braking resistor to be twisted.
- ▶ In case of using two DB units, arrange the wire rout so that the wire length is less than 2m and to be twisted.
- ▶ Arrange the wire length between the inverter and the DB unit, the DB unit and the braking resistor is less than 5m.
- ▶ Ensure that the terminal for grounding DB unit and inverter is grounded.

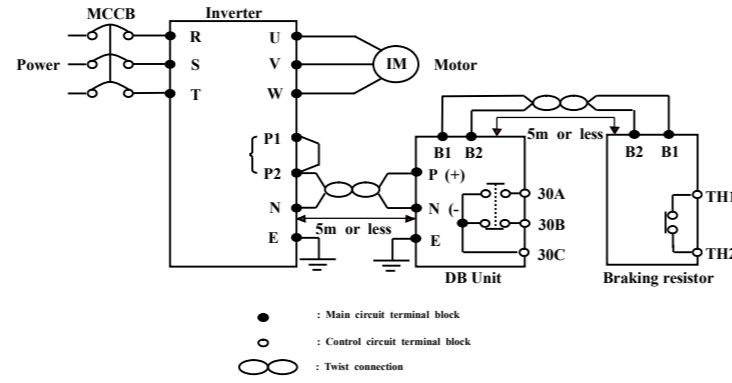

- ▶ Screws and wire size for main circuit terminal
- ▶ When connecting input power (P (+), N (-)) and resistance (B1, B2), if it is not correctly wired to the high-voltage circuit, the DB unit could be damaged or the operator could be in danger. Be careful not to deviate from the accepted specification.

DB model name	Terminal Screw	Tightening Torque	Wire size	Pressure Terminal
LSLV0150-2LN	M4	1.4 [N·M]	4mm ² (10AWG)	4mm ² , 4Φ Hole
LSLV0220-2LN				
LSLV0370-2LN				
LSLV0750-2LN				
LSLV0150-4LN				
LSLV0220-4LN	2.5mm ² (12AWG)	2.5mm ² , 4Φ Hole		
LSLV0370-4LN				
LSLV0750-4LN				

- ▶ Screws and wire size for control circuit terminal
- ▶ Wires for alarm output relay terminal block use stranded wire between 26 AWG and 18 AWG.
- ▶ If it is not wired correctly, malfunction or damage may result or operator could be in danger. Be careful not to deviate from the accepted specification.

DB model name	Terminal Screw	Tightening Torque	Wire size	Pressure Terminal
LSLV0150-2LN	M2.5	0.5 [N·M]	AWG 20 - 18	BLADE / BAR / PIN Type
LSLV0220-2LN				
LSLV0370-2LN				
LSLV0750-2LN				
LSLV0150-4LN				
LSLV0220-4LN				
LSLV0370-4LN				
LSLV0750-4LN				

8. Operation description

- ▶ When power is established, it will operate automatically.

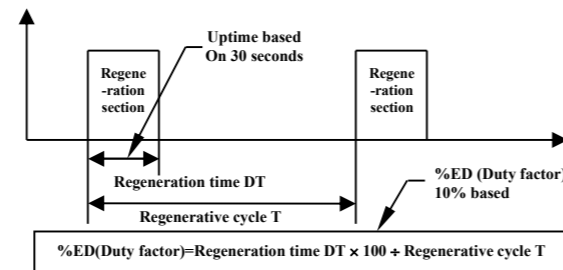

- ▶ Duty factor displays percentage of actual braking operation for the cycle that operating the DB unit.
- ▶ Since the duty factor generates the overload fault when it exceeds the set value, it should be set according to the application.
- ▶ The uptime is the time that an action can be performed continuously. Since when it exceeds the set time, it also cause overload malfunction so it should be set carefully.

9. Operating Voltage Setting

- ▶ The operating voltage is determined by the jumper socket position of the CN2. You can change the operating voltage by changing the position of the jumper socket.
- ▶ For the 200V type, you can set the operating voltage of 340V / 360V / 380V.
- ▶ For the 400V type, you can set the operating voltage of 680V / 720V / 760V.
- ▶ For the 200V type, default position of the socket is 380V.
- ▶ For the 400V type, default position of the socket is 760V.

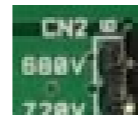

10. Display Description

- ▶ LED indications on the front panel



- ▶ LED indication examples

Indications	Description
	LED is on.
	LED is off.

- ▶ Display Status

POWER	ALARM	Status	Description
		Power Off	Power is not applied to the DBU.
		Power Ready	The power is applied to the BDU.
		Alarm State	Malfunction has occurred due to overcurrent. PIN has overheated.

11. Maintenance and Inspection

- ▶ DB unit is industrial electronics that adopted state-of-the-art semiconductor elements. Effects of the environment such as temperature, humidity, and vibration and the aging of components may cause a malfunction. To prevent malfunction and ensure long-term reliability, daily inspection is required.
- ▶ When checking the inside of the DB unit, since the smoothing condenser is maintained in high-voltage state after the power has been turned off, make sure to check that the DC voltage between the terminals P (+) and N (-) is 30V or less before starting the inspection.
- ▶ Daily inspection
 - Is there any abnormality in the installation location?
 - Is there vibration or abnormal sound?
 - Is there any indication of overheating or discoloration?
- ▶ Periodical inspection
 - Are there any loose screws or connectors? : In the severe vibration, screws and bolts might be loosened. Check them correctly and tighten or replace them.
 - Is there any corrosion or damage to the conductors or insulators?
 - Measuring the insulation resistance
 - Check and replace a smoothing condenser, and relay.
 - Is there foreign matter on the PCB of the DB unit?
 - Is there any abnormality on contacts of the various connectors in the PCB?

- ▶ Life of the main parts and maintenance

Part name	Standard period for replacement	Replacement method and others
Relay parts	-	Exchange for a new part (Determined after checking)
PCB Board	-	Exchange for a new circuit board (Determined after checking)
Electrolytic capacitor on the PCB	5 years	Exchange for a new circuit board (Determined after checking)

- ▶ Since the life of the main components was determined based of the case of continuous operation at the rated load, it may differ depending on the environment and using conditions.

12. Failure Causes and Countermeasures

- ▶ If a problem occurs while using the product and the brake unit is not operable, deal with the problem after checking the cause by referring to the troubleshooting methods below. If problem occurs other than the cases listed below; a failure of the DB unit is found, components are broken. Please contact your dealer or sales representatives.

Protective Function	Possible Cause	Countermeasures
Overcurrent	1) The resistance connected to the DB unit is too small. 2) Output short circuit of the DB unit	1) Increase the using resistance of the DB unit. 2) Remove short circuit by checking the resistance connection.
PIN Overheating	1) Load is larger than rating. 2) Cooling system has faults. 3) Ambient temperature high. 4) Incorrect DB unit capacity selected.	1) Check if the load is correctly selected according to the %ED. 2) Check for alien substances in the heat sink. 3) Keep ambient temperature under 40 °C. 4) Select correct DB unit capacity.
Other faults	1) Internal board has faults. 2) Electronic component has damages.	1) Shut down all the power. 2) Contact your dealer or service center.

13. Dimensions

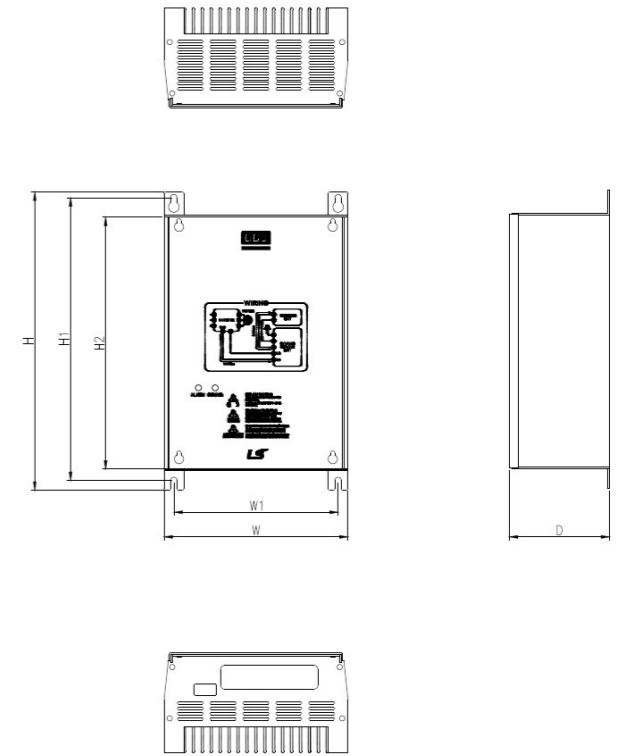

Use d Voltage (V)	Capa city (kW)	Product Size (mm)				Attachment location (mm)		Weigh t (kg)	Bolt size (φ)	
		W	H	H2	D	W1	H1			
220	15	140	227.4	192	76.4	125	215.4	1.50	M4	
	22									1.55
	37									1.57
440	75	1.84								
	15	1.53								
	22	1.55								
37	1.56									
75	1.85									