

The right choice for the ultimate yield!

LS ELECTRIC strives to maximize your profits in gratitude for choosing us as your partner.

DB Unit

SV-DB series

User's Manual



Safety Instructions

- Read this manual carefully before installing, wiring, operating, servicing or inspecting this equipment.
- Keep this manual within easy reach for quick reference.



LS ELECTRIC Co., Ltd.

■ **Headquarter**
 LS-ro 127(Hoge-dong) Dangan-gu, Anyang-si, Gyeonggi-Do, 14119, Korea
 ■ **Seoul Office**
 LS Yongan Tower, 92, Hangeong-daem, Yongsan-gu, Seoul, 04386, Korea
 Tel: 82-2-2034-4033, 4088, 4703 Fax: 82-2-2034-4588
 E-mail: automation@lselectric.co.kr

■ **Overseas Subsidiaries**

- LS ELECTRIC Japan Co., Ltd. (Tokyo, Japan)
 Tel: 81-3-6268-8241 E-Mail: jschuna@lselectric.biz
- LS ELECTRIC (Taiwan) Co., Ltd. (Taipei, China)
 Tel: 86-411-8730-6495 E-Mail: jrho@lselectric.com.cn
- LS ELECTRIC (Wuxi) Co., Ltd. (Wuxi, China)
 Tel: 86-510-6851-6666 E-Mail: sbhee@lselectric.co.kr
- LS ELECTRIC Vietnam Co., Ltd.
 Tel: 84-93-631-4099 E-Mail: jhchoi@lselectric.biz (Hanoi)
 Tel: 84-28-3823-7990 E-Mail: gba@lselectric.biz (Ho Chi Minh)
- LS ELECTRIC Middle East FZE (Dubai, U.A.E.)
 Tel: 971-4-886-5380 E-Mail: salesme@lselectric.biz
- LS ELECTRIC Europe B.V. (Hooftdord, Netherlands)
 Tel: 31-20-654-1424 E-Mail: europartner@lselectric.biz
- LS ELECTRIC America Inc. (Chicago, USA)
 Tel: 1-800-891-2941 E-Mail: sales.us@lselectricamerica.com

■ **Overseas Branches**

- LS ELECTRIC Tokyo Office (Japan)
 Tel: 81-3-6268-8241 E-Mail: jschuna@lselectric.biz
- LS ELECTRIC Beijing Office (China)
 Tel: 86-10-5295-1631 E-Mail: kbpark@lselectric.com.cn
- LS ELECTRIC Shanghai Office (China)
 Tel: 86-21-5237-9977 E-Mail: tpsun@lselectric.com.cn
- LS ELECTRIC Guangzhou Office (China)
 Tel: 86-20-3819-2883 E-Mail: chenw@lselectric.com.cn
- LS ELECTRIC Chengde Office (China)
 Tel: 86-29-8679-3291 E-Mail: yanggf@lselectric.com.cn
- LS ELECTRIC Qingdao Office (China)
 Tel: 86-532-8501-2085 E-Mail: wangty@lselectric.com.cn
- LS ELECTRIC Nanjing Office (China)
 Tel: 86-25-8467-0025 E-Mail: ylong@lselectric.com.cn
- LS ELECTRIC Bangkok Office (Thailand)
 Tel: 66-90-950-9033 E-Mail: gba@lselectric.biz
- LS ELECTRIC Jakarta Office (Indonesia)
 Tel: 62-21-2933-7614 E-Mail: doh@lselectric.biz
- LS ELECTRIC Moscow Office (Russia)
 Tel: 7-499-682-6130 E-Mail: jdpark@lselectric.biz
- LS ELECTRIC America Western Office (Irvine, USA)
 Tel: 1-949-333-3140 E-Mail: yeoyun@lselectricamerica.com

10310001657



Disclaimer of Liability
 LS ELECTRIC has reviewed the information in this publication to ensure consistency with the hardware and software described. However, LS ELECTRIC cannot guarantee full consistency nor be responsible for any damages or compensation, since variance cannot be precluded entirely. Please check again the version of this publication before you use the product.

© LS ELECTRIC Co., Ltd 2020 All Right Reserved.

SV-DB / 2020.05

Before handling the product

This manual describes the safety instructions that must be followed when installing, operating, and servicing. Read this manual completely before installing. The unit contains high voltage that can cause electric shock resulting in personal injury or loss of life.

Safety Instructions

- Always follow safety instructions to prevent accidents and potential hazards from occurring.
- In this manual, safety messages are classified as follows :

WARNING Improper operation may result in serious personal injury or death.

CAUTION Improper operation may result in slight to medium personal injury or property damage.

- Throughout this manual we use the following two illustrations to make you aware of safety considerations

! Identifies potential hazards under certain conditions. Read the message and follow the instructions carefully.

⚡ Identifies shock hazards under certain conditions. Particular attention should be directed because dangerous voltage may be present.

WARNING

- **Do not remove the cover while power is applied or the unit is in operation.**
 Otherwise electric shock could occur.
- **Do not run the DB unit with the front cover removed.**
 Failure to comply could result in electric shock due to high voltage terminals or charged capacitor exposure.
- **Do not remove the cover except for periodic inspections or wiring, even if the input power is not applied.**
 Otherwise, you may access the charged circuits and get an electric shock.
- **Wiring and periodic inspections should be performed at least 10 minutes after disconnecting the input power and after checking the DC link voltage is discharged with a meter (below DC 30V).**
 Otherwise, you may get an electric shock.
- **Operate the switches with dry hands.**
 Otherwise, you may get an electric shock.
- **Do not use the cable when its insulating tube is damaged.**
 Otherwise, you may get an electric shock.
- **Do not subject the cables to scratches, excessive stress, heavy loads or pinching.**
 Otherwise, you may get an electric shock.

CAUTION

- **Install the DB unit on a non-flammable surface. Do not place flammable material nearby.**
 Otherwise, fire could occur.
- **Disconnect the input power if the inverter or DB unit gets damaged.**
 Otherwise, it could result in a secondary accident and fire.
- **Do not connect the braking resistor directly to the DC terminal (P/B1, N) of the DB unit.**
 Otherwise, fire could occur.
- **Do not touch DBU, inverter and the resistor right after the power is turn off.**
 The resistor is still hot.
- **Do not allow lint, paper, wood chips, dust, metallic chips or other foreign matter into the DB unit.**
 Otherwise, fire or accident could occur.
- **Do not apply power to a damaged inverter or to DBU with missing parts even if the installation is complete.**
 Otherwise, electric shock or fire could occur.

1. Nomenclature

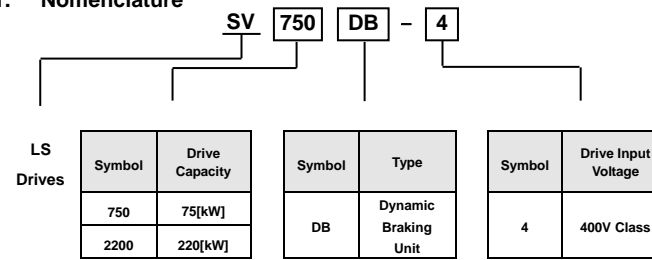

2. Specifications

Model Name	SV750DB-4	SV2200DB-4			
Max. DC Input Volt.	DC 800V (400V Class)				
Applicable Drive Capacity	75[kW]	220[kW]			
Braking Resistor	Motor Capacity	75[kW]	220[kW]		
	Resistor capacity for %ED(Reference 100sec)	%ED	Resistor capacity[kW]	%ED	Resistor capacity[kW]
		5	10	5	30
		10	20	10	60
		20	40	20	120
		50	100	50	300
C.O	Over 200kW	C.O	Over 600kW		
Resistor	6Ω	2Ω			
DB Units Operating Voltage	DC 760V ± 1%				
Average Braking Torque	150%				
Enable Duty	100% ED				
Output Signal	Fault output contact, Slave control signal				
Protection (Trip)	Heat sink Over-heat , Over-current				
Environmental Conditions	Ambient Temperature	-10℃ ~ 40℃			
	Humidity	Under 90% RH (Non-condensing)			
	Altitude	Under 1,000m above sea level			
	Cooling	Self-cooling			

3. Installation

- **Environmental Conditions**
 - 1) Do not mount the unit in direct sunlight. Isolate the unit from excessive vibration.
 - 2) Protect the unit from moisture, dust, metallic particles, corrosive gases and liquids. Install the units on a non-flammable material and as smooth as possible.
 - 3) In case of installing many units in a panel, consider the air flows for power dissipation. (see below figures for proper installation)

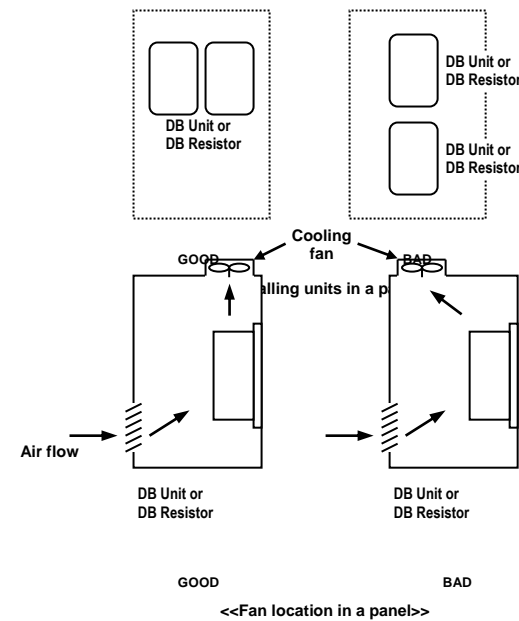

■ Mounting

The units must be mounted vertically with sufficient room (horizontally and vertically) from adjacent equipment.

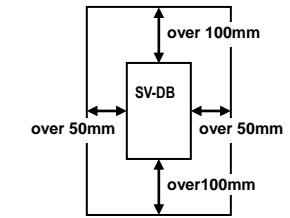

4. Terminal Configuration

1) Power Terminals

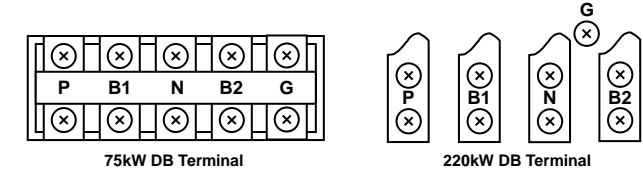

Terminal	Function
P	DC (+) input. Connect to "P2" terminal of drive
B1	Connect to "B1" terminal of braking resistor
N	DC (-) input. Connect to "N" terminal of drive
B2	Connect to B2 braking resistor
G	Ground

2) Control Terminals

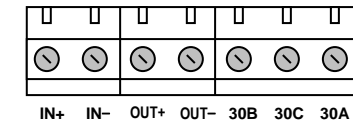

Terminal	Function
IN+	Slave turn on signal input (when "Slave Mode" selected)
IN-	Slave turn on signal input (when "Slave Mode" selected)
OUT+	Slave turn on signal output (when "Master Mode" selected)
OUT-	Slave turn on signal output (when "Master Mode" selected)
30A	Fault signal output
30B	30A : Normal open contact
30C	30B : Normal close contact, 30C : Common terminal

(Refer to sec. 7 for details of Master/Slave Operation)

5. Terminal Wiring

- The SV-DB series have two kinds of power terminal configurations. Make sure the wiring according to drive capacity.

1) Wiring Drive, DB unit and DB resistor

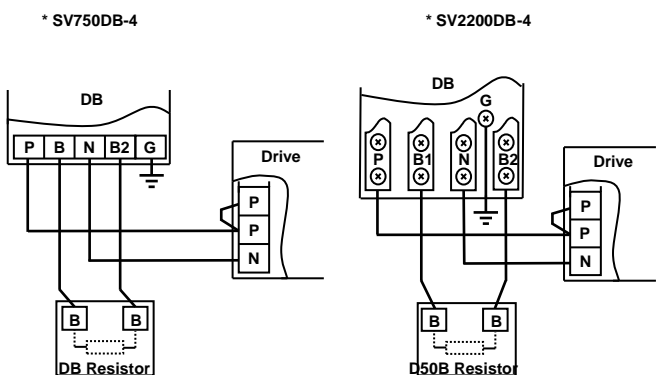

2) Wiring Drive, DB unit and DB resistor and DC reactor for SV750DB-4

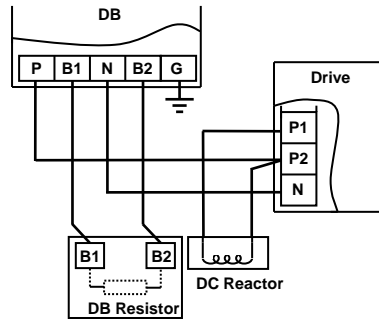

3) Wiring Drive, DB unit, DB resistor and DC reactor for SV2200DB-4

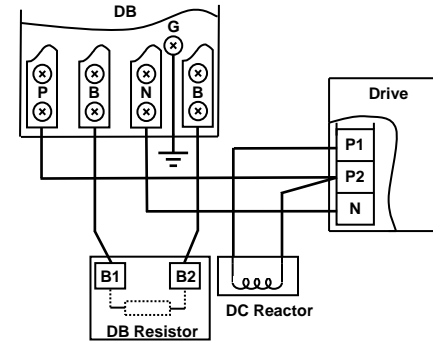

- Use twist wire shorter than 5m between drive, DB unit and DB resistor.
- In case of master/slave operation, the control wire should be shorter than 2m with twist wire.
- Be sure to earth terminal "G" of drive and DB unit.
- Wire Size:

DB units	%ED	Wire size (AWG)
SV750DB-4	5~20%ED	22 mm^2 (AWG 4)
	50%ED	38 mm^2 (AWG 2)
	Continuous Operation	60 mm^2 (AWG 1/0)
SV2200DB-4	5~20%ED	60 mm^2 (AWG 1/0)
	50%ED	70 mm^2 (AWG 2/0)
	Continuous Operation	100 mm^2 (AWG 4/0)

7. Master / Slave Operation

- 1) In case of parallel operation of two braking units, the one must be set at "Master" and the other at "Slave". (When one braking unit is operated it must be set at "Master" : Factory default – "Master")
- 2) How to set to Master (on PCB)
 - Set the "Select Switch S1" as below figure.



- 3) How to set to Slave (on PCB)
 - Set the "Select Switch S1" as below figure.



4) Connection between Master and Slave

- Connect "OUT+" terminal of Master to "IN+" terminal of Slave and "OUT-" terminal of Master to "IN-" terminal of Slave.

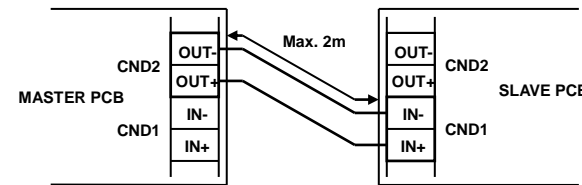

8. Combination of DB Units according to Drive Capacity

1) Combination of Braking Units

Drive Type	SV750iV5-4	SV2200iV5-4	SV2800/3150/3750iV5-4
Braking Unit	SV750DB-4	SV2200DB-4	SV2200DB-4 × 2 sets
Braking Resistor	6 Ω	2 Ω	2 Ω × 2 sets
Applicable Motor	75kW	220kW	280/315/375kW

- See below for the combination of DB Units and DB resistors.
- When using DB units above 220kW inverter contact LS ELECTRIC or your distributor.

2) Combination of 400V Class Units

- ▶ Drive Capacity: 75[kW]
- ▶ Drive Capacity: 220[kW]

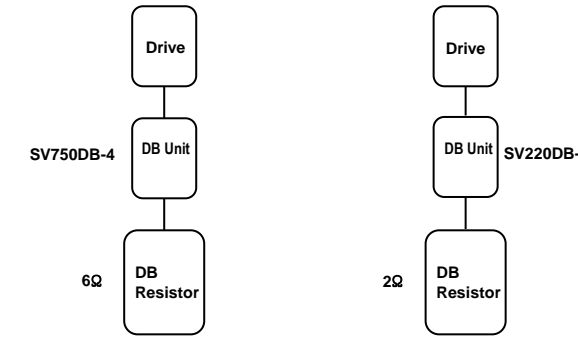

- ▶ Drive Capacity: 280[kW] ~ 375[kW]

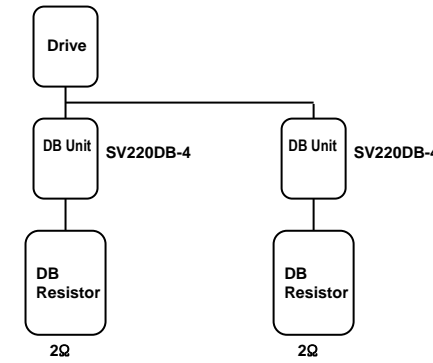

9. Display LED and Fault Reset

The DB Unit have four LEDs on the frontcover. The green LEDs display main power input and braking operation. The red LEDs display fault status of the unit.

Display	Function
POWER	This LED is turned on when the input power of the unit is introduced.
RUN	This LED is turned on when the unit is in the braking operation.
OHT	This LED is turned on and cut off (trip) the output when the heat sink of the unit is over heated.
OCT	This LED is turned on when an excessive current flows through the IGBT and the unit cut off the output to protect the unit
FOT	When IGBT fail, Fuse open and then cut the output and turn on the FOT LED.

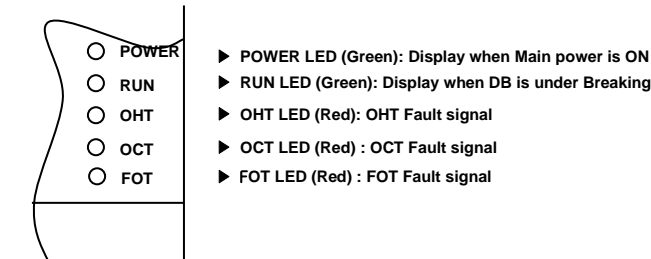

10. Dimensions

Applicable Model : SV750DB-4, SV2200DB-4

Units: [mm]

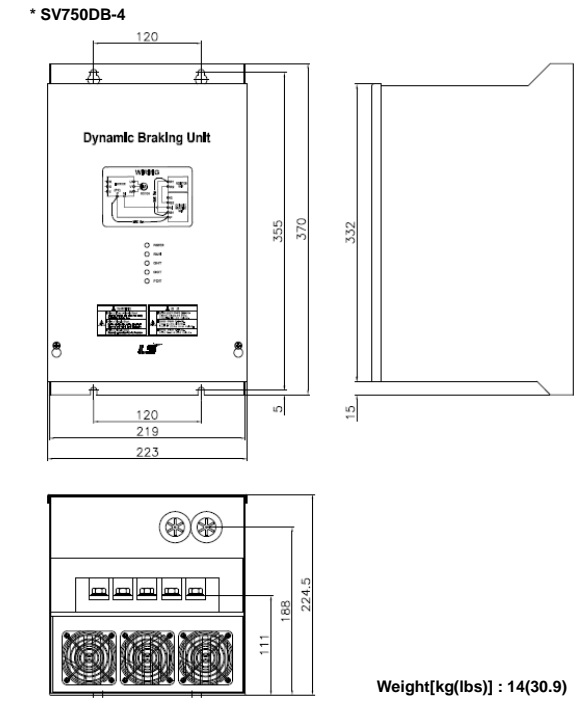

Weight[kg(lbs)] : 14(30.9)

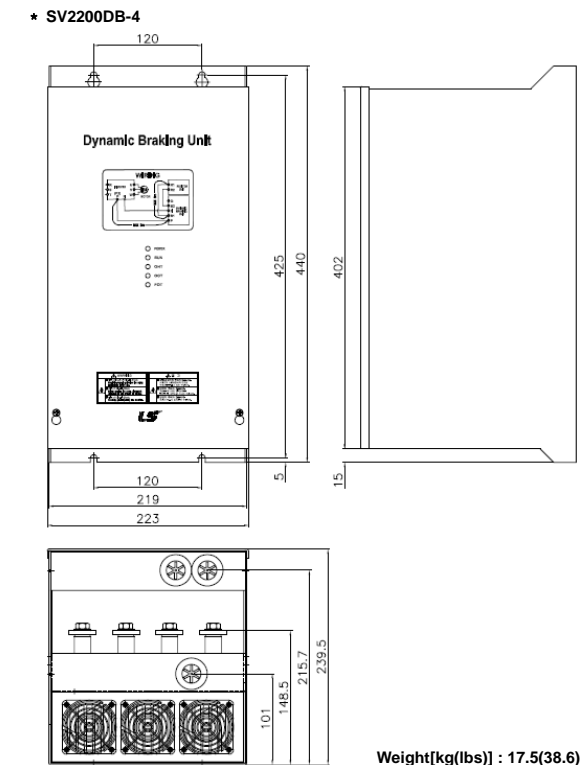

Weight[kg(lbs)] : 17.5(38.6)

6. Basic Wiring

1) Single Operation

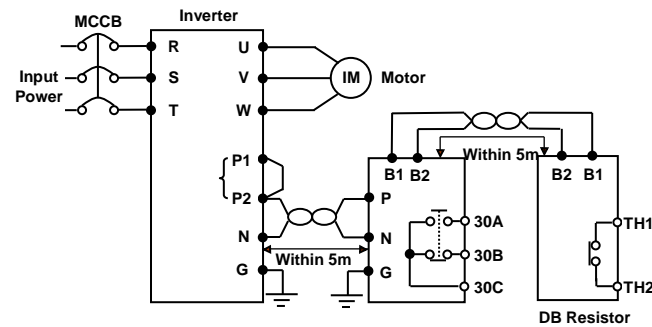

2) Master/Slave Operation

