



Emotron MSF 2.0 Softstarter



Instruction manual
English

Valid for the following softstarter models:
Emotron MSF 2.0

Emotron MSF 2.0

SOFTSTARTER

Instruction manual

Document number: 01-5924-01

Edition: r0

Date of release: 2012-03-01

© Copyright CG Drives & Automation Sweden AB 2011-2012

CG Drives & Automation Sweden AB retains the right to change specifications and illustrations in the text, without prior notification. The contents of this document may not be copied without the explicit permission of CG Drives & Automation Sweden AB.

Safety instructions

Safety

The softstarter should be installed in a cabinet or in an electrical control room.

- The device must be installed by trained personnel.
- Disconnect all power sources before servicing.
- Always use standard commercial fuses, slow blow e.g. gI, gG types, to protect the wiring and prevent short circuiting. To protect the thyristors against short-circuit currents, superfast semiconductor fuses can be used if preferred. The normal guarantee is valid even if superfast semiconductor fuses are not used.

Operating and maintenance personnel

1. Read the whole Instruction Manual before installing and putting the equipment into operation.
2. During all work (operation, maintenance, repairs, etc.) observe the switch-off procedures given in this instruction as well as any other operating instruction for the driven machine or system. See Emergency below.
3. The operator must avoid any working methods which reduce the safety of the device.
4. The operator must do what he can to ensure that no unauthorised person is working on the device.
5. The operator must immediately report any changes to the device which reduce its safety to the user.
6. The user must undertake all necessary measures to operate the device in perfect condition only.

Installation of spare parts

We expressly point out that any spare parts and accessories not supplied by us have also not been tested or approved by us.

Installing and/or using such products can have a negative effect on the characteristics designed for your device. The manufacturer is not liable for damage arising as a result of using non-original parts and accessories.

Emergency

You can switch the device off at any time with the mains switch connected before the softstarter (both motor and control supply voltage must be switched off).

Dismantling and scrapping

The enclosure of the softstarter is made of recyclable material such as aluminium, iron and plastic. Legal requirements for disposal and recycling of these materials must be complied with.

The softstarter contains a number of components demanding special treatment, such as thyristors for example. The circuit boards contain small amounts of tin and lead. Legal requirements for the disposal and recycling of these materials must be complied with.

General warnings



WARNING!

Make sure that all safety measures have been taken before starting the motor in order to avoid personal injury.



WARNING!

Never operate the softstarter with the front cover removed.



WARNING!

Make sure that all safety measures have been taken before switching on the power supply.

Content

Safety instructions	1	8. Functional description.....	43
Content.....	3	8.1 General settings.....	44
1. General information	5	8.2 Motor data	45
1.1 How to use the Instruction Manual.....	5	8.3 Motor protection.....	46
1.2 Integrated safety systems	5	8.4 Parameter set handling.....	51
1.3 Safety measures	5	8.5 Auto reset	52
1.4 Notes to the Instruction Manual	5	8.6 Serial communication.....	55
1.5 Type number.....	6	8.7 Operation settings.....	56
1.6 Transport and packing.....	6	8.8 Process protection	70
1.7 Unpacking MSF-310 and larger types	6	8.9 I/O settings.....	78
1.8 Glossary	7	8.10 View operation.....	93
2. Description.....	9	8.11 Alarm list.....	97
2.1 Background theory.....	9	8.12 Softstarter data	97
2.2 Reduced voltage starting.....	10	9. Protection and alarm	99
2.3 Other starting methods.....	12	9.1 Alarm codes.....	99
2.4 Use of softstarters with torque control	14	9.2 Alarm actions.....	99
3. Mounting.....	15	9.3 Reset.....	99
3.1 Installation of the softstarter in a cabinet.....	15	9.4 Alarm overview	100
4. Connections	19	10. Troubleshooting	103
4.1 Connecting mains and motor cables	20	10.1 Fault, cause and solution	103
4.2 Control Connection	24	11. Maintenance	107
4.3 Minimum wiring.....	25	11.1 Regular maintenance	107
4.4 Wiring examples.....	25	12. Options.....	109
5. How to get started.....	27	12.1 Serial communication	109
5.1 Checklist	27	12.2 Fieldbus systems.....	109
5.2 Applications	27	12.3 External control panel.....	109
5.3 Motor data	28	12.4 Terminal clamp.....	110
5.4 Start and stop.....	28	12.5 IT-net option.....	111
5.5 Setting the start command.....	29	13. Technical data.....	113
5.6 Viewing the motor current	29	13.1 Electrical specifications	113
5.7 Starting	29	13.2 General electrical specifications.....	118
6. Applications and functions selection	31	13.3 Fuses and power losses	119
6.1 Softstarter rating according to AC53a	31	13.4 Mechanical specifications including mechanical drawings	121
6.2 Softstarter rating according to AC53b.....	31	13.5 Derating at higher temperature	122
6.3 The Applications Rating List	32	13.6 Environmental conditions.....	122
6.4 The Application Functions List	34	13.7 Standards	122
6.5 Special conditions.....	36	13.8 Power- and signal connectors.	123
7. Operation of the softstarter.....	39	13.9 Semi-conductor fuses	124
7.1 General description of user interface.....	39	14. Set-up menu list	125
7.2 Control panel	39	Index	133
7.3 LED indication	40		
7.4 The menu structure.....	40		
7.5 The keys.....	40		
7.6 Control panel lock	41		
7.7 Overview of softstarter operation and parameter set-up.....	42		

1. General information

This manual describes the softstarter Emotron MSF 2.0.

1.1 How to use the Instruction Manual

This instruction manual tells you how to install and operate the softstarter Emotron MSF 2.0. Read the whole Instruction Manual before installing and putting the unit into operation.

Once you are familiar with the softstarter, you can operate it from the control panel by referring to chapter 5, page 27. This chapter describes all the functions and possible settings.

1.2 Integrated safety systems

The device is equipped with a protection system which reacts to:

- Over temperature
- Voltage unbalance
- Over- and under voltage
- Phase reversal
- Phase loss
- Motor overload protection thermal and PTC.
- Motor shaft power monitor, protecting machine or process maximum or minimum alarm.
- Starts per hour limitation

The softstarter is equipped with a connection for protective earth \perp (PE).

All MSF 2.0 softstarters are IP 20 enclosed types, except MSF-1000 and MSF-1400 which are delivered as open chassis IP00.

1.3 Safety measures

These instructions are a constituent part of the device and must be:

- Available to competent personnel at all times.
- Read prior to installation of the device.
- Observed with regard to safety, warnings and information given.

The tasks in these instructions are described so that they can be understood by people trained in electrical engineering. Such personnel must have appropriate tools and testing instruments available. Such personnel must have been trained in safe working methods.

The safety measures laid down in DIN standard VDE 0100 must be guaranteed.

The user must obtain any general and local operating permits and meet any requirements regarding:

- Personnel safety
- Product disposal
- Environmental protection

NOTE: The safety measures must remain in force at all times. Should questions or uncertainties arise, please contact your local sales outlet.

1.4 Notes to the Instruction Manual

NOTE: Additional information as an aid to avoiding problems.



CAUTION!

Failure to follow these instructions can result in malfunction or damage to the softstarter.



WARNING!

Failure to follow these instructions can result in serious injury to the user in addition to serious damage to the softstarter.

Important

For all enquiries and spare parts orders, please quote the correct name of the device and serial number to ensure that your inquiry or order is dealt with correctly and swiftly.

1.5 Type number

Fig. 1, page 6 gives an example of the type code number used for an Emotron MSF Softstarter. With this code number the exact type of the softstarter can be determined. This identification will be required for type specific information when mounting and installing. The code number is located on the product label, on the front of the unit.

MSF	-017	525	2	C	V	N	I		U
1	2	3	4	5	6	7	8	9	10 11

Fig. 1 Type number.

Table 1

Position	Configuration parameter	Description
1	Softstarter type	MSF 2.0 type, Fixed
2	Motor current	017-1400 A
3	Mains supply voltage	525=200-525 V 690=200-690 V
4	Control supply voltage	2=100-240 V 5=380-500 V
5	Control panel option	C=Standard, no external control panel H=External control panel
6	Coated boards option	-=No coated boards V=Coated boards
7	Communication option	N=No COM included S=RS232/485 included D=DeviceNet included P=Profibus included
8	IT-net option	-=Standard I=Special connection for IT earthing system
9	Additional options	U= UL/cUL approved
10		
11		

NOTE: With the IT-net option outer measures have to be taken to fulfil EMC regulations according to section 13.7, page 122.

1.6 Transport and packing

The device is packed in a carton or plywood box for delivery. The outer packaging can be recycled. The devices are carefully checked and packed before dispatch, but transport damage cannot be ruled out.

Check on receipt

Check that the goods are complete as listed on the delivery note, see type no. etc. on the rating plate.

Is the packaging damaged?

Check the goods for damage (visual check).

If you have cause for complaint

If the goods have been damaged during transport:

- Contact the transport company or the supplier immediately.
- Keep the packaging (for inspection by the transport company or for returning the device).

Packaging for returning the device

Pack the device so that it will resist shock and impact.

Intermediate storage

After delivery or after it has been dismantled, the device can be stored before further use in a dry room.

1.7 Unpacking MSF-310 and larger types

The MSF 2.0 softstarter is attached to the plywood box/ loading stool by screws, and the softstarter must be unpacked as follows:

1. Open only the securing plates at the bottom of the box (bend downwards). Then lift up the box from the loading stool, both top and sides in one piece.
2. Loosen the three (3) screws on the front cover of the softstarter unit, down by the lower logo.
3. Push up the front cover about 20 mm so that the front cover can be removed.
4. Remove the two (2) mounting screws at the bottom of the softstarter.
5. Lift up the softstarter unit at the bottom about 10 mm and then push backwards about 20 mm so that the softstarter can be removed from the mounting hooks* at the top. The hooks are placed under the bottom plate and cannot be removed until the softstarter is pulled out.
6. Loosen the two screws (2) for the mounting hooks and remove the hooks.
7. The hooks are used as an upper support for mounting the softstarter.

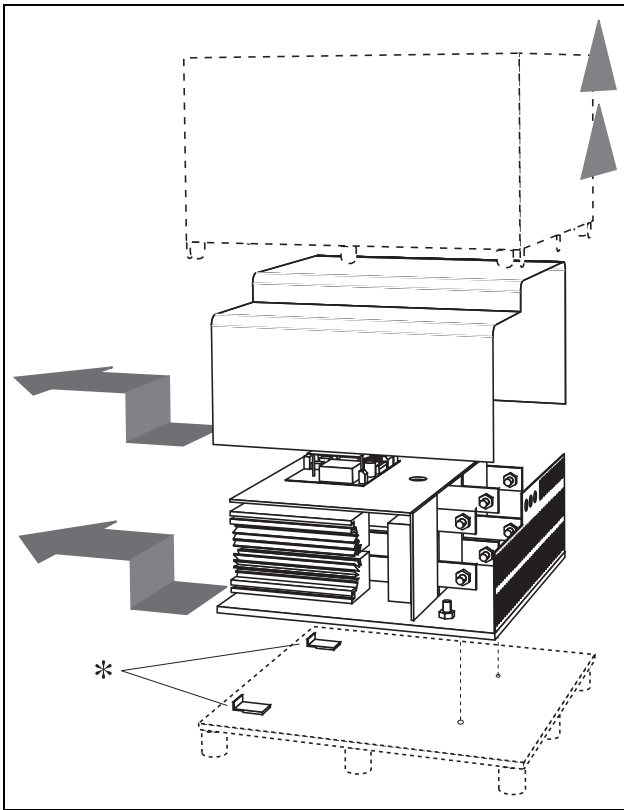

Fig. 2 Unpacking MSF-310 and larger models.

1.8 Glossary

1.8.1 Abbreviations

In this manual the following abbreviations are used:

Table 2 Abbreviations

Abbreviation	Description
FLC	Full load current
DOL	Direct on-line

1.8.2 Definitions

In this manual the following definitions for current, voltage, power, torque and speed are used:

Table 3 Definitions

Name	Description	Unit
I_n	Nominal motor current	A
I_{nsoft}	Nominal softstarter current	A
N_{nsoft}	Nominal softstarter speed	rpm
P_n	Nominal motor power	kw, HP
P_{normal}	Normal load	% of P_n
P_{nsoft}	Nominal softstarter power	kW, HP
T_n	Nominal motor torque	Nm, lbft
U	Mains supply voltage	V
U_n	Nominal motor voltage	V

2. Description

In this chapter different starting methods for induction motors are explained and compared. The functionality of softstarters with torque control and their advantages and limitations compared to other starting methods are explained.

First a brief account of the background theory of starting induction motors will be given in section 2.1. Thereafter the different starting methods based on the usage of reduced voltage will be described and compared. This chapter will also cover softstarters with torque control. In section 2.3 some common starting methods based on other physical principles are explained. With this information some limitations of the reduced voltage starters will become clear. In section 2.4 there is a brief analysis of which applications may benefit from using a softstarter.

2.1 Background theory

The following two sections deal with motors with squirrel-cage rotors. In contrast to a wound rotor, the squirrel-cage rotor consists of straight conductors, which are short-circuited together at both ends.

When such a motor is connected directly to the line voltage it will typically draw a starting current of about 5 to 8 times its nominal current while the resulting starting torque will be about 0.5 to 1.5 times its nominal torque. In the following picture a typical starting characteristic is shown. The x-axis represents the speed relative to the synchronous speed while the y-axis shows the torque and the current respectively, with those quantities normalized to their nominal values. The dashed line indicates the nominal values.

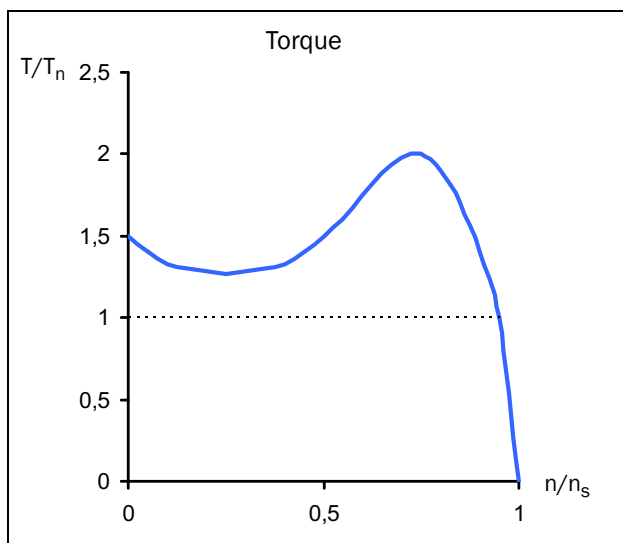

Fig. 3 Typical torque characteristics for the DOL start

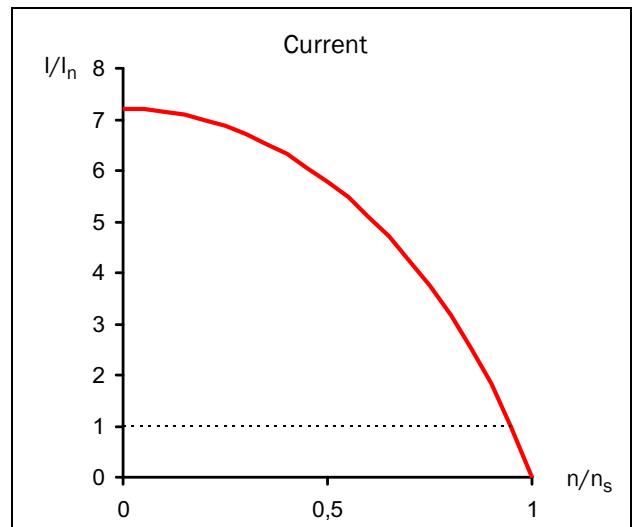

Fig. 4 Typical current characteristics for the DOL start

For many industrial applications direct on-line starting is not convenient, as the supply in this case has to be dimensioned to deliver the unnecessarily high starting current. Moreover, most applications do not gain anything from the high starting torque. Instead there is a risk of mechanical wear or even damage because of the resulting jerk at speedup.

The acceleration torque is determined by the difference between motor and load torque. The figure below shows some typical torque characteristics for constant speed applications. For comparative purposes, the induction motors' torque characteristic is added to the diagram.

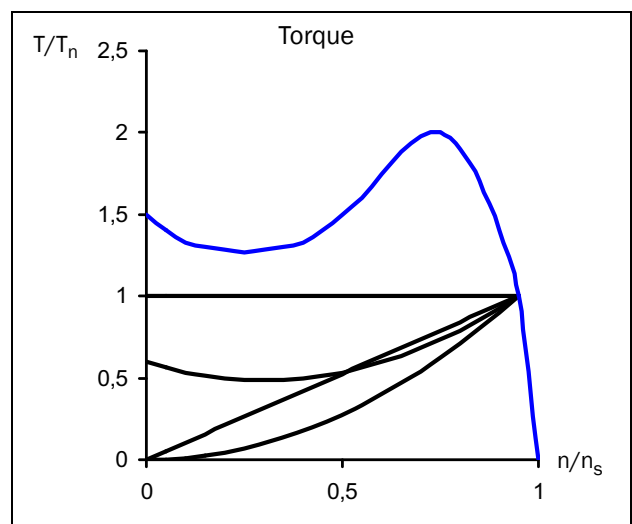

Fig. 5 Typical load torque characteristics

Typical applications with constant load are elevators, cranes and conveyors. Linear load characteristics are found for calendar rollers and smoothing machines; quadratic correlation between speed and torque is typical for pumps and fans. Some applications like conveyors or screws may need an initial torque boost. However, for many applications it can be seen that the torque needed is much lower than the torque delivered by the induction motor in a DOL start.

A common method to reduce both starting torque and current is to decrease the motor voltage during starting. The following figure shows how the motor's torque and current characteristics are changed when the supply voltage is reduced.

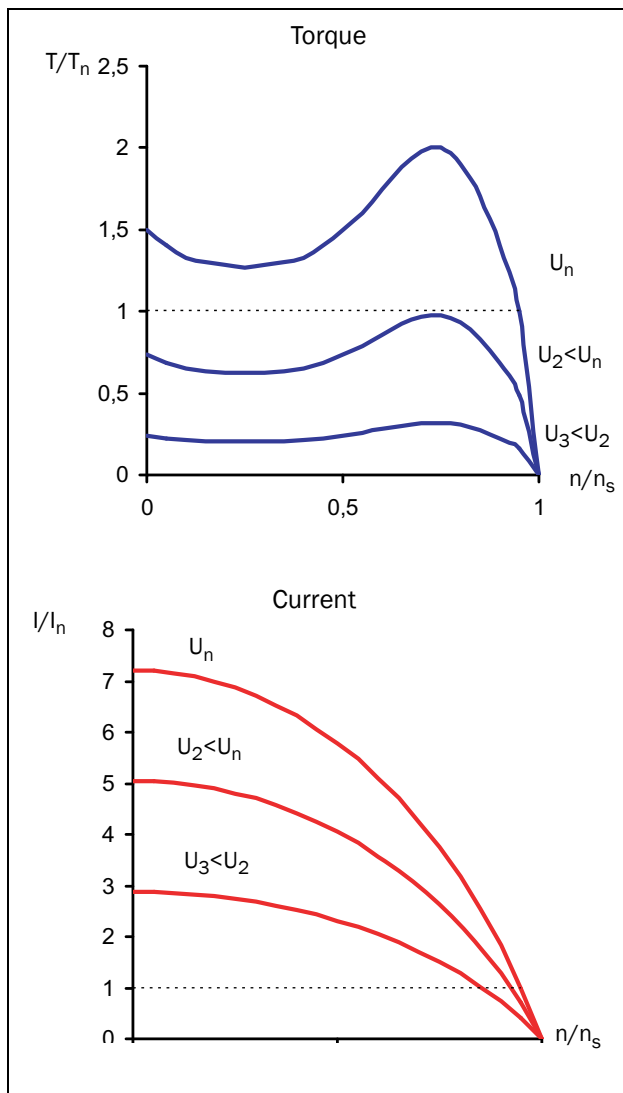

Fig. 6 Reduced voltage start

A general rule of thumb is that the torque at each operating point is roughly proportional to the square of the current. This means when the motor current is decreased by a factor of two by means of reducing the supply voltage, the torque delivered by the motor will be decreased by a factor of four (approximately).

$$\begin{aligned}
 &V_{\text{NK}} \approx 3 \cdot V_{\text{FQN}} \\
 &I_{\text{NK}} \approx 3 \cdot I_{\text{FQN}} \\
 &T_{\text{NK}} \approx 3 \cdot T_{\text{FQN}}
 \end{aligned}$$

This relationship is the base for any starting method using reduced voltage. It can be seen that the possibility of reducing the starting current depends on the correlation between the motor's and the load's torque characteristic. For the combination of an application with very low starting load and a motor with very high starting torque, the starting current may be reduced significantly by means of decreasing the voltage during start. However, for applications with high starting load it may – depending on the actual motor – not be possible to reduce the starting current at all.

2.2 Reduced voltage starting

This section describes different starting methods which are based on the reduced-voltage principle explained above. A pump and its quadratic torque characteristic are used as an example.

The star-delta starter is the simplest example of a reduced voltage starter. The motor phases are first star connected; at about 75% of nominal speed the phase connection is then changed to delta. To enable star-delta start, both ends of all three motor windings have to be available for connection. Moreover, the motor has to be dimensioned for the (higher) voltage in the delta connection. The following figure shows the resulting torque and current characteristics.

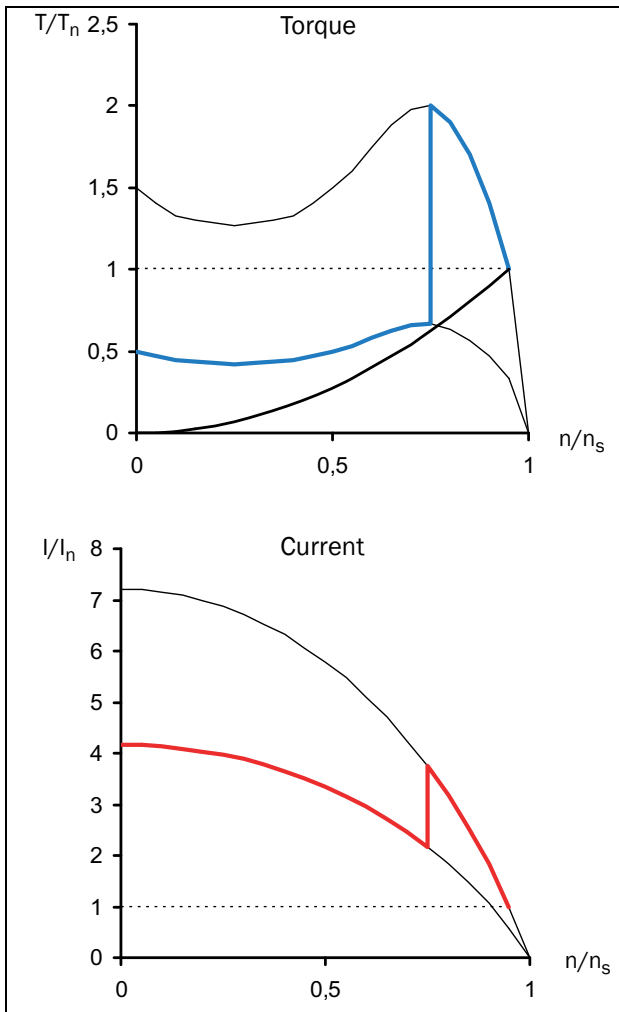

Fig. 7 Star-delta start

The disadvantage of the star-delta start is that it cannot be adapted to a special application. Both the voltage in star and in delta connection are defined by the supply, the resulting starting performance depends on the motor's DOL characteristic. For some applications the star-delta starter cannot be used as the resulting torque in star connection is too low to start rotating the load. On the other hand for low load applications further savings of starting current are impossible even though a big torque reserve is available. Moreover, the resulting abrupt rise of torque first at start and later when changing from star to delta connection may contribute to mechanical wear. The high transient currents during start-delta transition create unnecessary excess heat in the motor.

Better performance is achieved with a voltage ramp start, which a simple electronic softstarter can provide. The voltage is increased linearly from an initial value to the full supply voltage by means of phase angle control. The resulting torque and current characteristics are shown in the following figure.

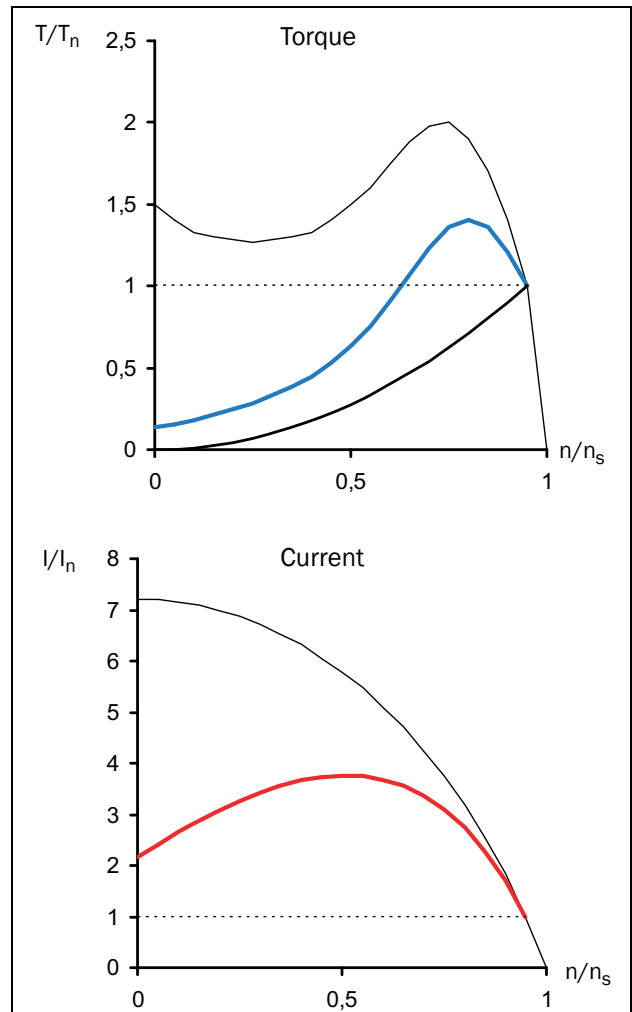

Fig. 8 Soft starting – voltage ramp

Obviously a much smoother start is realized compared to the star-delta start and the starting current is decreased.

A softstarter is often used to keep the starting current below a desired level. For the example above, setting a current limit of three times the nominal current may be desirable. The following figure shows the resulting torque and current characteristics.

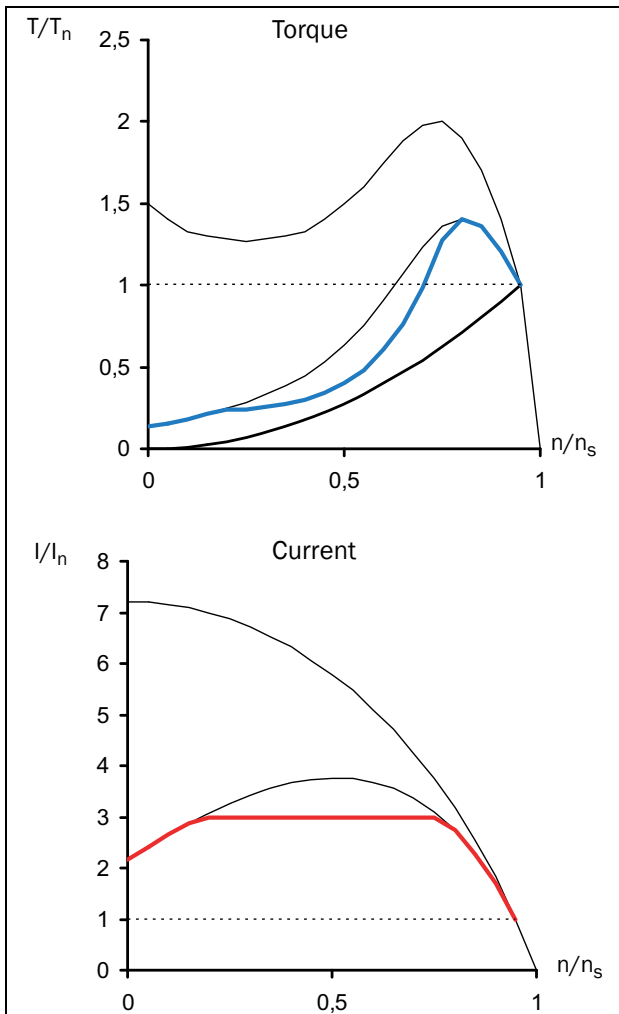

Fig. 9 Soft starting – voltage ramp with current limit

Once again the figure illustrates that the resulting performance depends on the combination of motor and load characteristics. In the example above the motor torque is close to the load torque at about half speed. This means for some other applications with different load characteristics (for example a linear torque-speed correlation) this particular motor would need more than three times the nominal current to start.

The most sophisticated electronic softstarters use torque control, which results in an almost constant acceleration during the start. A low starting current is also achieved. However, this start method also uses reduced motor voltage and the quadratic correlation between current and torque described in the first section of this chapter is still valid. This means, the lowest possible starting current is determined by the combination of motor and load characteristics.

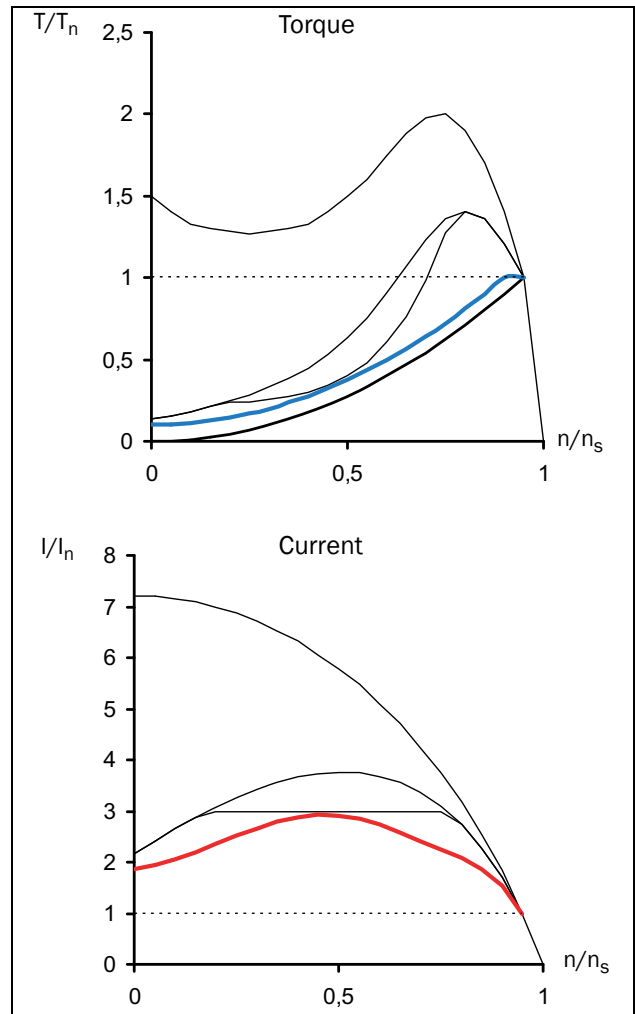

Fig. 10 Soft starting – torque control

For optimal starting performance, correct setting of the softstarter's parameters such as initial torque and end torque at start and start time is important. The choice of parameters is explained in detail in section 8.7, page 56.

2.3 Other starting methods

In contrast to the preceding sections of this chapter, which focused on squirrel-cage motors, slip-ring motors are dealt with later on. A slip-ring motor is equipped with a wound rotor; one end of each rotor winding is available for external connection via slip-rings. These motors are often optimized for rotor resistance starting, i.e. with short-circuited rotor windings they develop a very low torque at an extremely high current. For starting external resistances are connected to the rotor windings. During the start, the resistance value is decreased in several steps until the rotor windings are short-circuited at nominal speed. The following figure shows typical torque and current characteristics for a slip-ring motor during the start with an external rotor-resistance starter.

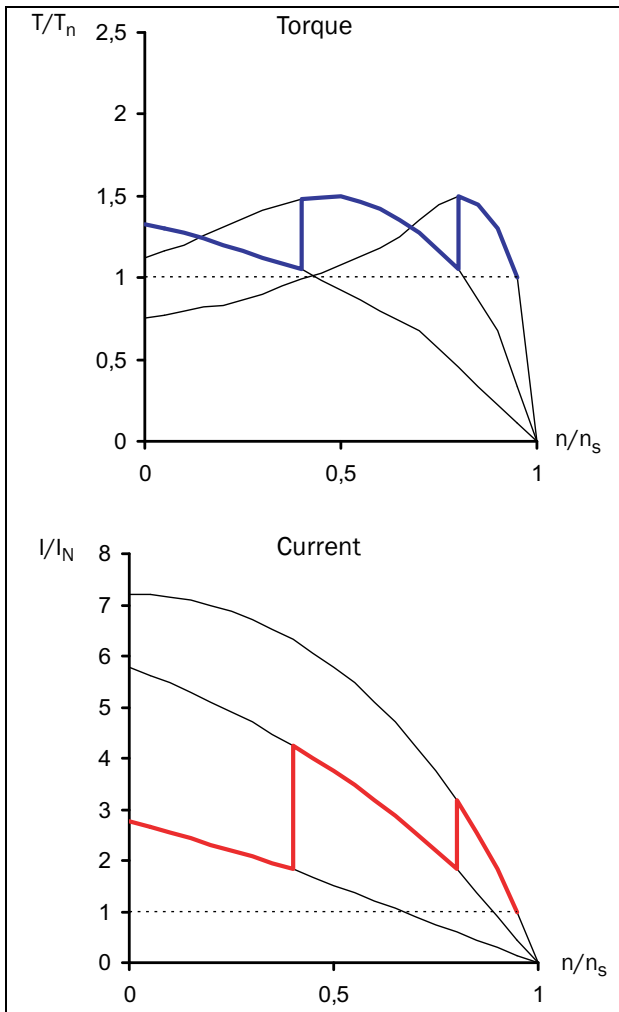

Fig. 11 Rotor-resistance starting

Because of the low starting torque it is often not possible to short-circuit the rotor windings and replace the rotor-resistance starter with a softstarter. However, it is always possible to use a frequency inverter instead. The following illustration shows how the torque and current characteristics are affected when the stator frequency is changed.

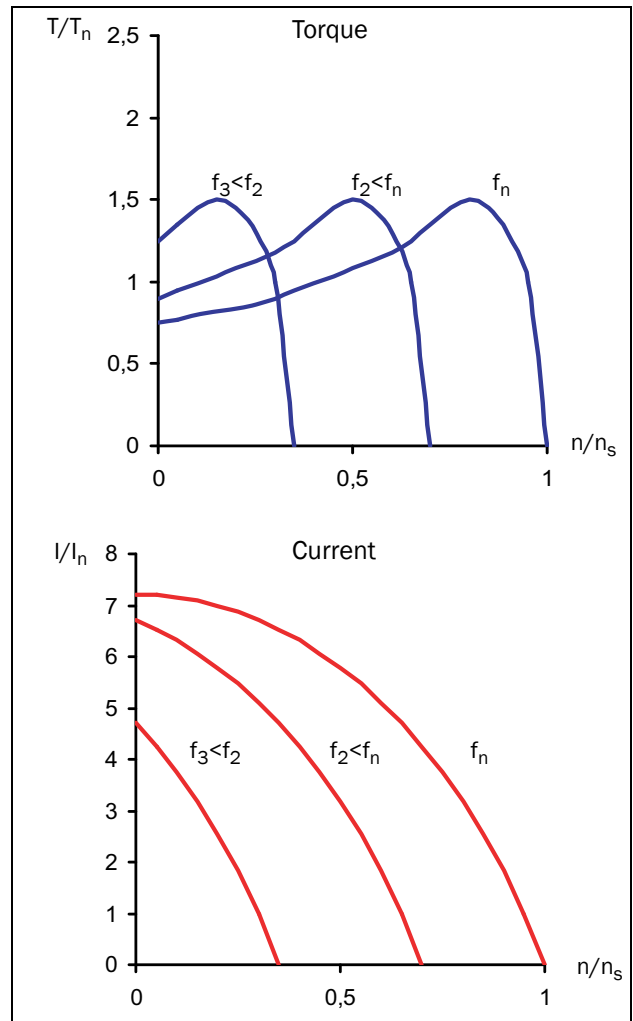

Fig. 12 Voltage/frequency regulation

Thus, such a motor can be started with a quite simple frequency inverter with voltage-frequency regulation. This solution is also valid for all other applications, which for some reason (high load torque compared to motor torque etc.) cannot be started by a softstarter.

2.4 Use of softstarters with torque control

To determine if a specific application benefits from using a softstarter at all, the correlation between the motor's torque characteristic during the start and the load's requirements has to be evaluated. As it can be seen from the examples above, the application will only benefit from using a softstarter if the load torque during the start is clearly below the motor's starting capacity. However, loads with a high initial release torque may also profit from a softstarter. In this case an initial torque boost can be used, thereafter the start ramp is continued reducing the starting current considerably.

The profit can be maximized when using a softstarter with torque control. To be able to configure the torque control parameters for optimal performance, the load characteristics (linear, square or constant load, need of initial release torque) must be known. In this case a proper torque control method (linear or square) can be chosen and torque boost can be enabled if needed. A description of the load characteristics of several common applications and guidelines for proper settings are found in chapter 6, page 31, Applications and Functions Selection. Optimization of the torque control parameter is explained in detail in section 8.7, page 56.

3. Mounting

This chapter describes how to mount the MSF 2.0 softstarter. Before mounting it is recommended that the installation be planned out first:

- Be sure that the softstarter suits the mounting location.
- The mounting site must support the weight of the softstarter.
- Will the softstarter continuously withstand vibrations and/or shocks?
- Consider using a vibration damper.
- Check ambient conditions, ratings, required cooling air flow, compatibility of the motor, etc.
- Do you know how the softstarter will be lifted and transported?

Make sure that the installation is performed in accordance with the local safety regulations of the electricity supply company. And in accordance with DIN VDE 0100 for setting up heavy current plants.

Care must be taken to ensure that personnel do not come into contact with live circuit components.



WARNING!
Never operate the softstarter with the front cover removed.

3.1 Installation of the softstarter in a cabinet

When installing the softstarter:

- Ensure that the cabinet will be sufficiently ventilated after the installation.
- Keep the minimum free space, listed in the Table 4.
- Ensure that air can flow freely from the bottom to the top.

NOTE: When installing the softstarter, make sure it does not come into contact with live components. The heat generated must be dispersed via the cooling fins to prevent damage to the thyristors (free circulation of air).

MSF-017 to MSF-835 are all delivered as enclosed versions with front opening. The units have bottom entry for cables etc. see Fig. 20 on page 21 and Fig. 22 on page 23. MSF-1000 and MSF-1400 are delivered as open chassis.

3.1.1 Cooling

Table 4 Minimum free space

MSF model	Minimum free space (mm):		
	above 1)	below	at side
-017, -030, -045	100	100	0
-060, -075, -085	100	100	0
-110, -145	100	100	0
-170, -210, -250	100	100	0
-310, -370, -450	100	100	0
-570, -710, -835	100	100	0
-1000, -1400	100	100	100

1) Above: wall-softstarter or softstarter-softstarter

3.1.2 Mechanical specifications including mechanical drawings

Table 5

MSF Model	Dimensions H*W*D [mm]	Mounting position [Vertical/Horizontal]	Weight [kg]	Connection busbars [mm]	PE screw	Cooling system	Protection class
-017, -030	320*126*260	Vertical	6.7	15*4, Cu (M6)	M6	Convection	IP20
-045	320*126*260	Vert. or Horiz.	6.9	15*4, Cu (M6)	M6	Fan	IP20
-060, -075, -085	320*126*260	Vert. or Horiz.	6.9	15*4, Cu (M8)	M6	Fan	IP20
-110, -145	400*176*260	Vert. or Horiz.	12	20*4, Cu (M10)	M8	Fan	IP20
-170, -210, -250	500*260*260	Vert. or Horiz.	20	30*4, Cu (M10)	M8	Fan	IP20
-310, -370, -450	532*547*278	Vert. or Horiz.	46	40*8, Al (M12)	M8	Fan	IP20
-570, -710, -835	687*640*302	Vert. or Horiz.	80	40*10, Al (M12)	M8	Fan	IP20
-1000, -1400	900*875*336	Vert. or Horiz.	175	80*10, Al (M12)		Fan	IP00

Table 6 Tightening torque for bolts [Nm].

MSF models	Tightening torque for bolts [Nm]		
	Cable	PE cable	PCB-terminals
-017, -030, -045	8	8	0.5
-060, -075, -085	12	8	0.5
-110, -145	20	12	0.5
-170, -210, -250	20	12	0.5
-310, -370, -450	50	12	0.5
-570, -710, -835	50	12	0.5
-1000, -1400	50	12	0.5

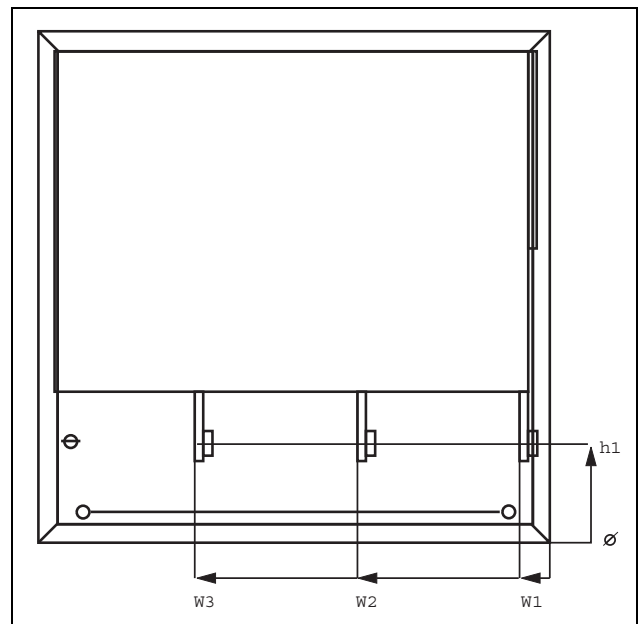

Fig. 13 Busbar distances MSF-310 to MSF-835.

Table 7 Busbar distances

MSF model	Dist. h1 (mm)	Dist. W1 (mm)	Dist. W2 (mm)	Dist. W3 (mm)
-310 to -450	104	33	206	379
-570 to -835	129	35	239.5	444
-1000 -1400		55	322.5	590.5

Mounting schemes

MSF-017 to MSF-250

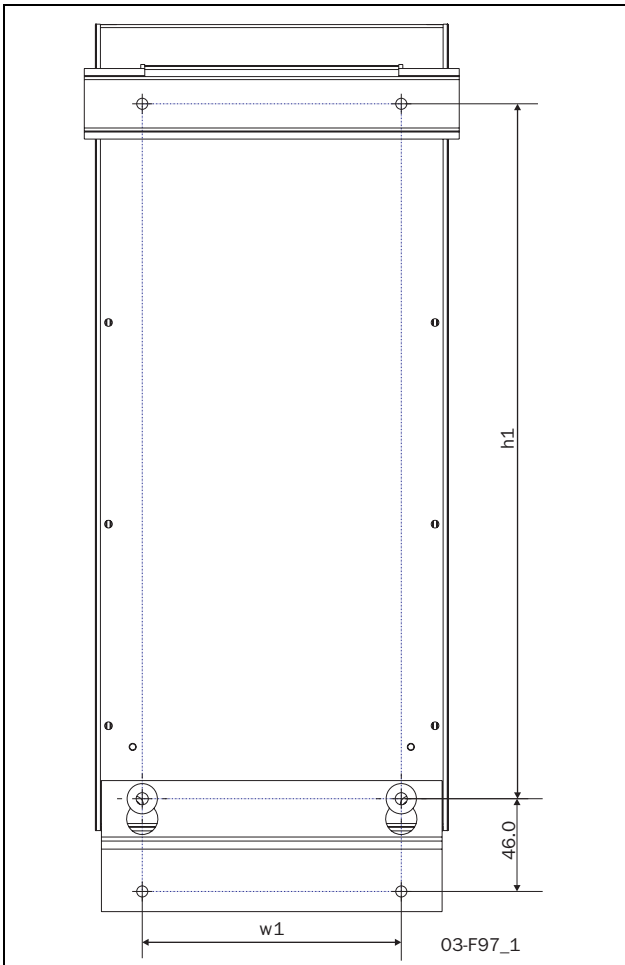

Fig. 14 Hole pattern for MSF-017 to MSF-250 (backside view).

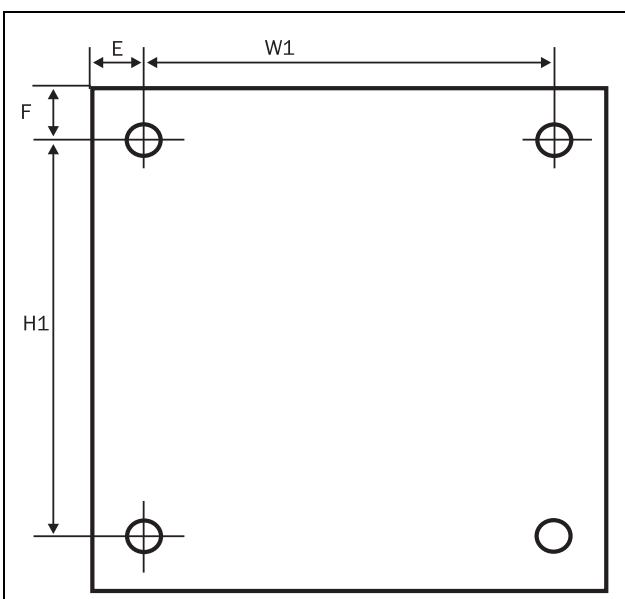

Fig. 15 Hole pattern for screw attachment, MSF-310 to MSF-835. Hole distance (mm).

Table 8

MSF Model	Hole dist. w1 [mm]	Hole dist. H1 [mm]	Hole dist. E	Hole dist. F	Diam./screw
-017, -030, -045	78.5	265			5.5/M5
-060, -075, -085	78.5	265			5.5/M5
-110, -145	128.5	345			5.5/M5
-170, -210, -250	208.5	445			5.5/M5
-310, -370, -450	460	450	44	39	8.5/M8
-570, -710, -835	550	600	45.5	39	8.5/M8
-1000, -1400					8.5/M8

Observe that the two mounting hooks supplied (see section 1.7, page 6 and Fig. 2 on page 7) must be used for mounting the softstarter as upper support (only MSF-310 to MSF-835).

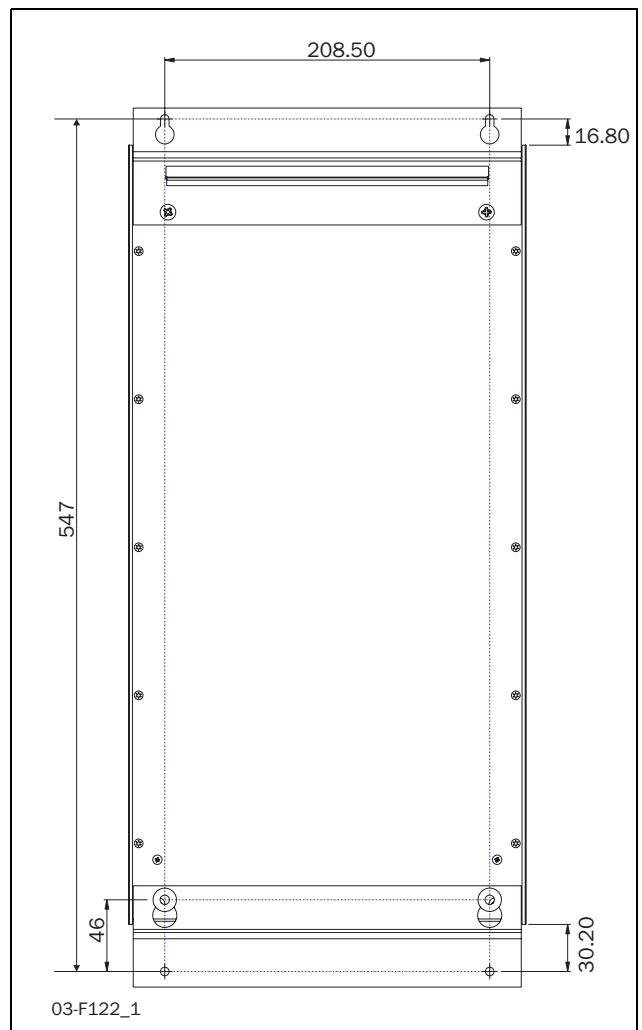

Fig. 16 Hole pattern for MSF-170 to MSF-250 with upper mounting bracket instead of DIN rail.

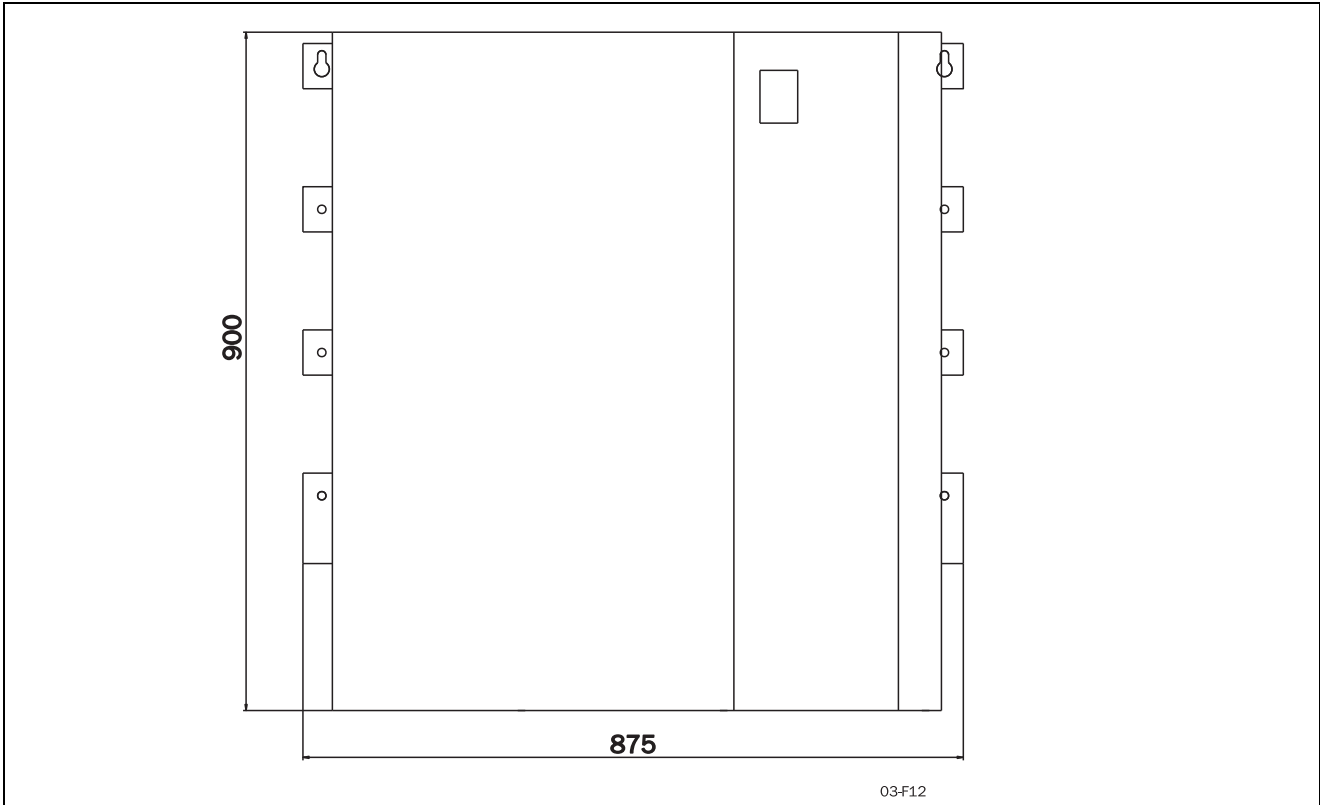

Fig. 17 MSF-1000 to MSF-1400

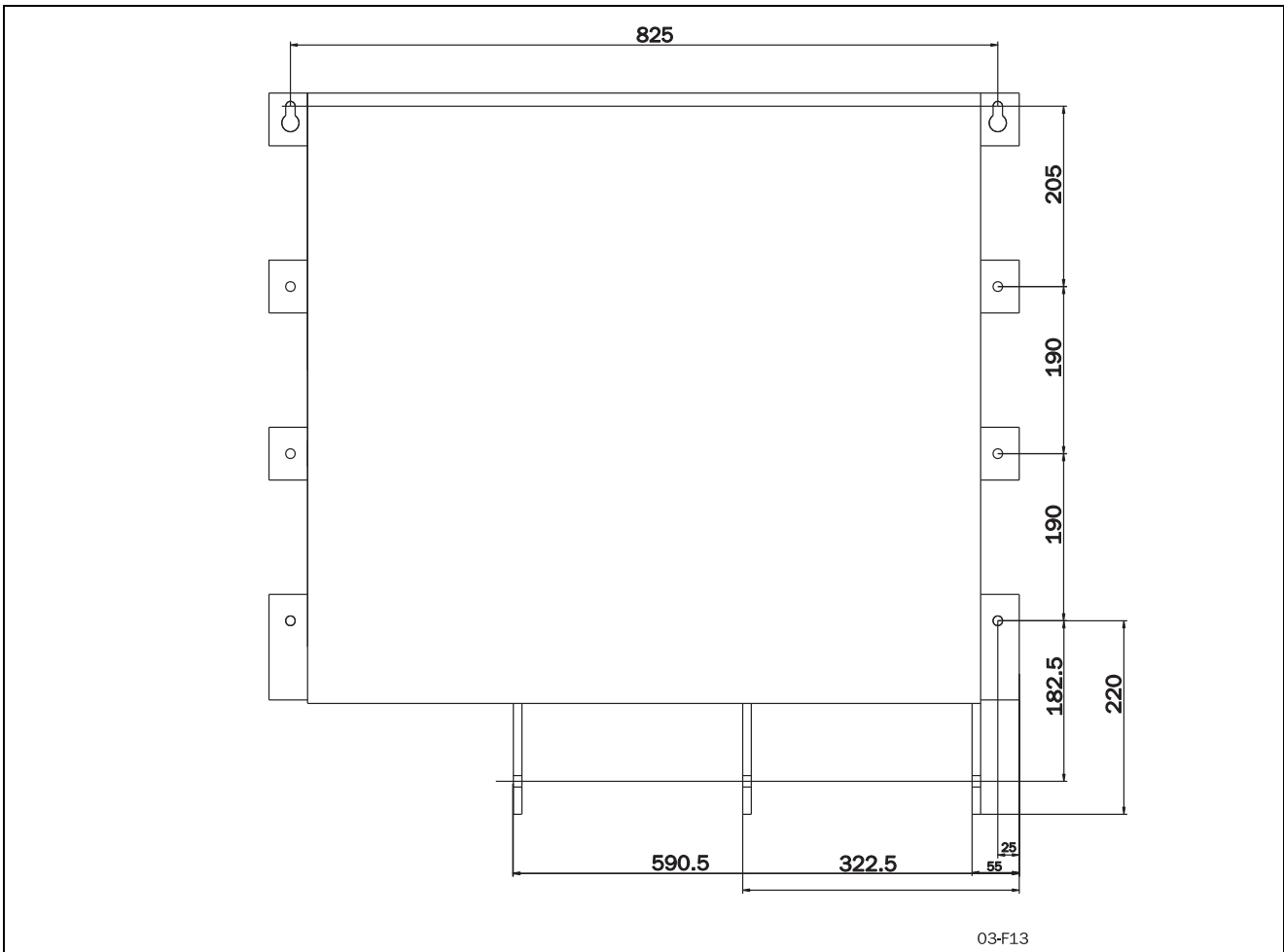

Fig. 18 Hole pattern busbar MSF-1000 to MSF-1400.

4. Connections

The description of installation in this chapter follows the EMC standards and the Machinery Directive.

If the softstarter is temporarily stored before being connected, please check the technical data for environmental conditions. If the softstarter is moved from a cold storage room to the room where it is to be installed, condensation can form on it. Allow the softstarter to become fully acclimatised and wait until any visible condensation has evaporated before connecting the mains voltage.

NOTE: The softstarter must be wired with shielded control cable to fulfil EMC regulations according to section 13.7, page 122.

NOTE: With the IT-net option the connection of the mains supply EMC-filters to earth are removed. In this case outer measures have to be taken to fulfil EMC regulations according to section 13.7, page 122.

NOTE: For UL-approval use 75° C Copper wire only.

4.1 Connecting mains and motor cables

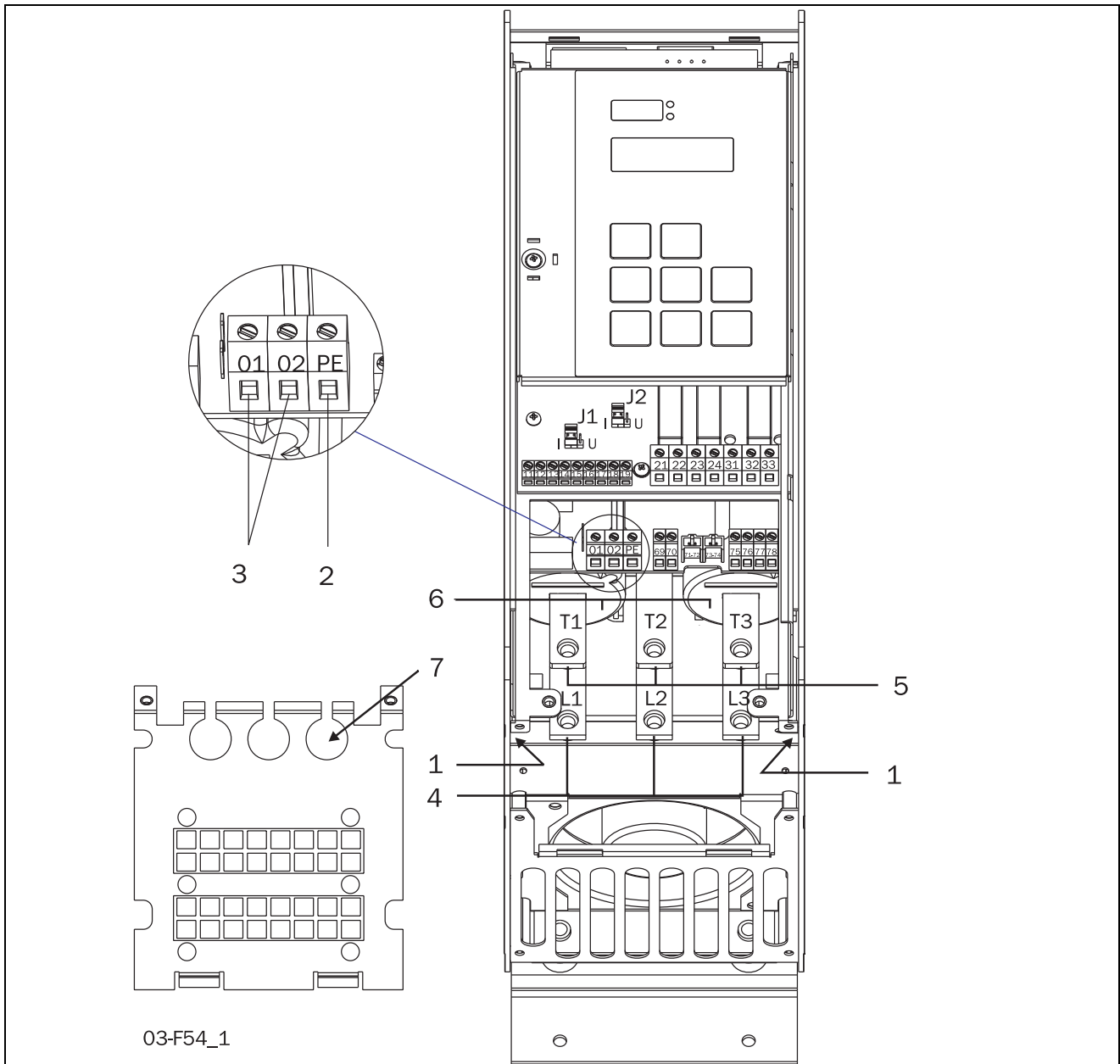

Fig. 19 Connection of MSF-017 to MSF-085.

Connection of MSF-017 to MSF-085

7. Mounting of EMC gland for control cables

Device connections

1. Protective earth, \perp (PE), mains supply, motor (on the right and left inside of the cabinet)
2. Protective earth, \perp (PE), control supply voltage
3. Control supply voltage connection 01, 02
4. Mains supply L1, L2, L3
5. Motor power supply T1, T2, T3
6. Current transformers (can be mounted outside for bypass see section 8.7.5, page 68)

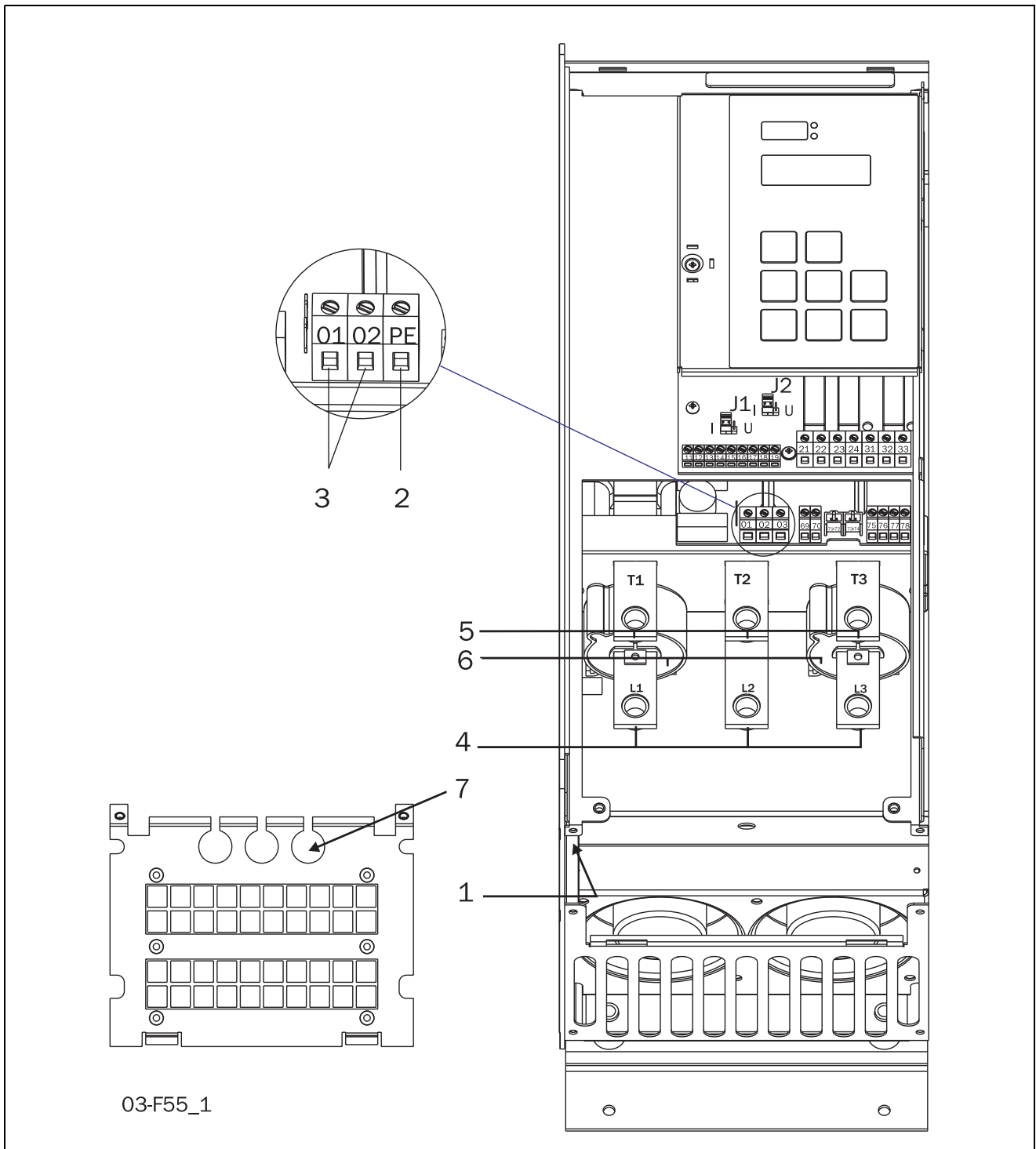

Fig. 20 Connection of MSF-110 to MSF-145.

Connection of MSF-110 to MSF-145

Device connections

1. Protective earth, \perp (PE), mains supply, motor (on the left inside of the cabinet)
2. Protective earth \perp (PE), control supply voltage
3. Control supply voltage connection 01, 02
4. Mains supply L1, L2, L3

5. Motor power supply T1, T2, T3
6. Current transformers (can be mounted outside for bypass see section 8.7.5, page 68)
7. Mounting of EMC gland for control cables

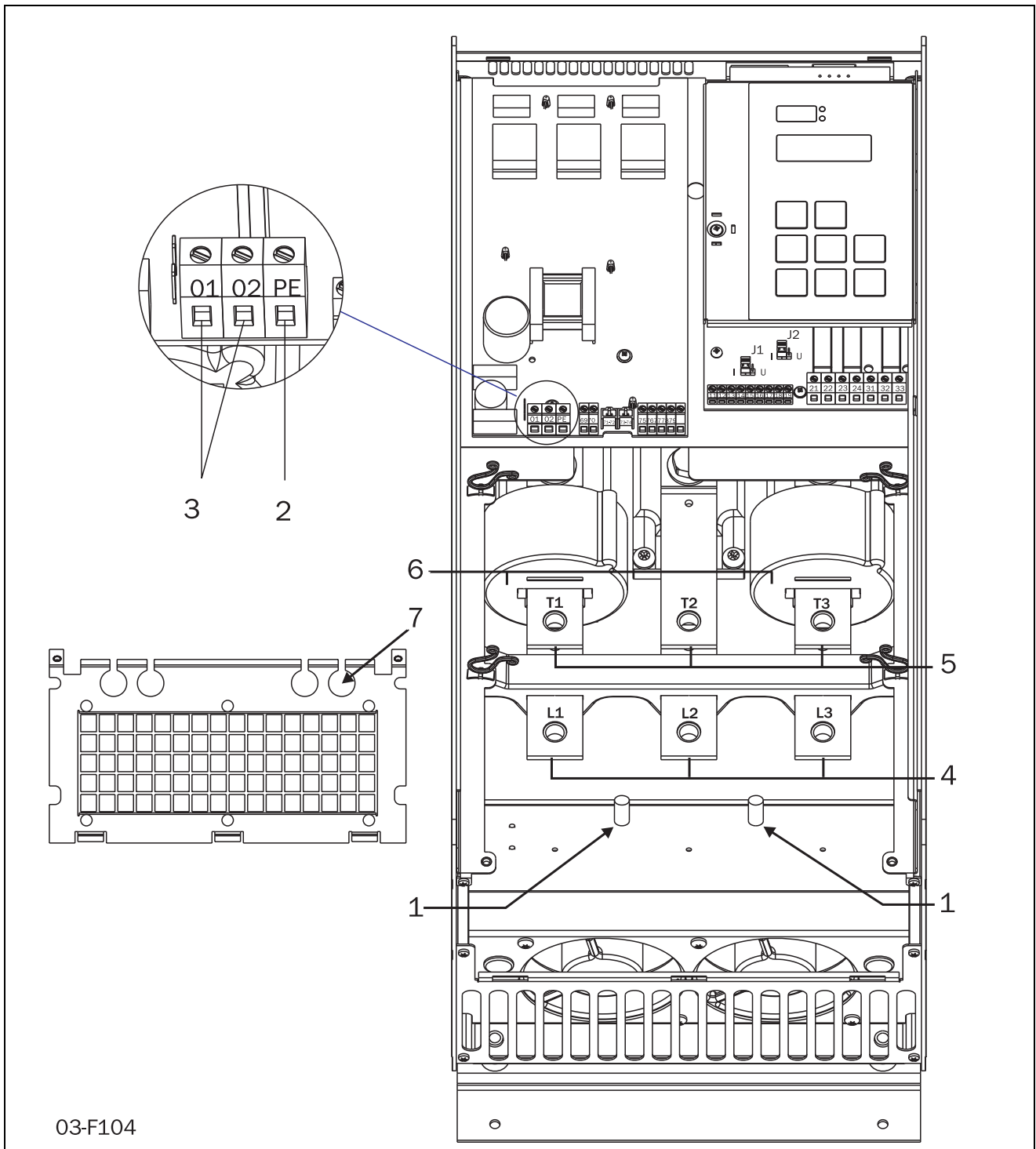

03-F104

Fig. 21 Connection of MSF-170 to MSF-250.

Connection of MSF-170 to MSF-250

Device connections

1. Protective earth, \perp (PE), mains supply, motor (on the left inside of the cabinet)
2. Protective earth \perp (PE), control supply voltage
3. Control supply voltage connection 01, 02
4. Mains supply L1, L2, L3

5. Motor power supply T1, T2, T3
6. Current transformers (can be mounted outside for bypass see section 8.7.5, page 68)
7. Mounting of EMC gland for control cables

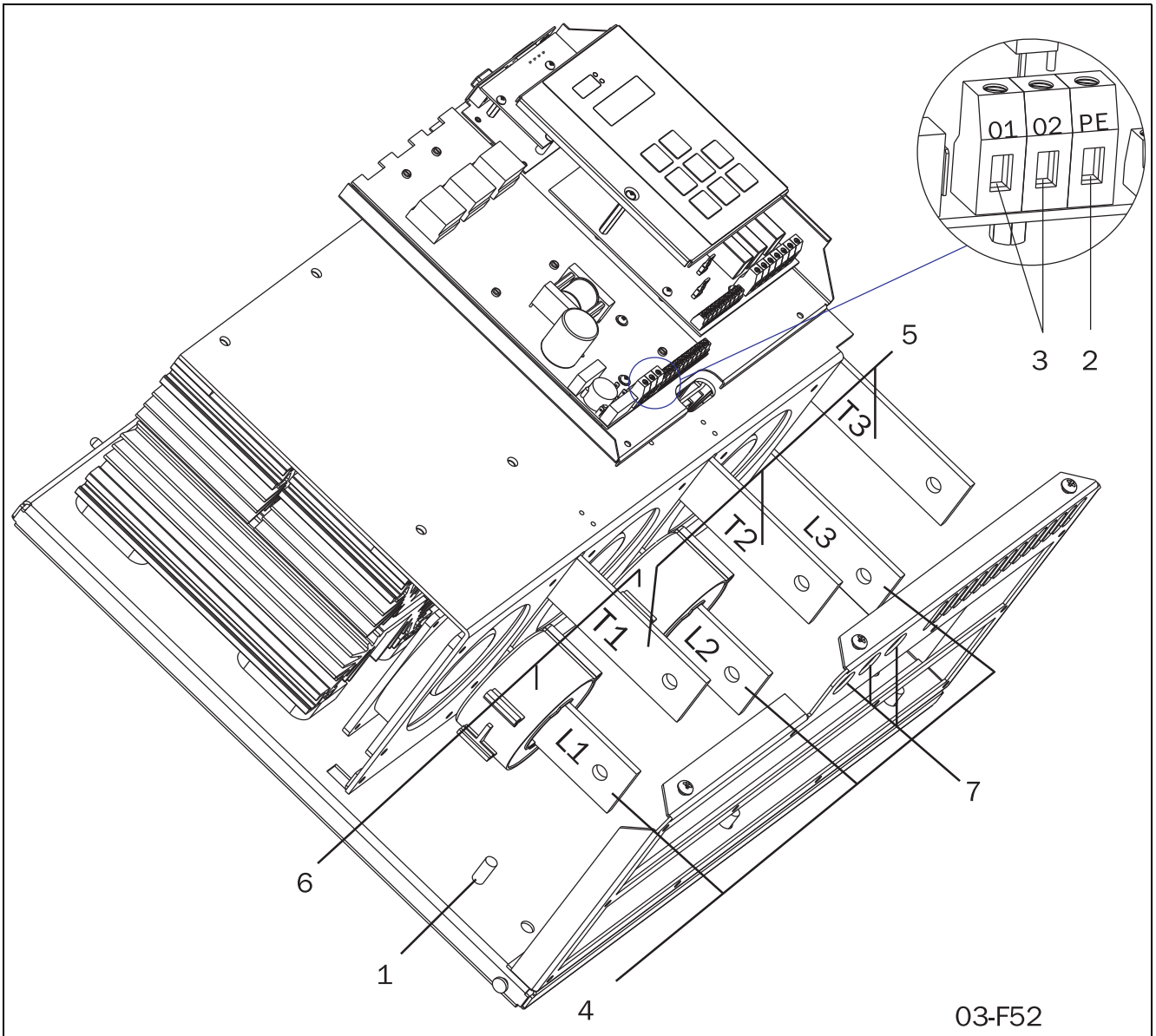

Fig. 22 Connection of MSF-310 to MSF-1400.

Connection of MSF-310 to MSF-1400

Device connections

1. Protective earth, \perp (PE), mains supply and motor
2. Protective earth, \perp (PE), control supply voltage
3. Control supply voltage connection 01, 02
4. Mains supply L1, L2, L3
5. Motor power supply T1, T2, T3
6. Current transformers (possible to mount outside for bypass see section 8.7.5, page 68)
7. Mounting of EMC gland for control cables

4.2 Control Connection

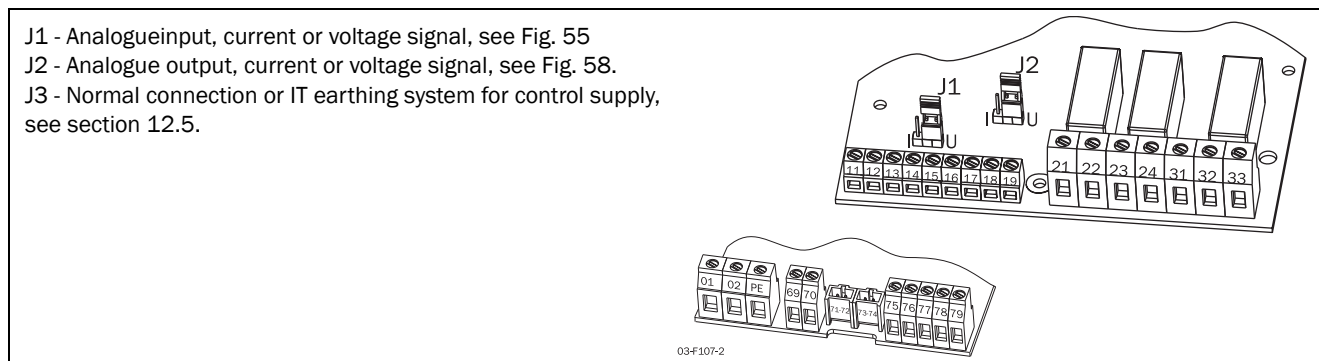

Fig. 23 PCB (control board) connections.

Table 9 PCB Terminals

Terminal	Function	Electrical characteristics
01	Control supply voltage	100-240 VAC $\pm 10\%$ alternative
02		380-500 VAC $\pm 10\%$ see rating plate
PE	Protective Earth	Protective Earth
11	Digital input 1	0-3 V \rightarrow 0; 8-27 V \rightarrow 1.
12	Digital input 2	Max. 37 V for 10 sec. Impedance to 0 VDC: 2.2 k Ω .
13	Control signal supply voltage to PCB terminal 11 and 12, 10 k Ω potentiometer, etc.	+12 VDC $\pm 5\%$. Max. current from +12 VDC: 50 mA. Short circuit-proof but not overload-proof.
14	Analogue input, 0-10 V, 2-10 V, 0-20 mA and 4-20 mA/digital input.	Impedance to terminal 15 (0 VDC) voltage signal: 125 k Ω , current signal: 100 Ω .
15	GND (common)	0 VDC
16	Digital input 3	0-3 V \rightarrow 0; 8-27 V \rightarrow 1.
17	Digital input 4	Max. 37 V for 10 sec. Impedance to 0 VDC: 2.2 k Ω .
18	Control signal supply voltage to PCB terminal 16 and 17, 10 k Ω potentiometer, etc.	+12 VDC $\pm 5\%$. Max. current from +12 VDC = 50 mA. Short circuit-proof but not overload-proof.
19	Analogue output	Analogue output contact: 0-10 V, 2-10 V; min load impedance 700 Ω 0-20 mA and 4-20 mA; max load impedance 750 Ω
21	Programmable relay K1. Factory setting is "Operation" with indication by closing terminal 21 to 22.	1-pole closing contact, 250 VAC 8 A or 24 VDC 8 A resistive, 250 VAC, 3 A inductive.
22		
23	Programmable relay K2. Factory setting is "Full voltage" with indication by closing terminals 23 to 24.	1-pole closing contact, 250 VAC 8 A or 24 VDC 8 A resistive, 250 VAC, 3 A inductive.
24		
31	Programmable relay K3. Factory setting is "All alarms". Indication by closing terminals 31 to 33 and opening terminals 32 to 33.	1-pole change-over contact, 250 VAC 8A or 24 VDC 8A resistive, 250 VAC, 3A inductive.
32		
33		
69-70	PTC Thermistor input	Alarm level 2.4 k Ω . Switch back level 2.2 k Ω .
71-72*	Clickson thermistor	Controlling softstarter cooling fan temperature MSF-310 - MSF-1400
73-74*	NTC thermistor	Temperature measuring of softstarter cooling fin
75	Current transformer input, cable S1 (blue)	Connection of L1 or T1 phase current transformer
76	Current transformer input, cable S1 (blue)	Connection of L3, T3 phase (MSF 017 to MSF 250) or L2, T2 phase (MSF 310 to MSF 1400)
77	Current transformer input, cable S2 (brown)	Common connection for terminals 75 and 76
78*	Fan connection	24 VDC
79*	Fan connection	0 VDC

*Internal connection, no customer use.

4.3 Minimum wiring

The figure below shows the “minimum wiring”. See section 3.1.2, page 16, for tightening torque for bolts etc.

1. Connect Protective Earth (PE) to earth screw marked \perp (PE).
2. Connect the softstarter between the 3-phase mains supply and the motor. On the softstarter the mains side is marked L1, L2 and L3 and the motor side T1, T2 and T3.
3. Connect the control supply voltage (100-240 VAC) for the control card at terminals 01 and 02.
4. Connect PCB terminals 12 and 13 (PCB terminals 11 and 12 must be linked) e.g. to a 2-position switch (on/off) or a PLC, etc., to obtain control of soft start/stop (for factory configuration of the digital inputs).
5. Ensure the installation complies with the appropriate local regulations.

NOTE: The softstarter should be wired with a shielded control cable to fulfil the EMC regulations outlined in section 1.6, page 6.

NOTE: If local regulations say that a mains contactor should be used, relay K1 can control it. Always use standard commercial, slow blow fuses, e.g. gI or gG types, to protect the wiring and prevent short circuiting. To protect the thyristors against short-circuit currents, superfast semiconductor fuses can be used if preferred. The normal guarantee is valid even if superfast semiconductor fuses are not used. All signal inputs and outputs are galvanically insulated from the mains supply.

4.4 Wiring examples

Fig. 55 on page 80 gives an wiring example with the following functions:

- Analogue start/stop, see description on page 80.
- External control of parameter set, see section 8.9.6, page 92
- Analogue output, see “Analogue output” on page 83
- PTC input, see description of Thermal motor protection in section 8.3.1, page 46.

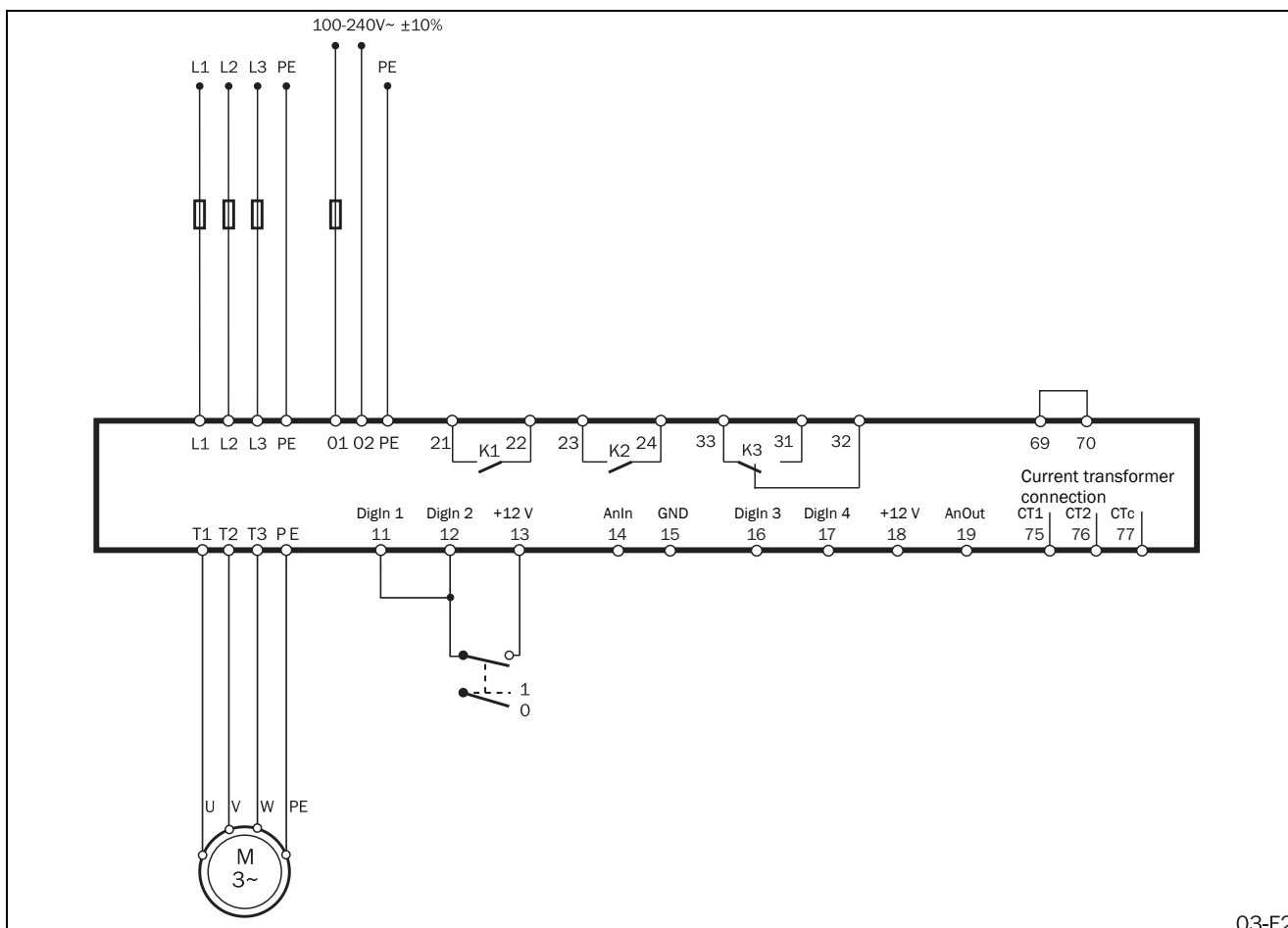

Fig. 24 Wiring circuit, “minimum wiring”.

5. How to get started

This chapter briefly describes the set-up for basic soft start and soft stop using the default “Torque control” function.



WARNING!
Mounting, wiring and setting the device into operation must be carried out by properly trained personnel.

5.1 Checklist

- Mount the softstarter as set out in chapter 3. page 15.
- Consider the power loss at rated current when dimensioning a cabinet, max. ambient temperature is 40°C.
- Check that the motor and supply voltage corresponds to the values on the softstarter’s rating plate.
- Connect the protective earth.
- Connect the motor circuit according to Fig. 25.
- Connect the control supply to terminals 01 and 02. The control supply voltage range is 100-240 VAC or 380-500 VAC, see rating plate.

- Connect relay K1 (terminals 21 and 22 on the softstarter) to the contactor – the softstarter then controls the contactor (for factory configuration of K1).
- Connect terminals 12 and 13 to, e.g., a 2-way switch (closing non-return) or a PLC and a jumper between 11 and 12, etc., to obtain control of soft start/soft stop. (For factory configuration of digital inputs 1 and 2.)
- Ensure the installation complies with the appropriate local regulations.

5.2 Applications



WARNING!
Make sure that all safety measures have been taken before switching on the power supply.

Switch on the control supply voltage (normally 1 x 230 V); all segments in the display and the two LEDs will be illuminated for a few seconds. Then the display will show menu [100]. An illuminated display indicates there is control supply voltage to the softstarter unit. Check that you have mains supply voltage to the mains contactor or to the thyristors. The settings are carried out according as follows:

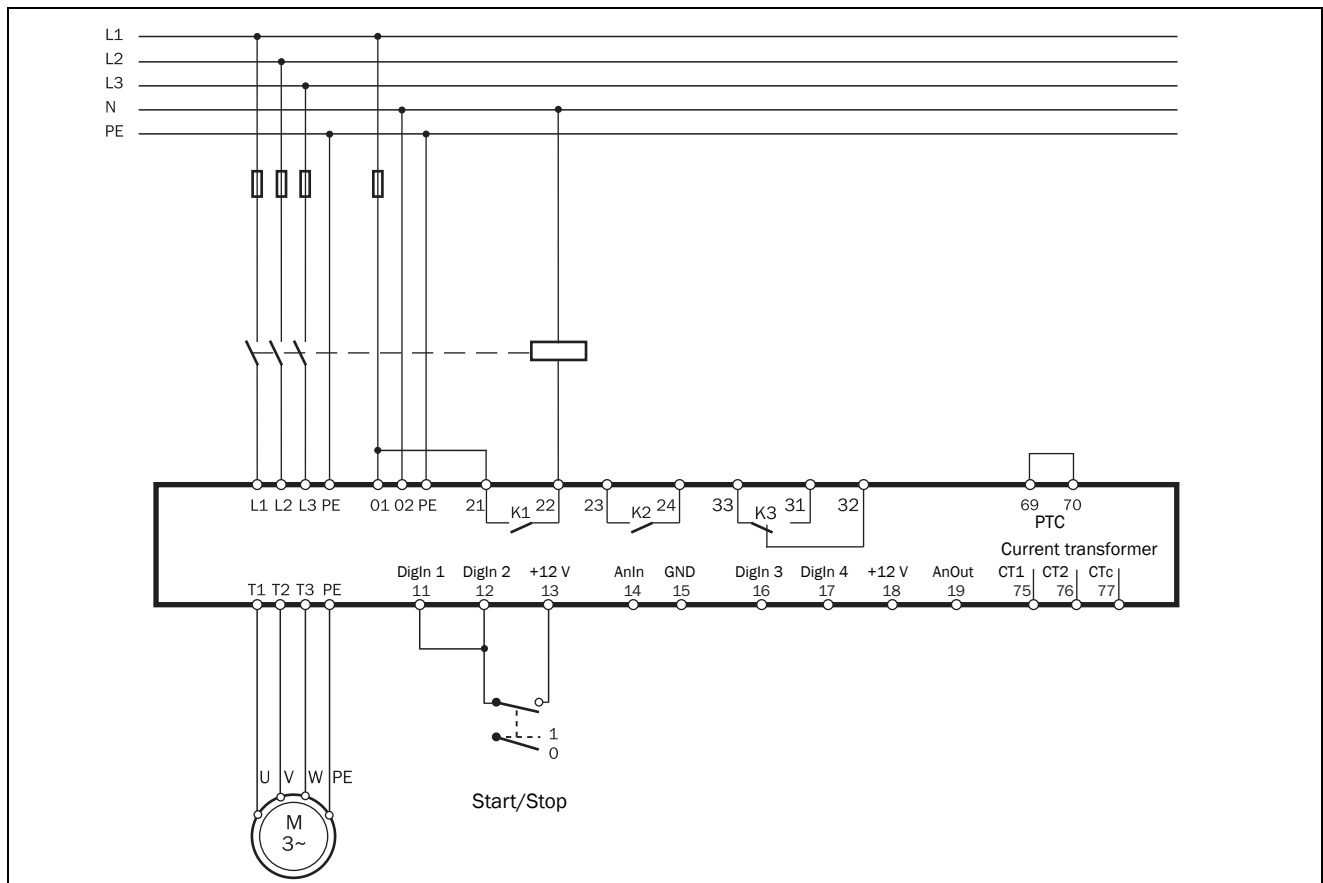

Fig. 25 Standard wiring.

5.3 Motor data

Set the data, according to the motor type plate, to obtain optimal settings for start, stop and motor protection.

NOTE: The default settings are for a standard 4-pole motor according to the nominal power of the softstarter. The softstarter will run even if no specific motor data is selected, but the performance will not be optimal.

210 ^o		Setting
Nominal motor voltage		
4 0 0		
Default:	400 V	
Range:	200-700 V	
200-700	Nominal motor voltage.	

211 ^o		Setting
Nominal motor current		
1 7		
Default:	I_{nsoft} in A	
Range:	25-200% of I_{nsoft} in A	
25-200	Nominal motor current.	

212 ^o		Setting
Nominal motor power		
7.5		
Default:	P_{nsoft} in kW	
Range:	25-400% of P_{nsoft} in kW or HP.	
25-400	Nominal motor power.	

213 ^o		Setting
Nominal motor speed		
1 4 5 0		
Default:	N_{nsoft} in rpm	
Range:	500-3600 rpm	
500-3600	Nominal motor speed.	

214 ^o		Setting
Nominal power factor		
0.86		
Default:	0.86	
Range:	0.50-1.00	
0.50-1.00	Nominal motor power factor.	

215 ^o		Setting
Nominal frequency		
5 0		
Default:	50 Hz	
Range:	50 Hz, 60 Hz	
50, 60	Nominal frequency.	

5.4 Start and stop

315 ^o		Setting
Start time		
1 0		
Default:	10 s	
Range:	1-60 s	
1-60	Start time.	

320 ^o		Setting
Stop method		
4		
Default:	4 (Coast)	
Range:	1, 2, 3, 4, 5	
1	Linear torque control	
2	Square torque control	
3	Voltage control	
4	Coast	
5	Brake	

Default "Stop method" is Coast (freewheeling).

5.5 Setting the start command

As default the softstarter is set up for remote operation via terminals 11, 12 and 13. For easy commissioning it is possible to give start and stop signals via the control panel.

200		Setting
Control source		
2		
Default:	2 (Remote control)	
Range:	1, 2, 3	
1	Control panel.	
2	Remote control.	
3	Serial communication control.	

Parameter [200] must be set to 1 to be able to operate from control panel.

NOTE: Factory default setting is remote control (2).

To start and stop from the control panel, the “START/STOP” key is used.

To reset from the control panel, the “ENTER ↵ /RESET” key is used. A reset can be done both when the motor is running and when the motor is stopped. A reset by the control panel will not start or stop the motor.

5.6 Viewing the motor current

Set the display to menu [100]. Now the motor current can be viewed on the display.

100		Read-out
Current		
0.0		
Range:	0.0-9999 A	

5.7 Starting

Start the motor by pressing the “START/STOP” key on the control panel or through the remote control, PCB terminals 11, 12 and 13. When the start command is given, the mains contactor will be activated by relay K1 (softstarter terminals 21 and 22), and the motor then starts softly.

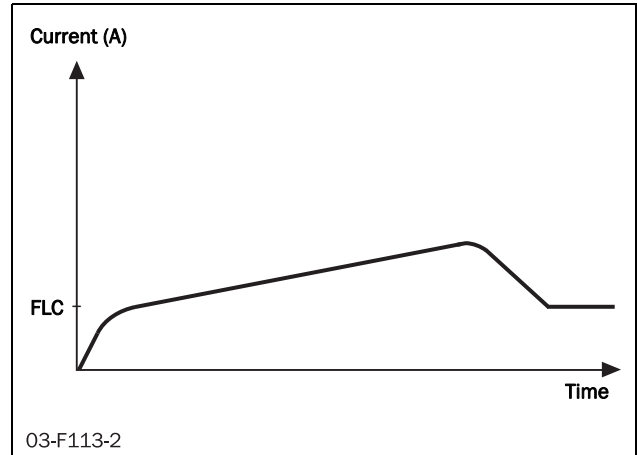

Fig. 26 Example of start current when the default torque control is used.

6. Applications and functions selection

This chapter is a guide to selecting the correct softstarter rating and softstarter functionality for different applications.

To make the right choice the following tools are used:

The norms AC53a and AC53b

These norms help select the softstarter rating with regard to duty cycle, starts per hour and maximum starting current.

The Applications Rating List

With this list the softstarter rating can be selected depending on the kind of application used. The list uses two levels, see Table 10, page 33.

The Applications Function List

This table gives an overview of the most common applications and their challenges. For each application MSF 2.0 solutions are proposed and a reference to the MSF 2.0 menus, which can be used, is given. See Table 11, page 34.

6.1 Softstarter rating according to AC53a

The IEC 60947-4-2 standard for electronic softstarters defines AC53a as a norm for dimensioning of softstarters for continuous running without bypass.

The MSF 2.0 softstarter is designed to run continuously.

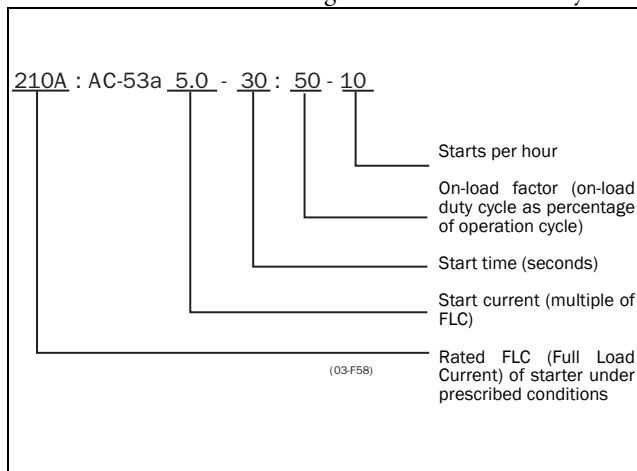

Fig. 27 AC53a rating example.

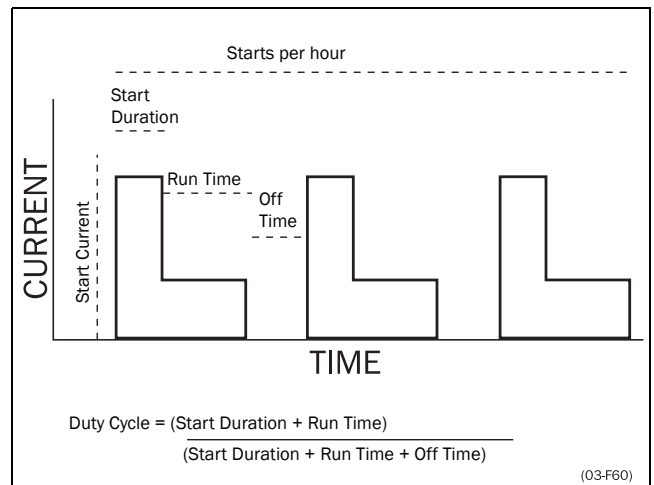

Fig. 28 Duty cycle, non-bypass.

The above example indicates a current rating of 210 Amps with a start current ratio of 5.0 x FLC (1050 A) for 30 seconds with a 50% duty cycle and 10 starts per hour.

NOTE: If more than 10 starts/hour or other duty cycles are needed, please contact your supplier.

In the Applications Rating List two commonly used levels of AC53a are specified. These are also given in the technical data tables (see chapter 13. on page 113).

6.2 Softstarter rating according to AC53b

This norm is made for bypass operation. The MSF 2.0 softstarter is designed to run continuously. In the event of high ambient temperature or for other reasons, an external bypass contactor can be used to minimize the power loss at nominal speed. In the Application Rating List, one level of AC53b is specified, normal with bypass.

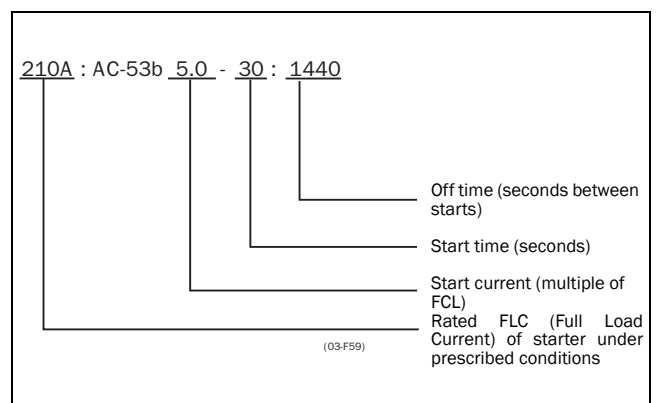

Fig. 29 AC53b rating example.

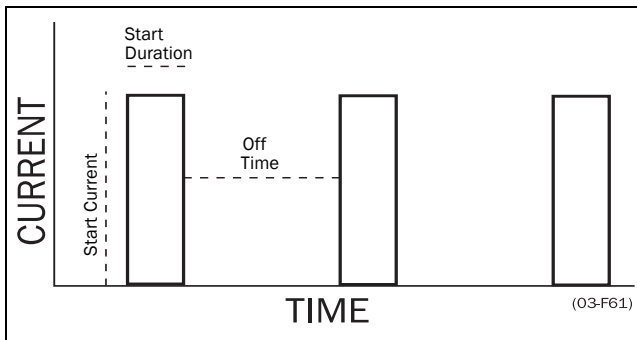

Fig. 30 Duty cycle, bypassed

The above example indicates a current rating of 210 Amps with a start current ratio of 5.0 x FLC (1050 A) for 30 seconds with a 24-minute interval between starts.

6.3 The Applications Rating List

According to the norms AC53a and AC53b a softstarter can have many current ratings.

With help of the Applications Rating List the correct rating can be chosen for most applications.

The Applications Rating List uses two levels for the AC53a norm and one level for the AC53b norm:

AC53a 5.0-30:50-10 (heavy)

This level will be able to start almost all applications and follows directly the type number of the softstarter.

Example: MSF-370 is designed for 370 A full load current (FLC) and 5 times this current for a starting time of 30 seconds.

AC 53a 3.0-30:50-10 (normal)

This level is for lighter applications and here the MSF 2.0 can manage a higher FLC.

Example: MSF-370 can be used for an application with 450 A FLC if the starting current is not more than 3 times this current for a starting time of 30 seconds.

AC53b 3.0-30:330 (normal with bypass)

This level is for lighter applications when a bypass contactor is used. The MSF 2.0 can in this case be used for applications with an even higher nominal current.

Example

An MSF-370 can be used for an application with a full load current of 555 A if the starting current is no more than three times this value and a bypass contactor is used.

NOTE: To compare softstarters it is important to ensure that not only FLC (Full Load Current) is compared but also the starting performance.

The Applications Rating List

The first column in the Applications Rating List, see Table 10, page 33 gives various applications. If the machine or application is not in this list, try to identify a similar machine or application. If in doubt please contact your supplier. The second and third columns gives typical ratings for the machine or application. The ratings are divided in Normal/Normal with by-pass and Heavy duty.

Example

The application is a Roller Mill. From the Applications Rating List a Roller Mill is rated as a Heavy duty application due to high starting current. The proper size of MSF 2.0 has to be selected from the Heavy rating column, see Technical data.

Table 10 Applications Rating List

Applications	Normal AC53a 3.0-30:50-10 and Normal with bypass AC53b 3.0-30:300	Heavy AC 53a 5.0-30:50-10
General & Water		
Centrifugal Pump	X	
Submersible Pump	X	
Conveyor		X
Compressor, Screw	X	
Compressor, Reciprocating	X	
Fan	X	
Blower	X	
Mixer		X
Agitator		X
Metals & Mining		
Belt Conveyor		X
Dust Collector	X	
Grinder	X	
Hammer Mill		X
Rock Crusher		X
Roller Conveyor		X
Roller Mill		X
Tumbler		X
Wire Draw Machine		X
Food Processing		
Bottle Washer	X	
Centrifuge		X
Dryer		X
Mill		X
Palletiser		X
Separator		X
Slicer	X	
Pulp and Paper		
Repulper		X
Shredder		X
Trolley		X
Petrochemical		
Ball Mill		X
Centrifuge		X
Extruder		X
Screw Conveyor		X
Transport & Machine Tool		
Ball Mill		X
Grinder		X
Material Conveyor		X
Palletiser		X
Press		X
Roller Mill		X
Rotary Table		X
Trolley		X
Escalator		X

Table 10 Applications Rating List

Applications	Normal AC53a 3.0-30:50-10 and Normal with bypass AC53b 3.0-30:300	Heavy AC 53a 5.0-30:50-10
Lumber & Wood Products		
Bandsaw		X
Chipper		X
Circular Saw		X
Debarker		X
Planer		X
Sander		X

6.4 The Application Functions List

This list gives an overview of many different applications with their challenges and a possible solution with one of the many MSF 2.0 functions.

Description and use of the table:

Application

This column gives the various applications. If the machine or application is not on this list, try to identify a similar machine or application. If in doubt please contact your supplier.

Challenge

This column describes possible challenges that are familiar for this kind of application.

MSF 2.0 Solution

Gives the possible solution for the challenge using one of the MSF 2.0 functions.

Menus

Gives the menu numbers and selection for the MSF 2.0 function.

"200;=1", means: set parameter [200] to 1.

"323;=1 / 320, 324", means: set parameter [323] to 1, parameters [320] and [324] are related to this function.

Table 11 Application Functions List

Application	Challenge	MSF Solution	Menus
PUMP	Too fast starts and stops	Pre-setting for pump application	300
	Non-linear ramps	Square torque control for square loads.	310;=2, 320;=2
	Water hammer	Square torque control	320;=2
	High current and peaks during starts	Square torque control	310;=2
	Pump is going in wrong direction	Phase reversal alarm	440
	Dry running	Shaft power underload	401
	High load due to dirt in pump	Shaft power overload	400
COMPRESSOR	Mechanical shock for compressor, motor and transmissions	Linear Torque control	310;=1
	Small fuses and low current available.	Linear torque control and current limit at start.	310;=1, 314
	Screw compressor going in wrong direction	Phase sequence alarm	440
	Damaged compressor if liquid ammonia enters the compressor screw.	Shaft power overload	400
	Energy consumption due to compressor running unloaded	Shaft power underload	401
BLOWER	Mechanical shock for blower, motor and transmissions. High start current requires large cables and fuses.	Torque control ensures smooth starts that minimize mechanical stress. Start current is minimized by torque-controlled start.	310;=1

Table 11 Application Functions List

Application	Challenge	MSF Solution	Menus
CONVEYOR	Mechanical shocks for transmissions and transported goods.	Linear torque control	310;=1
	Loading or unloading conveyors	Slow speed and accurate position control.	330-333, 500,501
	Conveyor jammed	Shaft power overload	400
	Conveyor belt or chain is off but the motor is still running	Shaft power underload	401
	Starting after screw conveyor has stopped due to overload.	JOG in reverse direction and then starting in forward.	335, 500
	Conveyor blocked when starting	Locked rotor function	228, 229
FAN	High starting current in end of ramps	Square torque control for square load characteristics	310;=2
	Slivering belts.		
	Fan is going in wrong direction when starting.	Catching the motor and going easy to zero speed and then starting in right direction.	310;=2
	Belt or coupling broken	Shaft power underload	401
Blocked filter or closed damper.			
PLANER	High inertia load with high demands on torque and current control.	Linear torque control gives linear acceleration and low starting current.	310;=1
	Need to stop quickly both for emergency and production efficiency reasons.	Dynamic vector brake without contactor for medium loads.	320;=5 323;=1,324
		Reverse current brake with external contactor for heavy loads.	320;=5 323;=2,324
	High speed lines	Conveyor speed set from planer shaft power analogue output.	520-523
	Worn out tool	Shaft power overload	400
	Broken coupling	Shaft power underload	401
ROCK CRUSHER	High inertia	Linear torque control gives linear acceleration and low starting current.	310;=1
	Heavy load when starting with material	Torque boost	316,317
	Low power if a diesel powered generator is used.	Current limit at start	314
	Wrong material in crusher	Shaft power overload	400
	Vibrations during stop	Dynamic vector brake without contactor	320;=5 323;=1,324
BANDSAW	High inertia load with high demands on torque and current control.	Linear torque ramp gives linear acceleration and low starting current.	310;=1
	Need to stop quickly.	Dynamic vector brake without contactor for medium loads.	320;=5 323;=1,324
		Reverse current brake with external contactor for heavy loads.	320;=5 323;=2,324
	High speed lines	Conveyor speed set from bandsaw shaft power analogue output.	520-523
	Worn out saw blade	Shaft power overload	400
	Broken coupling, saw blade or belt	Shaft power underload	401
CENTRIFUGE	High inertia load	Linear torque control gives linear acceleration and low starting current.	310;=1
	Too high load or unbalanced centrifuge	Shaft power overload	400
	Controlled stop	Dynamic vector brake without contactor for medium loads.	320;=5 323;=1,324
		Reverse current brake with external contactor for heavy loads.	320;=5 323;=2,324
	Need to open centrifuge in a certain position.	Braking down to slow speed and then positioning control.	330-333, 500,501

Table 11 Application Functions List

Application	Challenge	MSF Solution	Menus
MIXER	Different materials	Linear torque control gives linear acceleration and low starting current.	310;=1
	Need to control material viscosity	Shaft power analogue output	520-523
	Broken or damaged blades	Shaft power overload	400
		Shaft power underload	401
HAMMER MILL	Heavy load with high breakaway torque	Linear torque control gives linear acceleration and low starting current.	310;=1
		Torque boost in beginning of ramp.	316,317
	Jamming	Shaft power overload	400
	Fast stop	Reverse current brake with reversing contactor for heavy loads.	320;=5 323;=2,324
	Motor blocked	Locked rotor function	228

Example

Hammer Mill:

- Linear Torque control (parameter [310]=1) will give the best results.
- Torque boost to overcome high breakaway torque (menus [316] and [317])
- Overload alarm function for jamming protection (menu [400])
- Stop function reverse current brake (menu [323], selection 2) can be used. Menus 324 and [325] to set the brake time and strength.

6.5 Special conditions

6.5.1 Small motor or low load

The minimum load current for the MSF 2.0 softstarter is 10% of the rated current of the softstarter, except for the MSF-017 where the min. current is 2 A. Example: MSF-210, rated current = 210 A. Min. Current 21 A. Please note that this is “minimum load current” and not minimum rated motor current.

6.5.2 Ambient temperature below 0°C

For ambient temperatures below 0°C an electric heater or similar must be installed in the cabinet. The softstarter can also be mounted somewhere else since the distance between the motor and the softstarter is not critical.

6.5.3 Phase compensation capacitor

If a phase compensation capacitor is to be used, it must be connected at the inlet of the softstarter, not between the motor and the softstarter.

6.5.4 Shielded motor cable

It is not necessary to use shielded wires together with softstarters. This is due to the very low radiated emissions.

NOTE: The softstarter should be wired with a shielded control cable to fulfil the EMC regulations outlined section 1.6, page 6.

6.5.5 Pump control with softstarter and frequency inverter together

It is possible, e.g. in a pump station with two or more pumps, to use one frequency inverter on one pump and softstarters on each of the other pumps. The flow of the pumps can then be controlled by one common control unit.

6.5.6 Starting with counter-clockwise rotating loads

It is possible to start a motor clockwise, even if the load and motor are rotating counterclockwise e.g. fans. Depending on the speed and the load “in the wrong direction” the current can be very high.

6.5.7 Running motors connected in parallel

When starting and running motors connected in parallel, the total amount of the motor current must be equal or lower than the rating of the connected softstarter. Please note that it is not possible to have individual settings for each motor or to use the internal thermal motor protection. The start ramp can only be set for an average starting ramp for all the connected motors. This means that the start time may differ from motor to motor.

For motors connected in parallel, torque control is not recommended because of the risk of oscillation between the motors. Voltage control with or without current limit is preferred instead. The use of the braking functionality is not recommended for motors connected in parallel.

6.5.8 Running motors linked together

When starting and running motors mechanically linked together but with one softstarter connected to each motor, there are two kinds of operation available. The first is to start the motors at the same time using voltage control with or without current limit. The second is to start one motor first with torque or voltage control and after the motor has reached full speed, the voltage to the other motors is ramped up using voltage control.

6.5.9 Step-up transformer for high voltage motor

A step-up transformer can be used between the MSF and the motor for controlling a motor rated at high voltage (e.g. higher than 690 V). Torque control can be used for starting and stopping. To compensate for the step-up transformer magnetization current at start, the initial torque should be set a little higher than normal. The motor data must be recalculated for the lower voltage side of the transformer.

6.5.10 How to calculate heat dissipation in cabinets

See chapter 13. on page 113 “Technical Data”, “Power loss at rated motor load”, “Power consumption control card” and “Power consumption fan”. For further calculations please contact your local supplier of cabinets, e.g. Rittal.

6.5.11 Insulation test on motor

When testing the motor with high voltage e.g. insulation test, the softstarter must be disconnected from the motor. This is due to the fact that the softstarter will be seriously damaged by the high peak voltage.

6.5.12 Operation above 1000 m

All ratings are stated at 1000 m over sea level.

If an MSF 2.0 is placed at 3000 m for example, it must be derated.

To get information about motors and drives at higher altitudes please contact your supplier to get technical information no 151.

6.5.13 Aggressive environment conditions

In some aggressive environments e.g. sewage plants and pump stations with high concentration of hydrogen sulphide it is recommended to use softstarters equipped with coated boards (for ordering information see chapter 1.5 on page 6). Coating of the boards minimizes the risk for corrosion and therefor increases the lifetime of the softstarter.

6.5.14 IT earthing system

Distribution systems may be build up with IT earthing system, which allows for one earth fault to occur without interruption of operation. For use in these systems, MSF 2.0 softstarters should be ordered with IT-net option. The control supply input of the MSF 2.0 softstarters can be configured for normal or IT-net connection by adjusting a jumper (for more information see chapter 12.5 on page 111). With the IT-net option, outer measures on the mains supply are required to fulfil EMC-regulations. The same applies for the control supply if the jumper is set for IT-net.

6.5.15 Earth fault relay

It is possible to use an earth fault relay to protect motor and cables (not for human safety). To avoid undesired tripping due to filter capacitor charging currents, choose a short-time delayed residual current device rated 300 mA.

7. Operation of the softstarter



Fig. 31 MSF softstarter models MSF-017 to MSF-1400.

7.1 General description of user interface



WARNING!
Never operate the softstarter with the front cover removed.

To obtain the required operation, a number of parameters must be set in the softstarter.

Configuration is carried out either from the control panel or by a computer/control system through the serial communication interface (option). Controlling the motor i.e. start/stop, selection of parameter set, is done either from the control panel, through the remote control inputs or through the serial communication interface (option).

Setting



WARNING!
Make sure that all safety measures have been taken before switching on the power supply.

Switch on the control supply (normally 1*230 V); all segments in the display will be illuminated for a few seconds. Then the display will show menu [100]. An illuminated display indicates that there is control supply voltage to the softstarter.

Check that you have voltage on the mains contactor or on the thyristors. Set the motor data, menus [210] to [215], to achieve correct functionality and optimized performance of the build-in functions such as torque control, motor protection, shaft power monitor etc.

7.2 Control panel

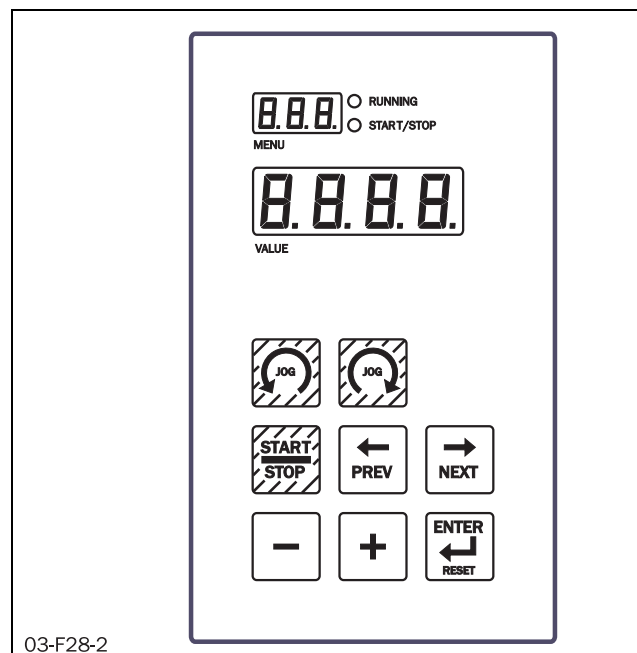

Fig. 32 Control panel.

The control panel is used for selection, configuration and presentation. It consists of:

- 2 light emitting diodes (LEDs).
- 1 display with three 7-segment digits showing the actual menu number.
- 1 display with four 7-segment digits showing the actual value.
- Keyboard with eight keys.

7.3 LED indication

The two light emitting diodes indicate start/stop and running motor/machine.

When a start command is given either from the control panel, through the serial communication interface (option) or through the remote control inputs, the start/stop LED will be illuminated. At a stop command the start/stop LED will switch off. The start/stop LED flashes when the softstarter is in standby operation waiting for a start caused by Auto reset or analogue start/stop.

When the motor is running, the running LED flashes during ramp up and down and is illuminated continuously at full motor voltage.

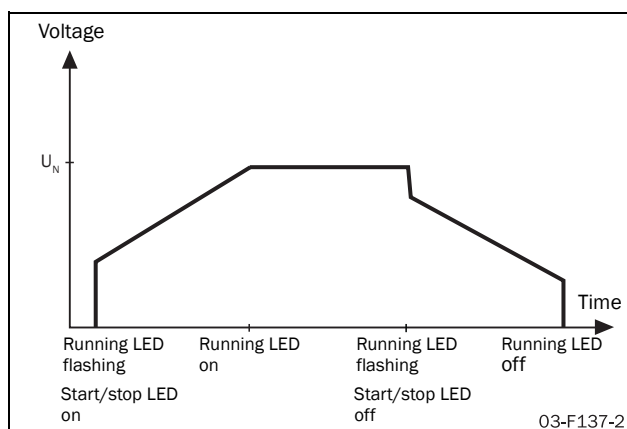

Fig. 33 LED indication at different operation situations.

7.4 The menu structure

The menus in MSF 2.0 are organized in a 1-level structure and they are divided into the groups set out in table 8.

For easier commissioning the menus are divided into three groups, Read-out, Setting and Multi Setting. Read-out menus are only for reading; Setting menus are for setting one parameter and Multi Setting menus are for setting several parameters which cannot be undone. The menus are selected by navigating backwards and forwards through the menu system. Sub-menus simplify setting but are not available when the corresponding main function is not activated.

Table 12 Menu structure of MSF 2.0.









Function	Menu number
General settings	100-101, 200-202
Motor data	210-215
Motor protection	220-231
Parameter set handling	240-243
Auto reset	250-263
Serial communication	270-273
Operation settings	300-342
Process protection	400-440
I/O settings	500-534
View operation	700-732
Alarm list	800-814
Softstarter data	900-902

7.5 The keys

The function of the control panel is based on a few simple rules.

1. At power up menu [100] is shown automatically.
2. Use the “NEXT →” and “PREV ←” keys to move between menus. To scroll through menu numbers, press and hold either the “NEXT →” or the “PREV ←” key.
3. The “+” and “-” keys are used to increase respectively decrease the value of setting. The value is flashing during setting.
4. The “ENTER ↵” key confirms the setting just made, and the value will go from flashing to stable.
5. The “START/STOP” key is only used to start and stop the motor/machine.
6. The and keys are only used for JOG from the control panel. The JOG function must be enabled in menu [334] or [335].

Table 13 The keys

Start/stop motor operation.	
Display previous menu.	
Display next menu.	
Decrease value of setting.	
Increase value of setting.	
Confirm setting just made. Alarm reset.	
JOG Reverse	
JOG Forward	

7.6 Control panel lock

The control panel can be locked to prevent parameter being set by unauthorised personnel.

- Lock control panel by simultaneously pressing both “NEXT →” and “ENTER ↵” for at least 2 sec. The message ‘- Loc’ will be displayed for 2 seconds when locked.
- To unlock control panel, simultaneously press the same 2 keys “NEXT →” and “ENTER ↵” for at least 2 sec. The message ‘unlo’ will be displayed for 2 seconds when unlocked.

In locked mode it is possible to operate the softstarter from the control panel and to view all parameters and read-outs, but it is not possible to change any parameters.

7.7 Overview of softstarter operation and parameter set-up

Table showing how parameters can be set and operation carried out.

Table 14 Control sources

Control source	Control panel lock	Operation		Setting of parameters
		Start/Stop	Alarm reset	
Control panel Parameter [200]=1	Unlocked control panel	Control panel	Control panel	Control panel
	Locked control panel	Control panel	Control panel	-----
Remote Parameter [200]=2	Unlocked control panel	Remote	Remote and control panel	Control panel
	Locked control panel	Remote	Remote and control panel	-----
Serial comm. Parameter [200]=3	Unlocked control panel	Serial comm.	Serial comm. and control panel	Serial comm.
	Locked control panel	Serial comm.	Serial comm. and control panel	Serial comm.

NOTE: If external control of parameter set is chosen in menu [240] no parameters except for parameter set [249] and control source [200] can be changed.

8. Functional description

This functional description for Softstarter MSF 2.0 describes the menus and parameters in the softstarter unit. You will find a short description of each function, their aims and settings.

The MSF 2.0 provides extensive setting possibilities via menus on the control panel, remote control or serial communication. The menus are numbered according to the menu overview in Table 11.

Table 15 Menu overview

Function	Menu number	Description	See section
General settings	100-101 200-202	General basic settings.	8.1
Motor data	210-215	For insertion of technical data for the actual motor.	8.2
Motor protection	220-231	Protection associated with the motor in the application.	8.3
Parameter set handling	240-243	Selection and configuration of parameter sets.	8.4
Auto reset	250-263	Automatic reset of active alarm and restart of MSF 2.0.	8.5
Serial communication	270-273	Serial communication settings for the data transfer.	8.6
Operation settings	300-342	Settings associated with the operation, for example the start- and stop procedures.	8.7
Process protection	400-440	Protection associated with the process.	8.8
I/O settings	500-534	In- and output settings for control and monitoring.	8.9
View operation	700-732	For read-out of measured values.	8.10
Alarm list	800-814	Latest error. Available alarms.	8.11
Softstarter data	900-902	Displays softstarter type, software variant and version.	8.12

8.1 General settings

General settings for MSF 2.0 contains the following menus:

[100] Current

[101] Automatic return menu

[200] Control source

[201] Control panel locked for settings

[202] Enable US units

8.1.1 Current [100]

This read-out menu shows the actual current to the motor.

100	Read-out
Current	
0.0	
Range:	0.0-9999A

NOTE: This is the same read-out as menu [700].

8.1.2 Automatic return menu [101]

When the MSF 2.0 is powered up, menu [100] (Current read-out) is shown as default. When another menu has been selected by the user (moving through the menu list with the “NEXT” or “PREV” keys) this menu will remain active. Alternatively a specific menu can be chosen as automatic return menu. The chosen menu will be shown automatically after 60 seconds without any control panel activity.

101	Setting
Automatic return menu	
OFF	
Default:	oFF
Range:	oFF, 1-999
oFF	Automatic return menu is disabled.
1-999	Automatic return menu.

8.1.3 Control source [200]

The softstarter can be controlled either via the control panel, remote control or the serial communication interface. Remote control via terminals 11,12 and 13 is the default setting.

NOTE: Depending on the setting in this menu, the softstarter may be configured via control panel or via serial communication. See Table 14, page 42 for more information.

NOTE: If control panel (1) or remote control (2) is configured, the setting can only be changed via control panel to serial communication control (3). However, if serial communication control (3) is configured, the setting can be changed either via serial communication or via control panel.

200	Setting
Control source	
2	
Default:	2 (remote control)
Range:	1, 2, 3
1	Control panel.
2	Remote control.
3	Serial communication control.

8.1.4 Control panel lock [201]

The MSF 2.0 Control panel can be locked to prevent parameter being set by unauthorised personnel.

- Lock control panel by simultaneously pressing both keys “NEXT →” and “ENTER ←” for at least 2 seconds. The message “- Loc” will be displayed for 2 seconds.
- To unlock control panel, simultaneously press the same two keys “NEXT →” and “ENTER ←” for at least 2 seconds. The message “unlo” will be displayed for 2 seconds.

In locked mode, all parameters and read-out menus can be displayed, but it is forbidden to change any parameters via the control panel.

The message “-Loc” will be displayed if someone tries to set a parameter in locked mode.

The key lock status can be read out in menu [201].

NOTE: If parameter [200] is configured for serial communication control, the softstarter may still be configured via serial communication, regardless of the control panel lock status.

201	Read-out
Control panel locked for settings	
OFF	
Default:	no
Range:	oFF, on
no	Control panel is not locked
YES	Control panel is locked

8.1.5 Enable US units [202]

By default all read-out and configuration values are given in SI units. If preferred, US customary units can be chosen instead. In this case the following units are used:

- Powers are set and shown in HP, menus [212] and [703]
- Shaft torque is shown in lbft, menu [705]
- Temperature is shown in degrees Fahrenheit, menu [707]

NOTE: When the setting for US units is changed, the motor data in menus [210-215] is reset to the default values for the chosen units (SI or US customary units) in all parameter sets.

[210] Nominal motor voltage – new default value (460 V, for US units enabled)

[211] Nominal motor current – new default value depending on softstarter size.

[212] Nominal motor power – new default value depending on softstarter size

[213] Nominal motor speed – new default value depending on softstarter size

[215] Nominal frequency – new default value (60 Hz, for US units enabled)

If the setting is changed and confirmed with “ENTER”, “SEt” is displayed for 2 seconds to indicate successful selection.

202 ^o		Setting
Enable US units		
OFF		
Default:	OFF	
Range:	OFF, ON	
OFF	Values are presented in kW, Nm etc.	
ON	Values are presented in HP, lbft etc.	

8.2 Motor data

For optimal performance the MSF 2.0 softstarter should be configured according to the motor’s rating plate:

[210] to [215] Nominal motor data

NOTE: The default factory settings are for a standard 4-pole motor according to the nominal current and power of the softstarter. The softstarter will run even if no specific motor data is selected, but the performance will not be optimal.

Nominal motor voltage.

210 ^o		Setting
Nominal motor voltage		
400		
Default:	400 V	
Range:	200-700 V	
200-700	Nominal motor voltage.	

NOTE: Make sure the softstarter’s maximum voltage rating is suitable for selected motor voltage.

Nominal motor current. The current range is related to the size of the softstarter.

211 ^o		Setting
Nominal motor current		
17		
Default:	I _{nsoft} in A	
Range:	25-200% of I _{nsoft} in A	
25-200	Nominal motor current	

Nominal motor power in kW or HP. The power range is related to the size of the softstarter.

212 ^o		Setting
Nominal motor power		
7.5		
Default:	P _{nsoft} in kW	
Range:	25-400% of P _{nsoft} in kW or HP.	
25-400	Nominal motor power.	

Nominal motor speed.

<div style="display: flex; justify-content: space-between; align-items: center;"> 213 ^o Setting </div>	
Nominal motor speed	
<div style="border: 1px solid black; padding: 5px; display: inline-block;"> 1 4 5 0 </div>	
Default:	N _{nsoft} in rpm
Range:	500-3600 rpm
500-3600	Nominal motor speed.

Nominal motor power factor.

<div style="display: flex; justify-content: space-between; align-items: center;"> 214 ^o Setting </div>	
Nominal power factor	
<div style="border: 1px solid black; padding: 5px; display: inline-block;"> 0. 8 6 </div>	
Default:	0.86
Range:	0.50-1.00
0.50-1.00	Nominal motor power factor.

Nominal motor frequency

<div style="display: flex; justify-content: space-between; align-items: center;"> 215 ^o Setting </div>	
Nominal frequency	
<div style="border: 1px solid black; padding: 5px; display: inline-block;"> 5 0 </div>	
Default:	50 Hz
Range:	50 Hz, 60 Hz
50, 60	Nominal frequency.

8.3 Motor protection

The MSF 2.0 softstarter is equipped with different motor protection functions. The following menus are available to configure these protection methods:

[220]-[223] Thermal motor protection

[224]-[227] Start limitation

[228]-[229] Locked rotor

[230] Single phase input failure

[231] Current limit start time expired

For these protection methods the following options are available (all options may not be available for all protection methods – check the description of the relevant menu for details):

Off

The protection method is disabled.

Warning

The appropriate alarm message is shown in the display and relay K3 is activated (for default configuration of the relays). However, the motor is not stopped and operation continues. The alarm message will disappear and the relay will be reset when the fault disappears. The alarm may also be reset manually.

Coast

The appropriate alarm message is shown in the display and relay K3 is activated (for default configuration of the relays). The motor voltage is automatically switched off. The motor freewheels until it stops.

Stop

The appropriate alarm message is shown in the display and relay K3 is activated (for default configuration of the relays). The motor is stopped according to the stop settings in menus [320] to [325].

Alarm Brake

The appropriate alarm message is shown in the display and relay K3 is activated (for default configuration of the relays). The brake function is activated according to the braking method chosen in menu [323] and the motor is stopped according to the alarm brake settings in menus [326] to [327] (braking strength and braking time).

8.3.1 Thermal motor protection

With MSF 2.0 an internal thermal model of the motor or an external signal from a PTC can be used for thermal motor protection. It is also possible to combine both protection methods. Slight overload for a long time and several overloads of short duration will be detected with both methods.

Thermal motor protection [220]

Thermal motor protection is activated by choosing an alarm action in menu [220]. After that menus [221] to [223] will be available so that the type of the protection (internal and/or PTC) can be chosen. If the operation has been interrupted due to a thermal motor protection alarm, a manual reset and a new start signal is needed to restart the motor. The reset and the start signal can be given via control panel, remote or via serial communication depending on the control source chosen in menu [200]. Regardless of the chosen control source, it is always possible to initiate a reset via the control panel.

NOTE: A reset via the control panel will never start the motor.

220 ^o		Setting
<div style="border: 1px solid black; display: inline-block; padding: 2px;"> 2 </div> Thermal motor protection (Alarm code F2)		
Default:	2 (Coast)	
Range:	oFF, 1, 2, 3, 4	
oFF	Thermal motor protection is disabled.	
1	Warning	
2	Coast	
3	Stop	
4	Alarm Brake	

PTC input [221]

This menu is available if thermal motor protection is enabled in menu [220]. To use the PTC functionality, connect the PTC to terminals 69 and 70. See fig. 53. If the motor gets too warm (PTC resistance above 2.4 kOhm), an F2 alarm will occur. The alarm will remain active until the motor has cooled down (PTC resistance below 2.2 kOhm).

221 ^o		Setting
<div style="border: 1px solid black; display: inline-block; padding: 2px;"> o F F </div> PTC input		
Default:	oFF	
Range:	oFF, on	
oFF	Motor PTC input is disabled.	
on	Motor PTC input is enabled.	

NOTE: Open terminals will give an F2 alarm immediately. Make sure the PTC is always connected or the terminals are shorted.

Internal protection class [222]

This menu is available if thermal motor protection is enabled in menu [220]. In this menu an internal protection class can be chosen, which enables internal thermal motor protection. With this setting a thermal curve as set out in Fig. 34 is configured. The motor's thermal capacity is calculated continuously based on the chosen curve. If the thermal capacity exceeds 100% an F2 alarm occurs and the action chosen in menu [220] is performed. The alarm remains active until the motor model cools down to 95% of its thermal capacity. The used thermal capacity is shown in menu [223].

222 ^o		Setting
<div style="border: 1px solid black; display: inline-block; padding: 2px;"> 1 0 </div> Internal protection class		
Default:	10 s	
Range:	oFF, 2-40 s	
oFF	Internal protection class is disabled.	
2-40	Selection of the thermal curve as set out in Fig. 34.	

NOTE: Check that the motor current is configured properly in menu [211].

NOTE: If an external bypass contactor is used, check that the current transformers are placed and connected correctly.

CAUTION!
 **Used thermal capacity is set to 0 if the control board loses its supply (terminal 01 and 02). This means that the internal thermal model starts with a "cold" motor, which perhaps in reality is not the case. This means that the motor can be overheated.**

Used thermal capacity [223]

This menu is available if thermal motor protection is activated in menu [220] and an internal protection class is chosen in menu [222]. The menu shows the thermal capacity of the motor according to the thermal curve chosen in menu [222].

223 ^o		Read-out
<div style="border: 1px solid black; display: inline-block; padding: 2px;"> 0 </div> Used thermal capacity		
Range:	0-150%	

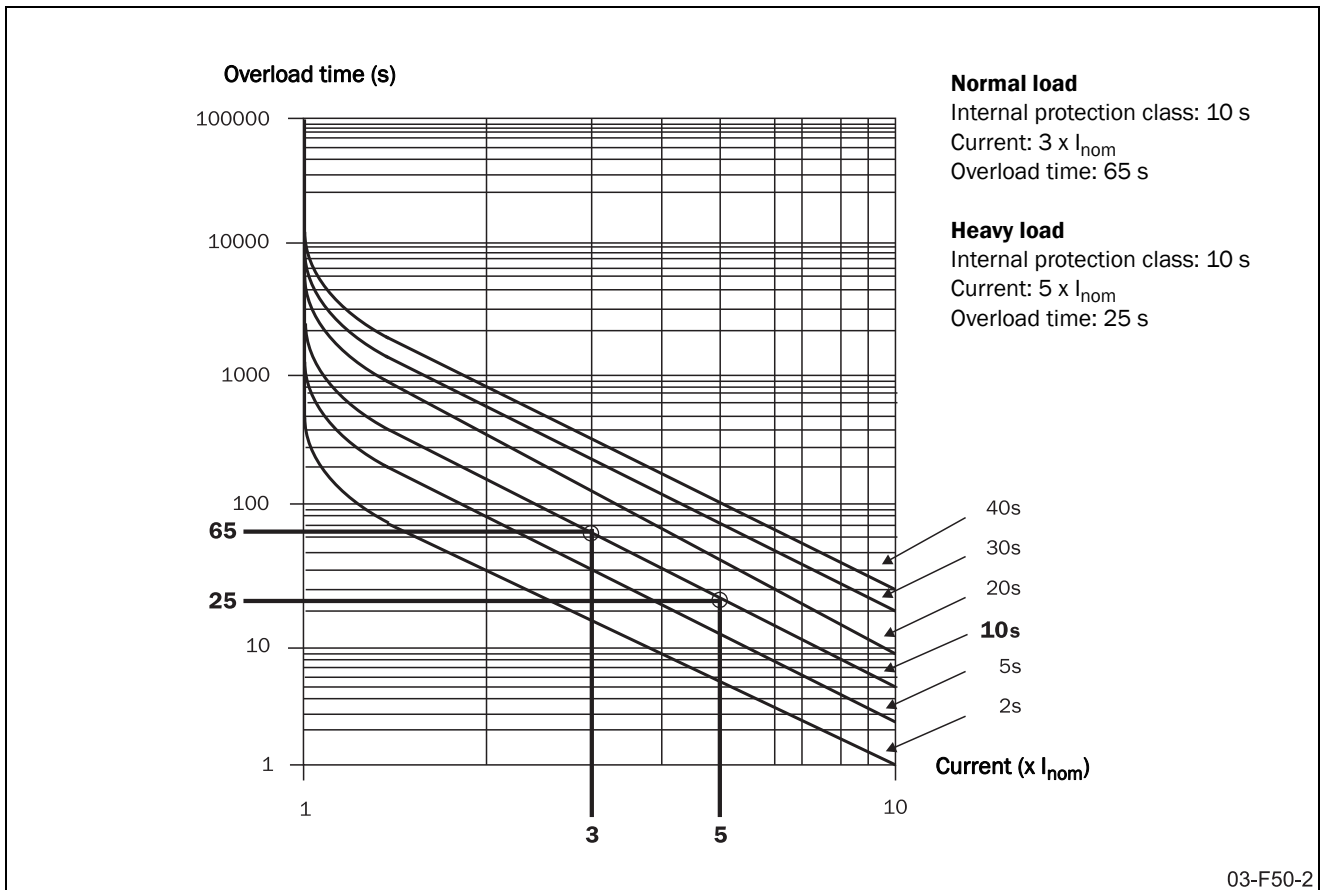

Fig. 34 The thermal curve

8.3.2 Start limitation

Start limitation is used to protect the motor by limiting the numbers of starts per hour or securing a minimum time delay between starts. Both protection methods can be used separately or in combination.

Start limitation [224]

Start limitation is enabled in this menu by choosing a proper alarm action. The available options are:

Off

The protection method is disabled.

Warning

Alarm message F11 is shown in the display and relay K3 is activated (for default configuration of the relays). However, the start will be allowed.

Coast

Alarm message F11 is shown in the display and relay K3 is activated (for default configuration of the relays). The start will not be allowed.

A Start limitation alarm is automatically reset when a new start signal is given. The start signal can be given via control panel, remote or via serial communication depending on the control source chosen in menu [200]. Regardless of the

chosen control source, it is always possible to initiate a reset via the control panel.

NOTE: A reset via the control panel will never start the motor.

224 ^o / _o		Setting
o F F		Start limitation (Alarm code F11)
Default:	oFF	
Range:	oFF, 1, 2	
oFF	Start limitation is disabled.	
1	Warning	
2	Coast	

Number of starts per hour [225]

This menu is available if start limitation is enabled in menu [224]. In this menu the allowed number of starts per hour is configured. If this number is exceeded, an F11 alarm occurs and the action chosen in menu [224] is performed. The alarm is active until the hour has expired and a new start can be allowed.

225 ^o		Setting
Number of starts per hour		
o F F		
Default:	oFF	
Range:	oFF, 1-99	
oFF	Starts per hour protection is disabled	
1-99	Number of starts per hour.	

Min. time between starts [226]

This menu is available if start limitation is enabled in menu [224]. In this menu a minimum time between consecutive starts can be configured. If a new start attempt is made before the configured minimum time is expired an F11 alarm will occur and the action chosen in menu [224] is performed. The alarm remains active until the chosen minimum time has expired and a new start can be allowed.

226 ^o		Setting
Min. time between starts		
o F F		
Default:	oFF	
Range:	oFF, 1-60 min	
oFF	Min. time between starts protection is disabled.	
1-60	Min. time between starts.	

Time to next allowed start [227]

This menu is available if start limitation is enabled in menu [224] and at least one of the protection methods described above is configured (number of starts per hour or minimum time between starts). In this menu the remaining time to the next allowed start is shown. If both protection methods mentioned above are activated, the shown time is the total time delay to the next start, which is allowed by both methods.

227 ^o		Read-out
Time to next allowed start		
0		
Range:	0- 60 min	

8.3.3 Locked rotor

This alarm is used to avoid high motor current due to a mechanically locked rotor. If the operation has been interrupted due to a locked rotor alarm, a manual reset and a new start signal is needed to restart the motor. The reset and the start signal can be given via control panel, remote or via serial communication depending on the control source chosen in menu [200]. Regardless of the chosen control source, it is always possible to initiate a reset via the control panel.

NOTE: A reset via the control panel will never start the motor.

Locked rotor [228]

Locked rotor alarm is activated in this menu by choosing a proper alarm action.

228 ^o		Setting
Locked rotor alarm (Alarm code F5)		
o F F		
Default:	oFF	
Range:	oFF, 1, 2	
oFF	Locked rotor alarm is disabled.	
1	Warning	
2	Coast	

Locked rotor time [229]

This menu is available if Locked rotor alarm is enabled in menu [228]. In this menu the time delay for detection of a locked rotor is configured. If a high motor current (4.8 times the nominal motor current) is floating for a time exceeding the chosen value, an F5 alarm will occur and the action chosen in menu [228] will be performed.

229 ^o		Setting
Locked rotor time		
5.0		
Default:	5.0 s	
Range:	1.0-10.0 s	
1.0-10.0	Locked rotor time.	

NOTE: Check that the motor current is configured properly in menu [211].

Single phase input failure [230]

The softstarter's action on a single phase input failure occurring during full voltage running can be configured in this menu. In the event of a single phase input failure, alarm F1 is activated after 2 s (see description above) and the chosen action is performed. The alarm remains active until the failure disappears.

230 ^o		Setting
Single phase input failure (alarm code F1)		
2		
Default:	2	
Range:	1, 2	
1	Warning	
2	Coast	

8.3.4 Phase input failure

All phase input failures shorter than 100 ms are ignored.

Multiple phase input failure

If the failure duration time is above 100 ms, operation is temporary stopped and a new soft start is made if the failure disappears within 2 s. If the failure duration time is longer than 2 s an F1 alarm occurs and the voltage to the motor remains off. During deceleration, regardless of the failure duration time, the motor voltage is automatically switched off and the motor freewheels until it stops.

Single phase input failure

During acceleration and deceleration the behaviour is the same as described above for multiple phase input failure. When running with full voltage, the softstarter can be configured for different actions in the event of a single phase input failure (menu [230]).

A phase input failure alarm is automatically reset when a new start signal is given. The start signal can be given via control panel, remote or via serial communication depending on the control source chosen in menu 200. Regardless of the chosen control source, it is always possible to initiate a reset via the control panel.

NOTE: A reset via the control panel will never start the motor.

8.3.5 Current limit start time expired

If current limit at start is activated in menu [314], an F4 alarm can be activated if the operation is still at current limit when the configured start time has expired. A current limit start time expired alarm is automatically reset when a new start signal is given. The start signal can be given via control panel, remote or via serial communication depending on the control source chosen in menu [200]. Regardless of the chosen control source, it is always possible to initiate a reset via control panel.

NOTE: A reset via the control panel will never start the motor.

Current limit start time expired [231]

In this menu the alarm for current limit start time expired can be enabled and a proper action can be selected.

<div style="display: flex; justify-content: space-between; align-items: center;"> 231 <small>o</small> Setting </div>	
<div style="display: flex; justify-content: space-around; align-items: center;"> <div style="border: 1px solid black; padding: 5px;"> 2 </div> <div> <p>Current limit start time expired (alarm code F4)</p> </div> </div>	
Default:	2
Range:	oFF, 1, 2, 3, 4
oFF	Current limit start time expired protection is disabled.
1	Warning
2	Coast
3	Stop
4	Alarm Brake

NOTE: If the action for current limit start time expired is configured as Warning or the protection is not activated at all, the softstarter will ramp up to full voltage with a ramp time of 6 s if the start time has expired in current limit mode. The current is then no longer controlled.

8.4 Parameter set handling

The use of different parameter sets can be helpful when using one softstarter to start different motors or when working under various load conditions. There are four parameter sets available in MSF 2.0. Parameter set handling is controlled by the following parameters:

- [240] Select parameter set
- [241] Actual parameter set
- [242] Copy parameter set
- [243] Reset to factory setting

8.4.1 Select parameter set [240]

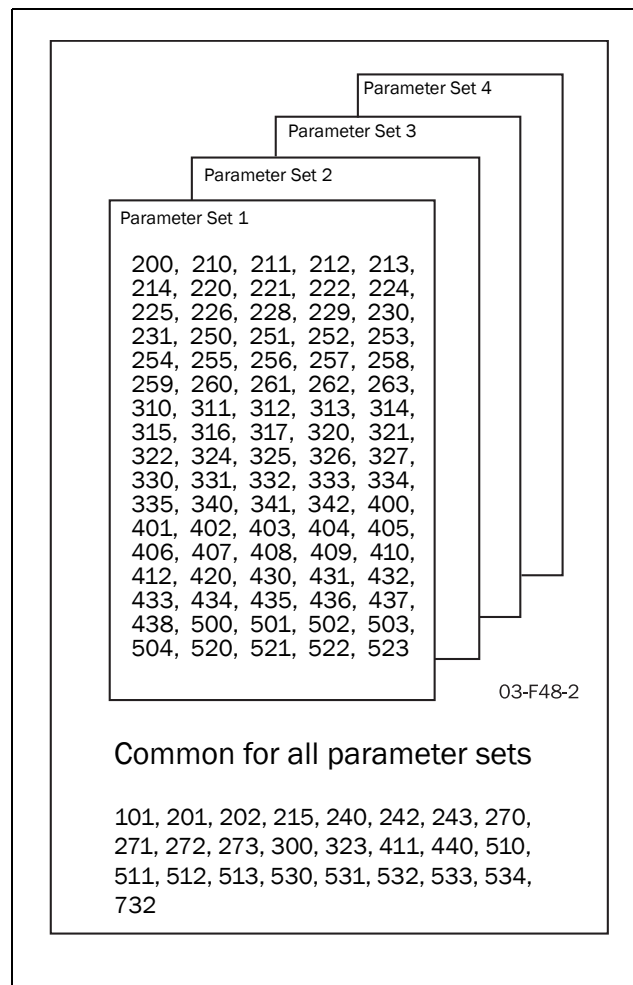

Fig. 35 Parameter overview

Select parameter set [240]

In this menu one of the parameter sets 1-4 can be selected directly or external control of parameter sets via digital inputs can be chosen. If external control of parameter sets is chosen, the digital inputs have to be configured properly (see description of menus [510] to [513]). By default digital inputs 3 and 4 (terminals 16 and 17) are configured for external control of parameter sets.

240 ^o		Setting
Select parameter set		
1		
Default:	1	
Range:	0, 1, 2, 3, 4	
0	External control of parameter sets.	
1, 2, 3, 4	Selection of parameter sets 1-4.	

Actual parameter set [241]

This menu is available when external control of parameter sets is chosen in menu [240]. This menu shows which parameter set is actually selected via the digital inputs.

241 ^o		Read-out
Actual parameter set		
1		
Range:	1, 2, 3, 4	

8.4.2 Copy parameter set [242]

This function will simplify configuration of different parameter sets. It is possible to copy an already configured parameter set into another set as follows:

- Select a copy alternative in this menu, for example P1-2. Press “ENTER”. “CoPY” is displayed for 2 seconds to indicate successful copy process. After that, “no” is displayed.
- Go to menu [240] and select parameter set 2.
- Make the required new settings in corresponding menus for parameter set 2.

242 ^o		Multi Setting
Copy parameter set		
no		
Default:	no	
Range:	no, P1-2, P1-3, P1-4, P2-1, P2-3, P2-4, P3-1, P3-2, P3-4, P4-1, P4-2, P4-3	
no	No action	
P1-2 etc.	Copy parameter set 1 to parameter set 2 etc.	

NOTE: Copying parameter sets is only allowed when the softstarter is not running.

8.4.3 Reset to factory setting [243]

In this menu all parameters can be reset to the default values. This includes all four parameter sets and the common parameters except for parameter [202] (enable US units). As Enable US units is not reset to default, the values loaded for the normal motor data in menus [210] to [215] correspond to the chosen units (SI or US customary), see description of menu [202] on page 45 for more information. The alarm list, the power consumption and the operation time will not be affected by resetting the parameters. When the reset of all parameters to the factory default values has been executed successfully, menu [100] is shown on the display.

243 ^o		Multi Setting
Reset to factory settings		
no		
Default:	no	
Range:	no, YES	
no	No action	
YES	Reset all parameters to the factory default values.	

NOTE: Reset to factory settings is not allowed when the softstarter is running.

8.5 Auto reset

For several non-critical application-related failure conditions, it is possible to automatically generate a reset and initiate a restart to overcome the fault condition. Auto reset functionality is configured using the following parameters:

[250] Auto reset attempts.

[251] to [263] Auto reset items.

In menu [250] the maximum number of automatically generated restarts allowed can be set. When this number is exceeded and a new fault occurs, the softstarter will stay in fault condition because external assistance is required. In menus [251] to [263], auto reset is enabled for the different protection types by choosing a delay time. If a fault occurs for which auto reset is enabled, the motor is stopped according to the action chosen for the relevant protection method (see menus [220] to [231] and [400] to [440] for description of protection methods and configuration of actions on failures). When the fault has disappeared, and the configured delay time has elapsed, the motor is restarted.

Example:

The motor is protected by internal thermal protection. When a thermal protection alarm occurs, the softstarter should wait until the motor is cooled down enough before resuming normal operation. When this problem occurs several times in a short period of time, external assistance is required.

The following settings should be applied:

- Activate thermal motor protection, e.g. set parameter [220] to 2 (Coast).
- Activate internal thermal motor protection, e.g. set parameter [222] to 10 (thermal curve for 10 s).
- Insert maximum number of restarts: e.g. set parameter [250] to 3.
- Activate thermal motor protection to be automatically reset: e.g. set parameter [251] to 100.
- Configure one of the relays to give an alarm when external assistance is required: e.g. set parameter [532] to 19 (all alarms which need manual reset).

The Auto reset functionality is not available if control panel is chosen as control source in menu [220].



WARNING!
A flashing start/stop LED indicates standby mode e.g. waiting for auto reset. The motor may be started automatically at a moment's notice.

NOTE: The auto reset cycle will be interrupted when a stop signal is given (remote or via serial communication) or if the control source is changed to control panel in menu [200].

8.5.1 Auto reset attempts [250]

In this menu the maximum allowed number of automatically generated restart attempts is set. If any number of auto reset attempts is selected in this menu the Auto reset functionality is activated and menus [251] to [263] will become available. If an alarm occurs for which auto reset is enabled (in menus [251] to [263]), the motor will automatically be restarted when the fault has disappeared and the delay time has expired. For each automatically generated restart, the internal auto reset counter (not visible) will go up one place. If no alarm occurs for more than 10 minutes, the auto reset counter will be decreased by one. When the maximum number of auto reset attempts is reached, no further restart will be allowed and the softstarter will remain in fault condition. In this case a manual reset (either via control panel, remote or serial communication, see description on page 39) is needed.

Example:

- Auto reset attempts (parameter [250]=5)
- Within 10 minutes 6 alarms occur.
- At the 6th trip there is no auto reset, because the auto reset counter contains already 5 auto reset attempts.
- To reset, apply a normal reset. This will also reset the auto reset counter.

NOTE: The internal auto reset counter is reset to zero if a stop signal is given. After each new start signal (via remote or serial communication) the maximum number of restart attempts will be allowed as configured in menu [250].

250		Setting
OFF		Auto reset attempts
Default:	oFF	
Range:	oFF, 1-10	
oFF	Auto reset disabled.	
1-10	Number of auto reset attempts.	

8.5.2 Auto reset items [251]-[263]

Menus [251] to [263] are available if auto reset is enabled in menu [250]. With these parameters the delay time for auto reset is configured. The delay time starts counting when the fault is gone. When the delay time has elapsed, the alarm will be reset and a restart attempt will automatically be made.

NOTE: Enabling auto reset for an alarm has no effect if the alarm action for the respective alarm is set to oFF or Warning (1).

Thermal motor protection auto reset [251]

This menu is available if auto reset is activated in menu [250]. In this menu the delay time for thermal motor protection auto reset is configured. The delay time starts counting when the fault is gone. This means the internal thermal motor model has to cool down to a thermal capacity of 95% (if internal thermal motor protection is enabled) and the PTC resistance has to go down to 2.2 kOhm (if PTC is enabled), which indicates that the motor has cooled down. When the delay time has elapsed, the alarm will be reset and a restart attempt will automatically be made.

251		Setting
OFF		Thermal motor protection auto reset
Default	oFF	
Range:	oFF, 1-3600 s	
oFF	Thermal motor protection auto reset is disabled	
1-3600	Delay time for thermal motor protection auto reset	

Start limitation auto reset [252]

This menu is available if auto reset is activated in menu [250]. In this menu the delay time for an auto reset after a start limitation alarm (alarm code F11) is configured. The delay time starts counting when the fault is gone. This means the minimum time between starts has to be expired (if Minimum time between starts protection is enabled) and a start has to be allowed for the actual hour (if starts per hour protection is enabled). When the delay time has elapsed, the alarm will be reset and a restart attempt will automatically be made.

Locked rotor alarm auto reset [253]

This menu is available if auto reset is activated in menu [250]. In this menu the delay time for an auto reset after a locked rotor alarm (alarm code F5) is configured. As a locked rotor cannot be detected in stopped state, the delay time starts counting immediately after the alarm action has been executed. When the delay time has elapsed, the alarm will be reset and a restart attempt will automatically be made.

Current limit start time expired auto reset [254]

This menu is available if auto reset is activated in menu [250]. In this menu the delay time for an auto reset after a current limit start time expired alarm (alarm code F4) is configured. As a current limit start time expired fault condition cannot be detected in stopped state, the delay time starts counting immediately after the alarm action has been executed. When the delay time has elapsed, the alarm will be reset and a restart attempt will automatically be made.

Max power alarm auto reset [255]

This menu is available if auto reset is activated in menu [250]. In this menu the delay time for an auto reset after a max power alarm (alarm code F6) is configured. As a max power fault condition cannot be detected in stopped state, the delay time starts counting immediately after the alarm action has been executed. When the delay time has elapsed, the alarm will be reset and a restart attempt will automatically be made.

Min power alarm auto reset [256]

This menu is available if auto reset is activated in menu [250]. In this menu the delay time for an auto reset after a min power alarm (alarm code F7) is configured. As a min power fault condition cannot be detected in stopped state, the delay time starts counting immediately after the alarm action has been executed. When the delay time has elapsed, the alarm will be reset and a restart attempt will automatically be made.

External alarm auto reset [257]

This menu is available if auto reset is activated in menu [250]. In this menu the delay time for an auto reset after an external alarm (alarm code F17) is configured. The delay time starts counting when the fault is gone. This means the external alarm signal input has to be activated. When the delay time has elapsed, the alarm will be reset and a restart attempt will automatically be made.

Phase input failure auto reset [258]

This menu is available if auto reset is activated in menu [250]. In this menu the delay time for an auto reset after a phase input failure (alarm code F1) is configured. As a phase input failure cannot be detected in stopped state, the delay time starts counting immediately after the alarm action has been executed. When the delay time has elapsed, the alarm will be reset and a restart attempt will automatically be made.

Voltage unbalance alarm auto reset [259]

This menu is available if auto reset is activated in menu [250]. In this menu the delay time for an auto reset after a voltage unbalance alarm (alarm code F8) is configured. The delay time starts counting when the fault is gone. Usually, the mains voltage will not be available to the softstarter in stopped state as the mains contactor is deactivated. In this case a voltage unbalance failure cannot be detected in stopped state and the delay time starts counting immediately after the alarm action has been executed. When the delay time has elapsed, the alarm will be reset and a restart attempt will automatically be made.

Over voltage alarm auto reset [260]

This menu is available if auto reset is activated in menu [250]. In this menu the delay time for an auto reset after an over voltage alarm (alarm code F9) is configured. The delay time starts counting when the fault is gone. Usually, the mains voltage will not be available to the softstarter in stopped state as the mains contactor is deactivated. In this case an over voltage failure cannot be detected in stopped state and the delay time starts counting immediately after the alarm action has been executed. When the delay time has elapsed, the alarm will be reset and a restart attempt will automatically be made.

Under voltage alarm auto reset [261]

This menu is available if auto reset is activated in menu [250]. In this menu the delay time for an auto reset after an under voltage alarm (alarm code F10) is configured. The delay time starts counting when the fault is gone. Usually, the mains voltage will not be available to the softstarter in stopped state as the mains contactor is deactivated. In this case an under voltage failure cannot be detected in stopped state and the delay time starts counting immediately after the alarm action has been executed. When the delay time

has elapsed, the alarm will be reset and a restart attempt will automatically be made.

Serial communication auto reset [262]

This menu is available if auto reset is activated in menu [250]. In this menu the delay time for auto reset after a serial communication broken alarm (alarm code F15) is configured. The delay time starts counting when the fault is gone. This means serial communication has to be reestablished. When the delay time has elapsed, the alarm will be reset and a restart attempt will automatically be made.

Softstarter overheated auto reset [263]

This menu is available if auto reset is activated in menu [250]. In this menu the delay time for auto reset after a softstarter overheated alarm (alarm code F3) is configured. The delay time starts counting when the fault is gone. This means the softstarter has to be cooled down. When the delay time has elapsed, the alarm will be reset and a restart attempt will automatically be made.

8.6 Serial communication

There are several serial communication options available for MSF 2.0 (see page 109 for more information). The softstarter can be configured and controlled via serial communication if this is configured in menu [200] (see page 44). The following parameters are available to configure serial communication:

- [270] Serial comm. unit address
- [271] Serial comm. baudrate
- [272] Serial comm. parity
- [273] Serial comm. contact broken

NOTE: The communication parameters [270] to [272] must be set up via the control panel. To enable configuration via the control panel, parameter [200] must be set to 1 (control panel) or 2 (remote control).

Serial comm. unit address [270]

Serial communication unit address.

270 ^o _o		Setting
Serial comm. unit address		
1		
Default:	1	
Range:	1-247	
1-247	Unit address.	

Serial comm. baudrate [271]

Serial communication baudrate.

271 ^o _o		Setting
Serial comm. baudrate		
9.6		
Default:	9.6 kBaud	
Range:	2.4 - 38.4 kBaud	
2.4-38.4	Baudrate.	

Serial comm. parity [272]

Serial communication parity.

272 ^o _o		Setting
Serial comm. parity		
0		
Default:	0	
Range:	0, 1	
0	No parity	
1	Even parity.	

Serial comm. contact broken [273]

If the softstarter is configured for control via serial communications (parameter [200] = 3) and the serial communication contact is broken during operation, an F15 alarm can be configured to occur. In this menu the alarm can be enabled and an action to be performed can be chosen. The following options are available:

Off

Serial communication contact broken alarm is disabled.

Warning

Alarm message F15 is shown in the display and relay K3 is activated (for default configuration of the relays). However, the motor is not stopped and operation continues. The alarm message will disappear and the relay will be reset when the fault disappears. The alarm may also be reset manually from the control panel.

Coast

Alarm message F15 is shown in the display and relay K3 is activated (for default configuration of the relays). The motor voltage is automatically switched off. The motor freewheels until it stops.

Stop

Alarm message F15 is shown in the display and relay K3 is activated (for default configuration of the relays). The motor is stopped according to the stop settings in menus [320] to [325].

Alarm Brake

Alarm message F15 is shown in the display and relay K3 is activated (for default configuration of the relays). The brake function is activated according to the braking method chosen in menu [323] and the motor is stopped according to the alarm brake settings in menus [326] to [327] (braking strength and braking time).

A serial communication broken alarm is automatically reset when a new start signal is given. The start signal can be given via control panel, remotely or via serial communication depending on the control source chosen in menu 200. Regardless of the chosen control source, it is always possible to initiate a reset via control panel.

NOTE: A reset via control panel will never start the motor.

<div style="display: flex; justify-content: space-between; align-items: center;"> <div style="border: 1px solid black; padding: 2px;">273</div> <div style="border: 1px solid black; padding: 2px;">Setting</div> </div>	
<div style="border: 1px solid black; padding: 5px; display: inline-block;"> O F F </div> <p>Serial comm. contact broken (alarm code F15)</p>	
Default:	3
Range:	oFF, 1, 2, 3, 4
oFF	Serial comm. contact broken disabled
1	Warning
2	Coast
3	Stop
4	Alarm Brake

8.7 Operation settings

Operation settings include parameters for configuration of starting and stopping, some of these can be pre-configured for pump applications. Furthermore, some special settings for stop behaviour at alarm, parameters for slow speed and JOG and additional settings such as bypass operation, power factor control and control of the internal fan are included in this section.

[300] Preset pump control parameters

[310]-[317] Start

[320]-[327] Stop including stop at alarm

[330]-[335] Slow speed/JOG

[340]-[342] Additional settings

The MSF Softstarter controls all three phases supplied to the motor. In contrast to a simple softstarter controlling only one or two phases, the three-phase control enables different starting methods, voltage, current and torque control. A current limit can also be used in combination with either voltage or torque control.

With voltage control the output voltage to the motor is linearly increased to full line voltage during the set start time. The softstarter gives a smooth start but does not get any feedback on current or torque. The typical settings to optimize a voltage controlled start are the initial voltage and the start time.

With current control the output voltage to the motor is regulated so the set current limit is not exceeded during the start. With this starting method the starter does not get any feedback on the motor torque either. However, current control can be combined with both voltage and torque control. The typical settings to optimize a current controlled start are the current limit and the maximum starting time.

Torque control is the most sophisticated way of starting motors. The softstarter continually monitors the motor torque and controls the output voltage to the motor so the torque follows the set ramp. Both linear and square torque ramps can be chosen according to the application requirements. In this way constant acceleration can be accomplished during start which is very important in many applications. Torque control can also be used for stopping with constant deceleration. For pumps constant deceleration is important for avoiding water hammer.

8.7.1 Preset pump control [300]

With this multi-setting parameter the MSF 2.0 softstarter can easily be configured for pump applications. The following parameters are set if preset pump control parameters are chosen.

[310] Start method is set to square torque control (2)

[311] Initial torque at start is set to 10%

[312] End torque at start is set to 125%

[315] Start time is set to 10 seconds

[314] and [316] Current limit at start and torque boost are deactivated.

[320] Stop method is set to square torque control (2)

[321] End torque at stop is set to 10%

[325] Stop time is set to 15 seconds.

These settings will lead to a smooth start with linear acceleration and a linear stop without water hammer for most pump applications. However, if the pre-set parameters need to be adapted for a specific application, the values in the relevant menus can be adapted.

The following figure shows typical current characteristics at start and speed curve at stop.

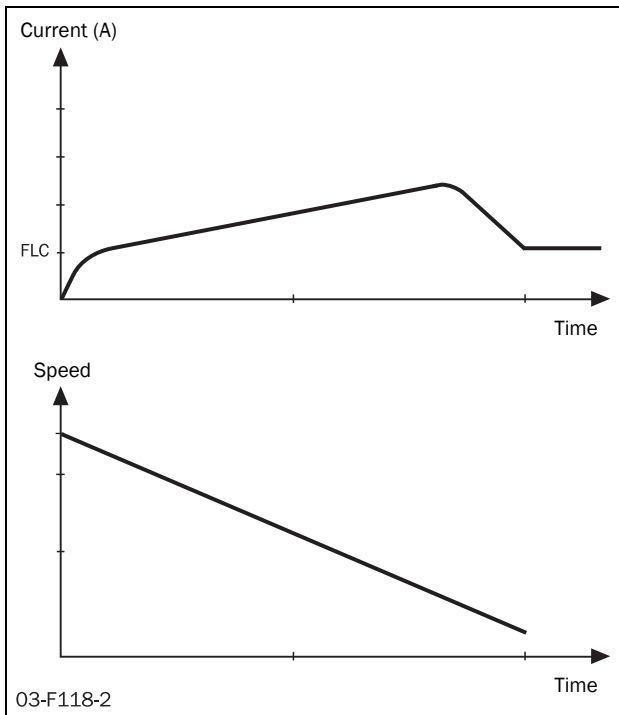

Fig. 36 Pump control. Current at start and speed at stop.

When the pre-setting of the parameters for pump control has been executed successfully, “Set” is shown in the display for two seconds. After that “no” will be shown again.

NOTE: Pre-setting of parameters for pump control is not allowed when the softstarter is running. In this case “SET” is not shown.

300 ^o
Multi Setting

no

Preset pump control parameters

Default:	no
Range:	no, YES
no	No action
YES	Preset parameters for pump control

8.7.2 Start

With MSF 2.0, torque control, voltage control and direct on-line are available as start methods. Torque control is available both for loads with a linear torque characteristic like conveyors and planers and with square torque characteristics for pumps and fans. In general torque control is recommended as a starting method; voltage control may be used when for some special reasons a linear voltage ramp is desired. With Direct on-line (DOL) as a start method, neither the current nor the voltage will be controlled; full voltage is applied to the motor immediately. DOL can be used to start the motor if the softstarter has been damaged and the thyristors are short-circuited.

All start methods can be combined with a current limit. However, only a properly configured torque-controlled start will lead to constant acceleration. For this reason it is not recommended to set a current limit for pump applications. With a proper set-up of the torque control parameters, the starting current will be very low. For applications with variable load characteristics from start to start, the current limit functionality may be useful to avoid overloading the mains fuses. However, as the motor torque is proportional to the square of the current, setting a low current limit will limit the motor torque considerably. If the current limit is set too low in relation to the application's requirements, the motor will not be able to accelerate the load.

Start method [310]

In this menu the start method is chosen. The menus necessary for configuration of the start will be available depending on the chosen start method.

310 ^o
Setting

1

Start method

Default:	1
Range:	1, 2, 3, 4
1	Linear torque control
2	Square torque control
3	Voltage control
4	Direct on-line, DOL

Torque control

The default settings for initial torque at start is 10% and for end torque at start it is 150%. In Fig. 37 the resulting torque curve is shown versus time for linear and square torque characteristics.

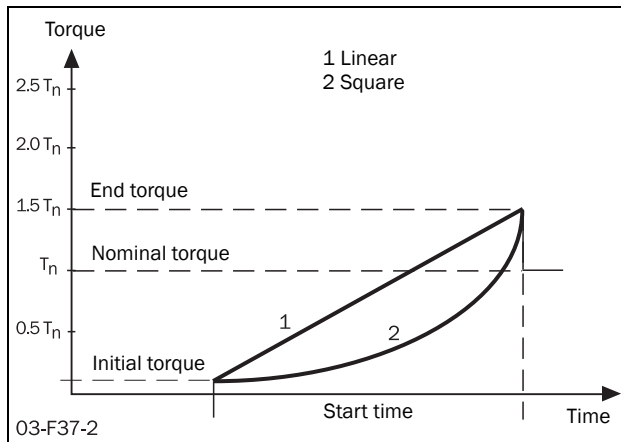

Fig. 37 Torque control at start

A Properly configured torque-controlled start will lead to a linear speed increase and low starting current without current peaks.

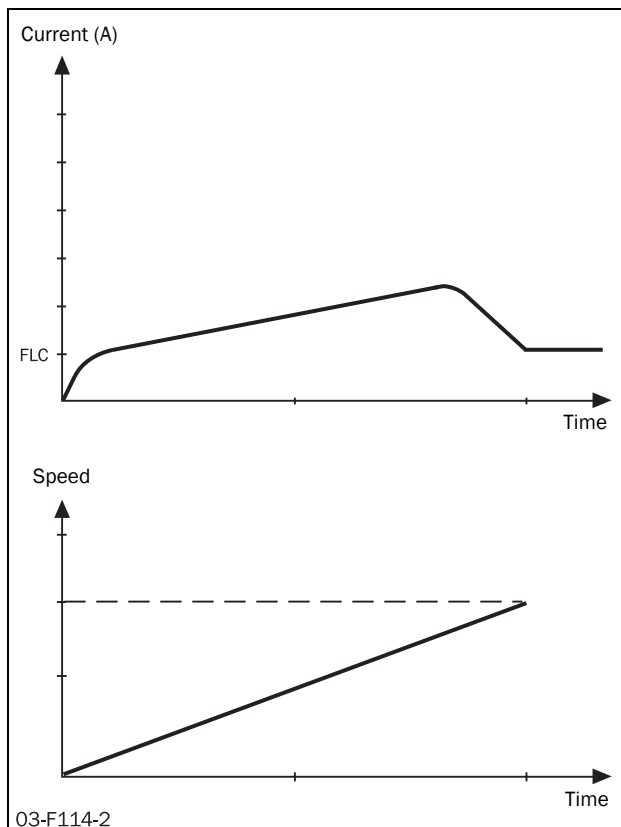

Fig. 38 Current and speed in torque control

To optimize the start, use the setting for initial torque at start, menu [311] and end torque at start, menu [312].

When the start command is given, the motor shaft should immediately start to rotate to avoid unnecessary heat development in the motor. If required, increase the initial torque at start.

The end torque at start should be adjusted so that the time for the motor to come up to nominal speed approximately matches the start time set in menu [315]. If the actual start time is much shorter than the set start time in menu [315], the End torque at start can be decreased. If the motor does not reach full speed before the start time set in menu [315] has expired, the end torque at start has to be increased to avoid current peaks and jerking at the end of the ramp. This may be needed for high inertia loads such as planers, saws and centrifuges.

The read-out of shaft torque in percentage of T_n in menu [706] may be useful for fine-tuning the start ramp.

Initial torque at start [311]

This menu is available if torque control is selected in menu [310]. In this menu the initial torque at start is set.

311 ^o		Setting
Initial torque at start		
10		
Default:	10%	
Range:	0-250% T_n	
0-250	Initial torque at start.	

End torque at start [312]

This menu is available if torque control is selected in menu [310]. In this menu the end torque at start is set.

312 ^o		Setting
End torque at start		
150		
Default:	150%	
Range:	25-250% T_n	
25-250	End torque at start.	

Voltage control

Voltage control can be used when a linear voltage ramp is desired. The voltage to the motor will be ramped up linearly, from initial voltage up to full mains voltage.

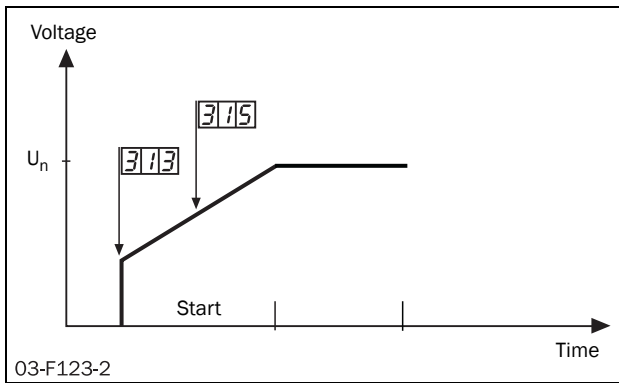

Fig. 39 Menu numbers for initial voltage and start time.

Initial voltage at start [313]

This menu is available if voltage control is chosen as start method in menu [310]. In this menu the initial voltage at start is set.

Setting	
313	
Initial voltage at start	
30	
Default:	30%
Range:	25-90% U
25-90	Sets initial voltage at start.

Direct on-line, DOL

If this alternative is selected in menu [310], the motor can be accelerated as if it was connected directly to the mains.

For this type of operation:

Check whether the motor can accelerate the required load (DOL start). This function can also be used with shorted thyristors.

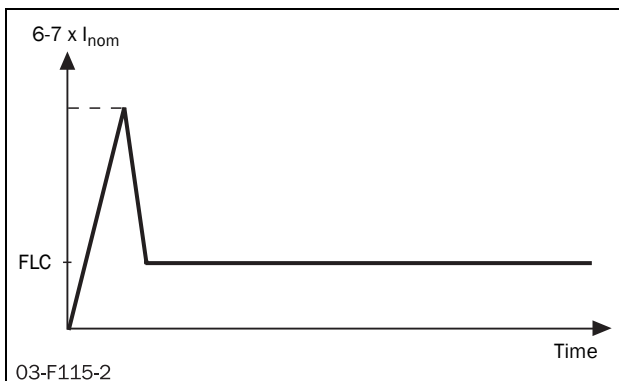

Fig. 40 DOL-start.

Current limit

Current limit at start can be used together with all start methods to limit the current to a defined max level when starting (150-500% of I_n). However, only a properly configured torque-controlled start will lead to linear acceleration. For this reason it is not recommended to set a current limit for pump applications. Moreover, as the motor torque is proportional to the square of the current, setting a low current limit will limit the motor torque considerably. If the current limit is set too low in relation to the application's requirements, the motor will not be able to accelerate the load.

The combination DOL start and current limit at start gives a start ramp with constant current. The softstarter will control the current up to the set current limit immediately at start, and keep it there until the start is completed or the set start-up time expires.

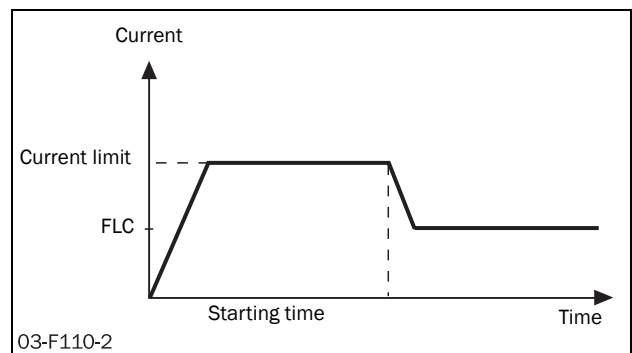

Fig. 41 Direct on-line start in combination with current limit at start.

Current limit at start [314]

In this menu the current limit at start is set.

Setting	
314	
Current limit at start	
OFF	
Default:	oFF
Range:	oFF, 150-500% of I_n
oFF	Current limit disabled.
150-500	Current limit at start.

NOTE: Even though the current limit can be set as low as 150% of the nominal motor current value, this minimum value cannot be used generally. If the current limit is set too low in relation to the application's requirements, the motor will not be able to accelerate the load.

NOTE: Check that the nominal motor current is configured properly in menu [211] if the current limit functionality is used.

If the starting time is exceeded and the softstarter is still operating at current limit, an alarm will be activated according to “Current limit start time expired” settings for motor protection, menu [231]. Operation may be stopped or continued with a pre-defined voltage ramp. Note that the current will rise unchecked if the operation continues.

Start time [315]

In this menu the desired start time is set. This menu is not available if DOL is chosen as a start method and no current limit is configured.

315 ^o		Setting
Start time		
1 0		
Default:	10 s	
Range:	1-60 s	
1-60	Start time.	

Torque boost

In specific applications torque boost is required for the start. The torque boost parameter enables a high torque to be obtained by providing a high current for 0.1-2 seconds at start. This enables a soft start of the motor even if the break away torque is high at start. For example in crushing mills applications etc.

When the torque boost function has finished, starting continues according to the selected start method.

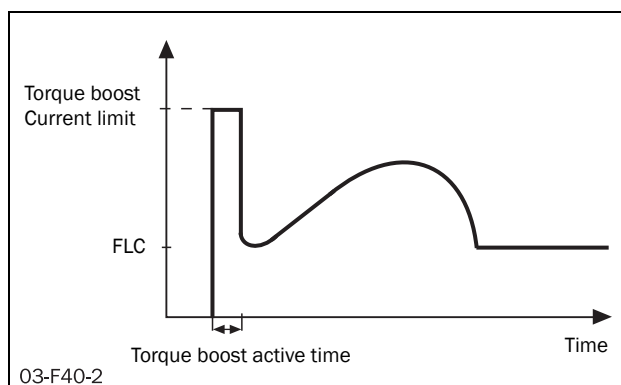

Fig. 42 The principle of the torque boost when starting the motor.

Torque boost current limit [316]

In this menu torque boost is enabled and the current limit for torque boost is configured.

316 ^o		Setting
Torque boost current limit		
3 0 0		
Default:	oFF	
Range:	oFF, 300-700% of I_n	
oFF	Torque boost disabled	
300-700	Torque boost current limit.	

Torque boost active time [317]

This menu is available if torque boost is enabled in menu [316]. In this menu the time for the torque boost to be active is selected.

317 ^o		Setting
Torque boost active time		
O F F		
Default:	1.0 s	
Range:	0.1-2.0 s	
0.1-2.0	Torque boost active time.	

NOTE: Check whether the motor can accelerate the load with “Torque boost” without any harmful mechanical stress.

NOTE: Check that the nominal motor current is configured properly in menu [221].

8.7.3 Stop

With MSF 2.0, four stop methods are available: torque control, voltage control, coast and braking. Torque control is available for loads with linear or square torque characteristic. A torque or voltage-controlled stop is used for applications where the motor stopping suddenly could harm the application, e.g. water hammer in pump applications. In general a torque-controlled stop is recommended for these applications. The voltage-controlled stop can be used if a linear voltage ramp is desired. When coast is selected as a stop method, the voltage to the motor will be switched off and the motor will be left freewheeling. Braking may be used in applications where the motor needs to be stopped quickly, e.g. for planers and bandsaws.

Any start method except for direct on-line (DOL) can be combined with any stop method, e.g. torque control can be used at start and brake for stop. The DOL start method can only be combined with coast or brake stop methods.

Stop method [320]

In this menu the stop method is chosen. The menus necessary for configuring the stop will be available depending on the chosen stop method.

320 ^o _o		Setting
Stop method		
4		
Default:	4	
Range:	1, 2, 3, 4, 5	
1	Linear torque control	
2	Square torque control	
3	Voltage control	
4	Coast	
5	Brake	

Torque control

With torque control at stop, the torque to the motor will be controlled from the nominal torque down to the chosen end torque at stop (menu [321]). Examples for the torque ramps for linear and square torque control are shown in Fig. 43. The default value for end torque at stop is 0; this value may be increased if the motor is standing still before the stop is finished to avoid unnecessary heat development in the motor. With the end torque at stop set properly, the motor speed will decrease linearly down to standstill.

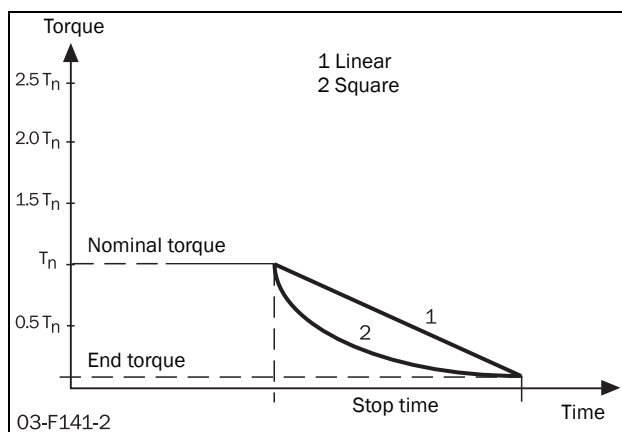

Fig. 43 Torque control at stop

End torque at stop [321]

This menu will be available if torque control is chosen as stop method in menu [320] (alternative 1 or 2). In this menu the end torque at stop is configured.

321 ^o _o		Setting
End torque at stop		
0		
Default:	0%	
Range:	0-100% of T_n	
0-100	End torque at stop.	

Voltage control

With voltage control at stop, the voltage to the motor will be decreased to the chosen step down voltage at stop immediately after a stop signal. Then the voltage to the motor will follow a linear ramp down to the minimum voltage of 25% of the nominal voltage. An example of this voltage ramp is shown in Fig. 44.

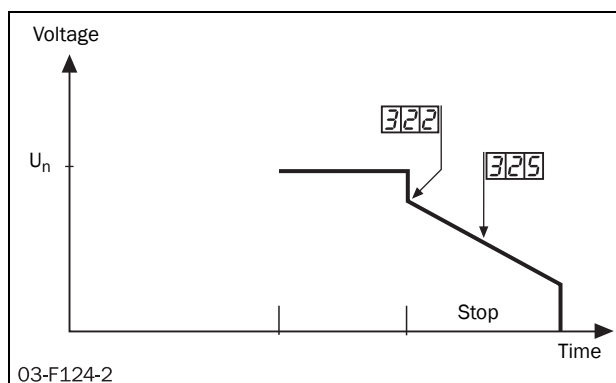

Fig. 44 Menu numbers for step down voltage at stop and stop time.

Step down voltage at stop [322]

This menu is available if voltage control is chosen as stop method in menu [320] (alternative 3). In this menu the step down voltage at stop is chosen in percentage of the nominal motor voltage.

322 ^o _o		Setting
Step down voltage at stop		
1 0 0		
Default:	100%	
Range:	100-40% of U	
100-40	Step down voltage at stop.	

Braking

Braking can be used in applications where there is a need for a quick stop.

There are two built-in braking methods: dynamic vector brake for normal loads and reverse current brake for heavy loads with high inertia. In both braking methods the MSF 2.0 continuously detects the motor speed. At low speed the DC brake mode is activated until the motor is standing still. In DC-brake mode only two phases (L2 and L3) are active.

NOTE: If several softstarters are supplied from the same power line and the braking functionality is used, the softstarters should be connected with different phase sequences, i.e. L1-L2-L3 on the first unit, L2-L3-L1 on the next and so on.

The MSF 2.0 will automatically turn off the output voltage when the motor has stopped or when the stop time has expired. Optionally an external rotation sensor can be connected via digital input, see description for menu [500] on page 78 for more information.

Dynamic vector brake

With dynamic vector brake, the braking torque applied to the motor will increase with decreasing speed. Dynamic vector brake can be used for all loads which are not rotating too close to synchronous speed when the motor voltage is switched off. This is valid for most applications as the load speed usually decreases because of frictional losses in gears or belt drives as soon as the motor voltage is switched off. However, loads with very high inertia may remain at high speed even though the motor is not supplying any torque. For these applications the reverse current brake can be used instead.

When the dynamic vector brake is used, no additional connections or contactors are needed.

Reverse current brake

With reverse current brake, a very high braking torque can be applied to the motor even close to synchronous speed. All kind of loads can be stopped quickly using reverse current brake, including loads with very high inertia. If high braking torques are needed, it should be checked carefully whether the motor, the gear or belt drive and the load can withstand the high mechanical forces. To avoid harmful vibrations, it is generally recommended to select as low a braking torque as possible which also fulfils the demands for a short braking time.

For reverse current brake, two mains contactors are needed. The connection is shown in Fig. 45. The contactors have to be controlled by the MSF's relay outputs. During start and full voltage operation contactor K1 will be activated, for braking K1 will be opened and after a time delay K2 will be activated to change the phase sequence.

NOTE: For several start/stops it is recommend that the motor temperature be monitored using the PTC input.



WARNING!
When reverse current brake is selected, the relays K1 and K2 are automatically configured for reverse current brake functionality. The relay setting remains even if reverse current brake is deactivated. Therefore it may be necessary to adapt the relay functions manually.

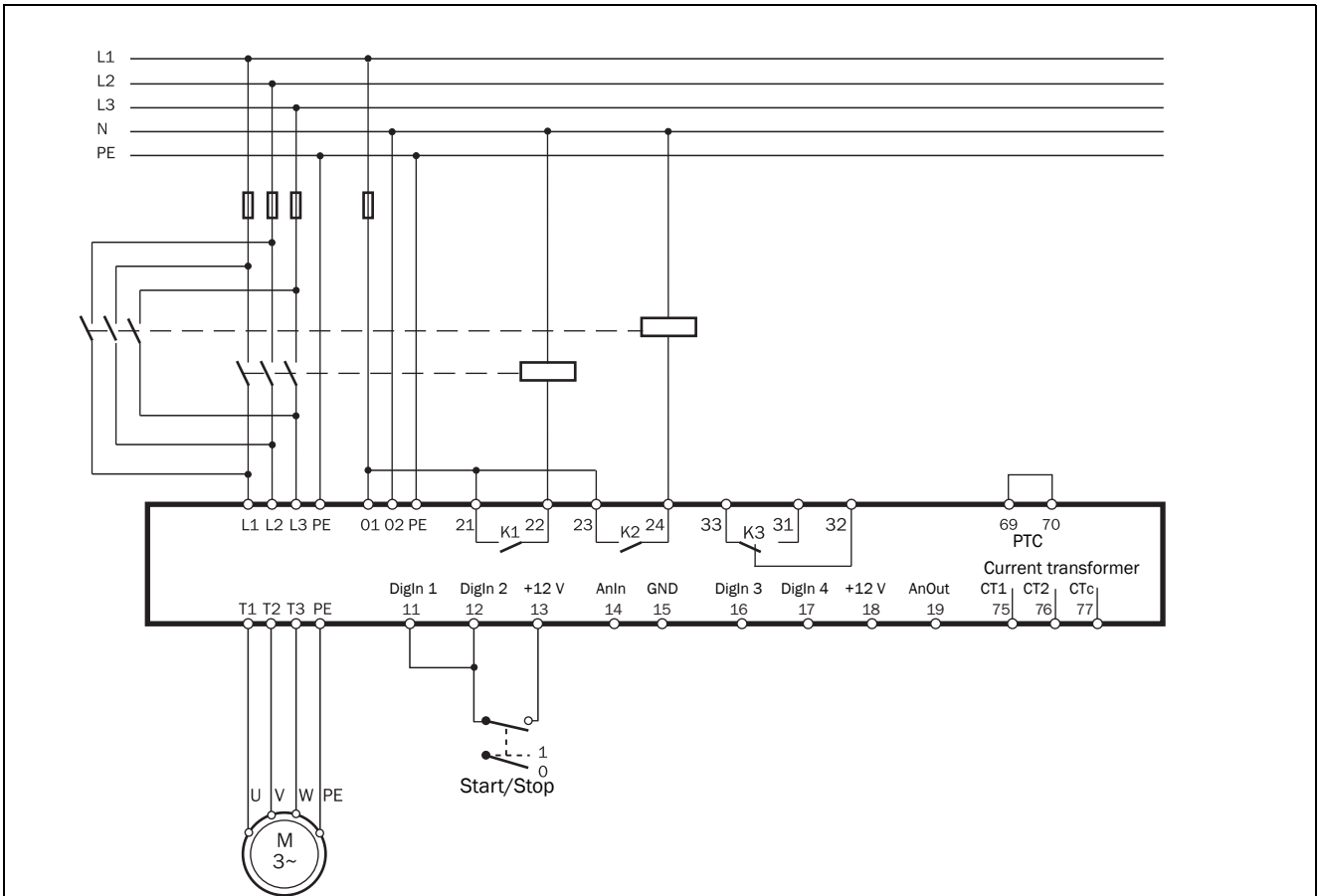

Fig. 45 Reverse current brake wiring example.

Braking method [323]

This menu is available if brake is selected as stop method in menu [320] (alternative 5) or if alarm brake is activated in menu [326] (see description of menus [326] to [327] for more information). In this menu the brake method is selected.

<div style="float: right; border: 1px solid black; padding: 2px;">Setting</div> <div style="float: left; border: 1px solid black; padding: 2px;">323 ^o</div>	
<div style="border: 1px solid black; padding: 5px; display: inline-block;"> 1 Braking method </div>	
Default:	1
Range:	1, 2
1	Dynamic vector brake
2	Reverse current brake

Braking strength [324]

This menu is available if brake is selected as stop method in menu [320] (alternative 5). In this menu the braking strength is selected. To avoid unnecessary heat development in the motor and high mechanical stress it is generally recommended to select as low a braking strength as possible which still fulfils the demands for a short braking time.

<div style="float: right; border: 1px solid black; padding: 2px;">Setting</div> <div style="float: left; border: 1px solid black; padding: 2px;">324 ^o</div>	
<div style="border: 1px solid black; padding: 5px; display: inline-block;"> 150 Braking strength </div>	
Default:	150%
Range:	150-500%
150-500	Braking strength.

Stop time [325]

This menu is available if any stop method except coast is selected in menu [320] (alternative 1, 2, 3 or 5). In this method the desired stop time is selected.

<div style="float: right; border: 1px solid black; padding: 2px;">Setting</div> <div style="float: left; border: 1px solid black; padding: 2px;">325 ^o</div>	
<div style="border: 1px solid black; padding: 5px; display: inline-block;"> 10 Stop time </div>	
Default:	10 s
Range:	1-120 s
1-120	Stop time.

Alarm braking

For most alarms it is possible to configure them so that when they are triggered either operation continues or the motor

stops (see chapter 9, page 99 for more information). Alarm Brake is one of the actions available. If this option is chosen, the braking functionality is activated according to the brake method selected in menu [323] (see description of the braking functionality above for more information). While the braking strength and stop time chosen in menus [324] and [325] are used for braking on a stop signal, different alarm braking strengths and times can be configured in menus [326] and [327] if braking is activated by an alarm. This function may mainly be used in combination with an external alarm (see description on page 74), where an external signal is used to initiate a quick stop with a higher braking strength and a shorter braking time compared to normal operation.

If alarm braking is disabled in menu [326] and alarm brake is chosen as an alarm action, the voltage to the motor will be switched off and the motor will freewheel if the specific alarm occurs.

Alarm braking strength [326]

In this menu braking as an alarm action is enabled and the alarm braking strength is selected. If alarm braking is not activated, the motor will be left freewheeling if an alarm occurs for which alarm brake is configured as alarm action.

<div style="float: right; border: 1px solid black; padding: 2px;">Setting</div> <div style="float: left; border: 1px solid black; padding: 2px;">326 ^o</div>	
<div style="border: 1px solid black; padding: 5px; display: inline-block;"> oFF Alarm braking strength </div>	
Default:	oFF
Range:	oFF, 150-500%
oFF	Coast - motor voltage is switched off.
150-500	Alarm braking strength.

NOTE: If alarm brake is enabled, the braking method chosen in menu [323] is used.

Alarm braking time [327]

This menu is available if alarm brake is enabled in menu [326]. In this menu the braking time to be used in the event of braking as an alarm action is configured.

<div style="float: right; border: 1px solid black; padding: 2px;">Setting</div> <div style="float: left; border: 1px solid black; padding: 2px;">327 ^o</div>	
<div style="border: 1px solid black; padding: 5px; display: inline-block;"> 10 Alarm braking time </div>	
Default:	10 s
Range:	1-120 s
1-120	Alarm braking time.

8.7.4 Slow speed and JOG functions

MSF 2.0 is able to run the motor at a fixed slow speed for a limited period of time. The slow speed will be about 14% of the full speed in the forward direction and 9% in the reverse direction.

NOTE: As the motor torque during slow speed is limited to about 30% of the nominal torque, slow speed can not be used in applications which need a high brake-away torque to start rotating.

The following functions are possible:

Slow speed controlled by an external signal

The time period during which slow speed is active before a start is initiated or after a stop is performed is controlled by an external signal via the analogue/digital input. Slow speed will be active until a selected number of edges has been detected on the input.

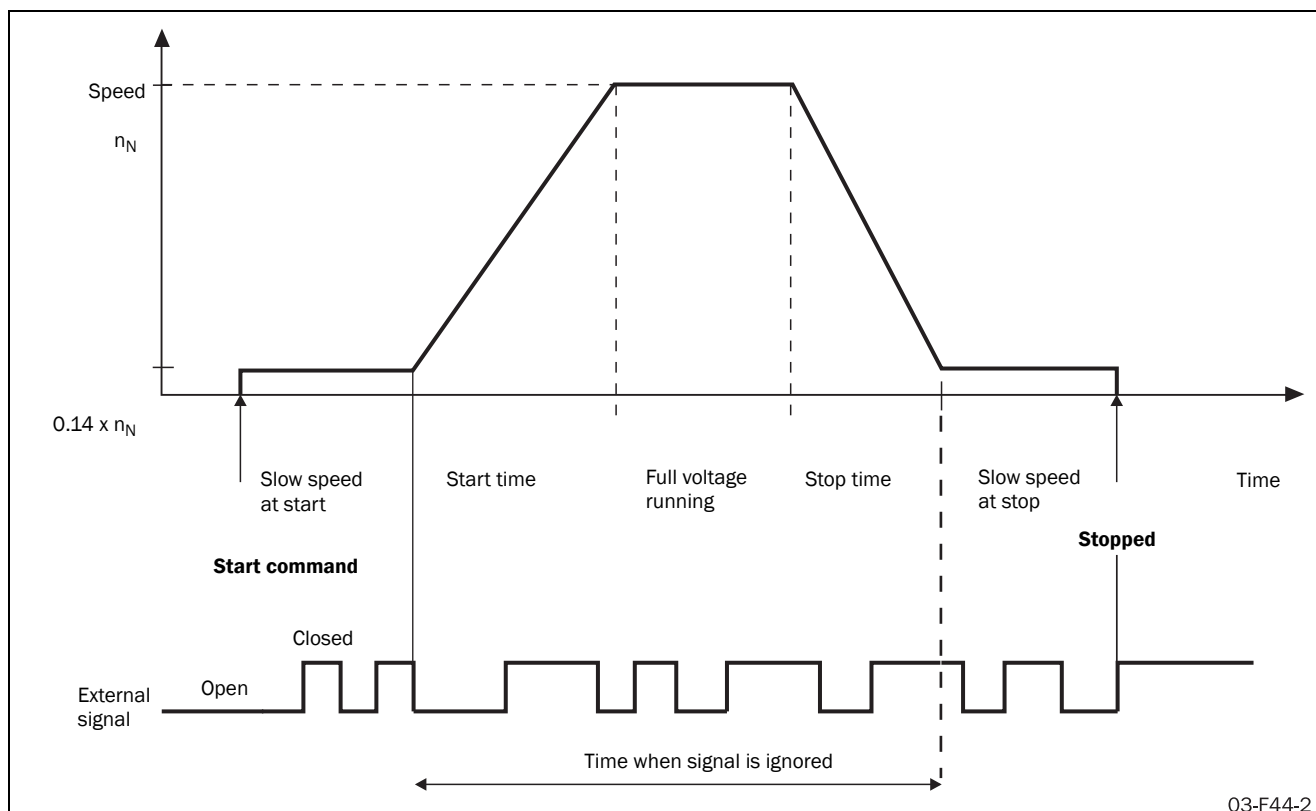

Fig. 46 Slow speed controlled by an external signal.

Slow speed during a selected time period

Slow speed will be active for a selected time period before a start is initiated or after a stop is performed.

Slow speed using the JOG commands

Slow speed can be activated independently from a start or stop via the control panel using the JOG keys, via remote control using the analogue/digital input or via serial communication depending on the control source chosen in menu [200].

Slow speed controlled by an external signal

Slow speed controlled by an external signal is basically the same functionality as slow speed during a selected time described above. An external signal connected to the analogue/digital input is also used to deactivate slow speed before the set time period has expired.

When slow speed at start is configured and the analogue/digital input (menu [500]) is configured for slow speed, the motor shaft will start rotating at slow speed in a forward direction after a start signal. When the number of edges set in menu [501] is detected on the analogue/digital input, slow speed is deactivated and a start is performed according to the start settings (menu [310] and the following).

When slow speed at stop is configured and the analogue/digital input (menu [500]) is configured for slow speed, the motor shaft will start rotating with slow speed in forward direction after a stop has performed. When the number of edges set in menu [501] is detected on the analogue/digital input, slow speed is deactivated and the DC brake is activated if configured in menu [333].

Slow speed controlled by an external signal is configured using the following parameters:

- [500] Digital/analogue input
- [501] Edges digital input
- [330] Slow speed strength
- [331] Slow speed time at start
- [332] Slow speed time at stop

[333] DC-brake at slow speed

[324] Braking strength

Slow speed for a selected time

Slow speed in forward direction can be activated before a start and/or after a stop. The resulting speed curve is shown in Fig. 47 overleaf. Slow speed will be active for the time period selected in menus [331] and [332]. Slow speed can be combined with any start and stop method. However, when slow speed at stop is used, it should be ensured that the motor speed is decreased to a low value when slow speed is activated. If necessary, brake can be activated as stop method in menu [320].

The slow speed strength can be adapted to the application's requirements in menu [330]. Maximum available slow speed strength corresponds to about 30% of nominal motor torque.

If so desired, the DC brake can be activated after slow speed at stop. If activated, the DC brake will be active for the time period chosen in menu [333].

Slow speed during a selected time is configured using the following parameters:

- [330] Slow speed strength
- [331] Slow speed time at start
- [332] Slow speed time at stop
- [333] DC-brake at slow speed
- [324] Braking strength

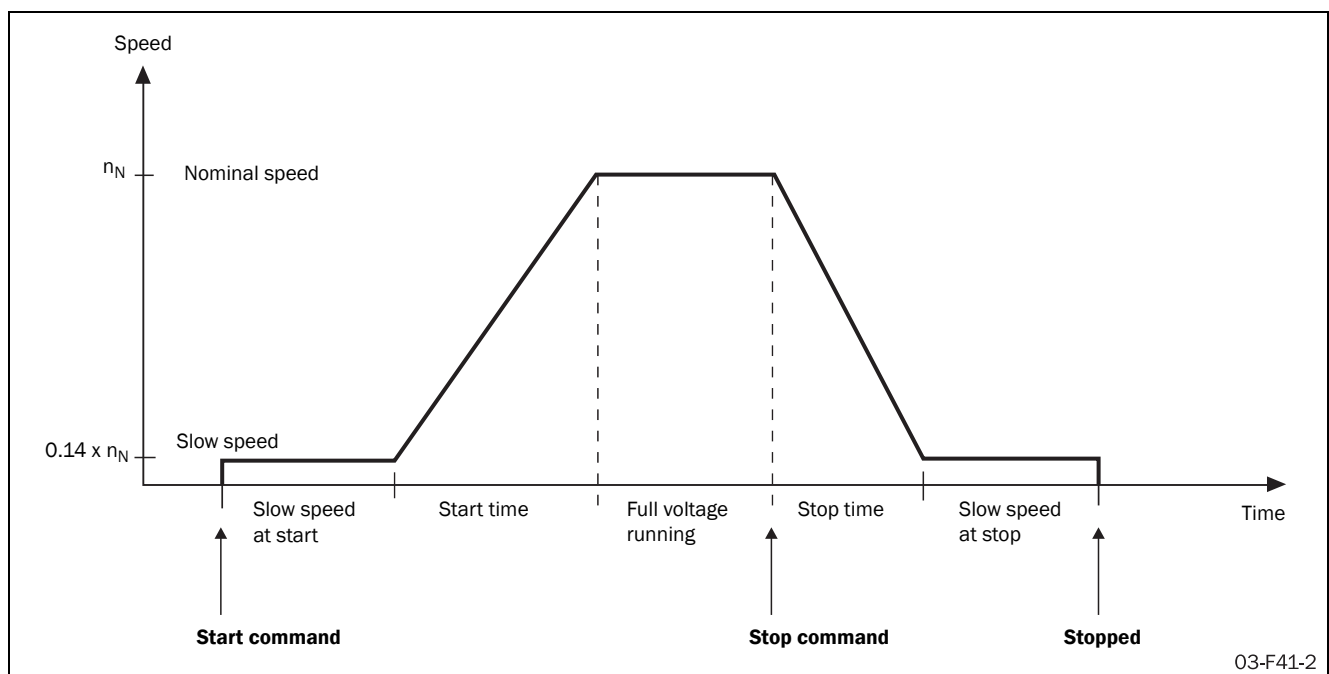

Fig. 47 Slow speed at start/stop during a selected time period.

Slow speed strength [330]

In this menu the slow speed strength is selected. The chosen setting applies for both slow speed during a selected time period, slow speed controlled by an external signal and slow speed using the JOG commands. The maximum setting (100) for the slow speed strength corresponds to about 30% of the nominal motor torque.

330 ^o		Setting
Slow speed strength		
10		
Default:	10	
Range:	10-100	
10-100	Slow speed strength.	

Slow speed time at start [331]

In this menu slow speed at start is activated and the time is set for which slow speed is active before a start. If slow speed at start is controlled by an external signal via the analogue/digital input, the set time becomes the maximum time for which slow speed is activated before a start is performed – if the number of edges set in menu [501] is not detected during the slow speed period.

331 ^o		Setting
Slow speed time at start		
oFF		
Default:	oFF	
Range:	oFF, 1-60 s	
oFF	Slow speed at start is disabled	
1-60	Slow speed time at start.	

Slow speed time at stop [332]

In this menu slow speed at stop is activated and the time is set for which slow speed is active after a stop. If slow speed at stop is controlled by an external signal via the analogue/digital input, the set time becomes the maximum time for which slow speed is activated after a stop – if the number of edges is set in menu [501] is not detected during the slow speed period.

332 ^o		Setting
Slow speed time at stop		
oFF		
Default:	oFF	
Range:	oFF, 1-60 s	
oFF	Slow speed at stop is disabled	
1-60	Slow speed time at stop.	

DC brake at slow speed [333]

In this menu the DC brake can be activated after slow speed at stop. This may be useful for loads with high inertia or if an exact stop position is desired. The DC brake will be active during the time set in this menu. There is no zero speed detection for DC brake after slow speed at stop.

NOTE: The brake strength used for DC brake after slow speed corresponds to the brake strength used for braking as stop method. The braking strength can be adjusted in menu [324].

333 ^o		Setting
DC Brake at slow speed		
oFF		
Default:	oFF	
Range:	oFF, 1-60 s	
oFF	DC brake at slow speed disabled.	
1-60	DC brake duration time at slow speed.	

Slow speed using the JOG commands

Slow speed in forward or reverse direction can be activated using the JOG commands. To use the JOG commands these have to be independently enabled for slow speed in forward or reverse direction in menus [334] and [335]. Depending on the control source chosen in menu [200], the JOG commands are accepted via control panel, remotely via analogue/digital input or via serial communications.

If the control panel is chosen as control source (parameter [200]=1) and the JOG commands are enabled in menus [334] and [335], the JOG keys on the control panel can be

used. Slow speed in forward or reverse direction will be active as long as the relevant button is pushed.

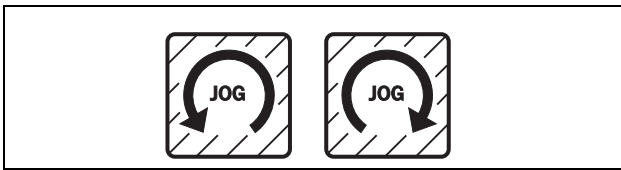

Fig. 48 JOG keys

If remote control is chosen (parameter [200]=2) and the JOG commands are enabled in menus [334] and [335], the JOG commands can be given via analogue/digital input. The analogue/digital input can be configured either for JOG forward or JOG reverse (see description of menu [500] on page 78 for more information). Slow speed will be active as long as the signal on the analogue/digital input is active.

If serial communication control is chosen (parameter [200]=3) and the JOG commands are enabled in menus [334] and [335], the JOG commands can be given via serial communication. (See separate instruction manual for serial communications options.)

JOG forward enable [334]

In this menu the command for JOG in forward direction is enabled. Depending on the control source chosen in menu [200], the JOG forward command may be accepted from the control panel, via remote control or serial communication.

NOTE: The enable functions are for all control sources.

334 ^o		Setting
JOG forward enable		
o F F		
Default:	oFF	
Range:	oFF, on	
oFF	JOG forward disabled	
on	JOG forward enabled	

JOG reverse enable [335]

In this menu the command for JOG in reverse direction is enabled. Depending on the control source chosen in menu

[200,], the JOG reverse command may be accepted from the control panel, via remote control or serial communication.

335 ^o		Setting
JOG reverse enable		
o F F		
Default:	oFF	
Range:	oFF, on	
oFF	JOG reverse disabled	
on	JOG reverse enabled	

8.7.5 Additional settings [340]-[342]

In this section the bypass functionality, power factor control and the control of the internal fan are described.

Bypass [340]

As the MSF 2.0 is designed for continuous running, a bypass contactor is not normally needed. However, where there is high ambient temperature or other special conditions, the use of a bypass contactor can be advantageous. In this case the by-pass contactor can be controlled by one of the relays. By default, relay K2 is configured to control a bypass contactor (for full voltage functionality, see description of menus [530]-[532] on page 86 for more information).

The use of a bypass contactor can be combined with any start and stop method without any connection changes being necessary. However, to use the motor protection functions, the shaft power monitor and the viewing functions in bypassed state, the current transformers have to be moved outside the softstarter. For this purpose an optional extension cable is available, see chapter 12. page 109 (Options) for more information. Figures 49 - 51 below show a connection example.

If a bypass contactor is used, bypass operation must be enabled in menu [340] for the softstarter to work properly.

340 ^o		Setting
Bypass		
o F F		
Default:	oFF	
Range:	oFF, on	
oFF	Bypass disabled	
on	Bypass enabled.	



CAUTION!

If the current transformers are not moved outside the softstarter, several alarm functions will not work properly.

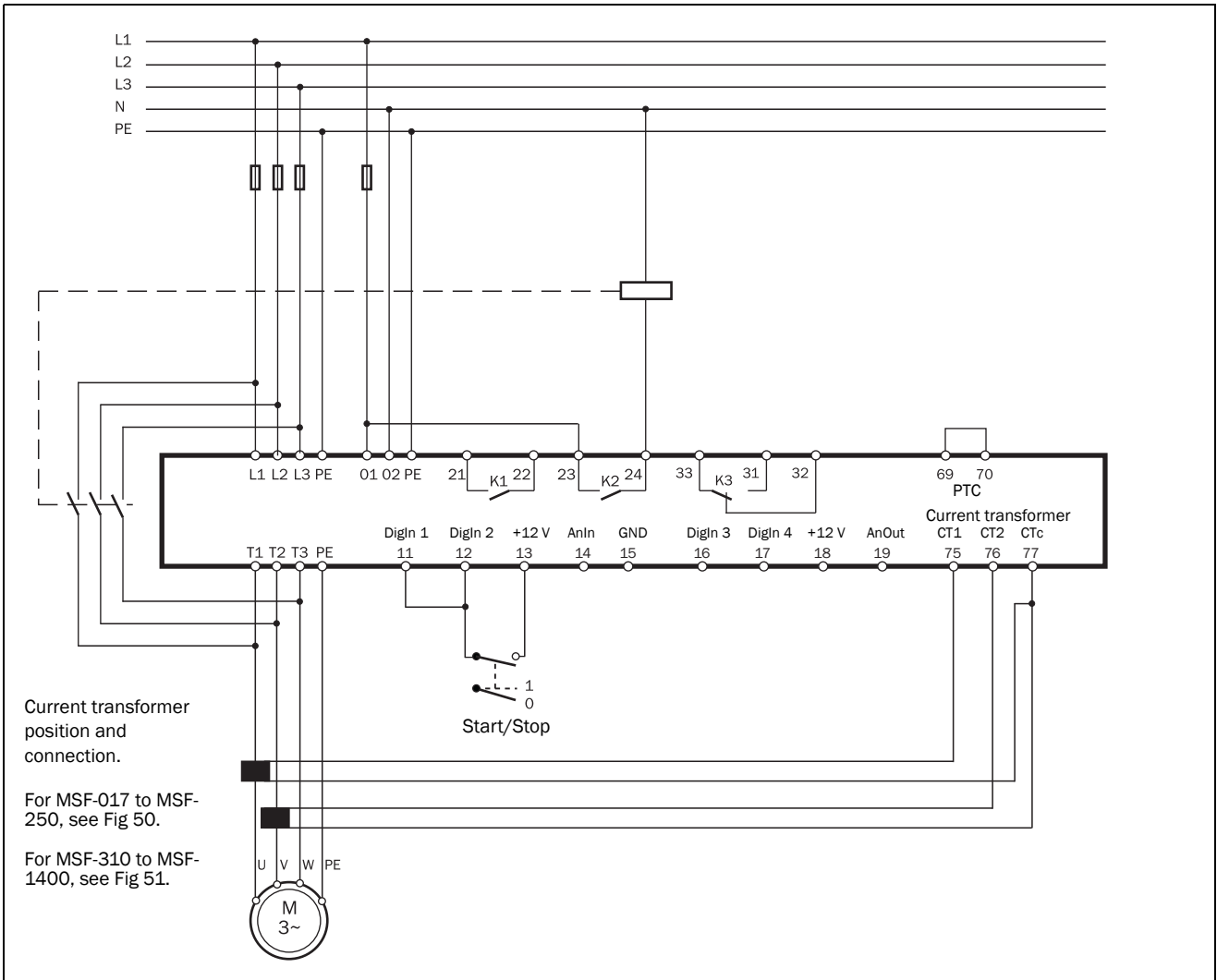

Fig. 49 Bypass wiring example MSF 310-1400.

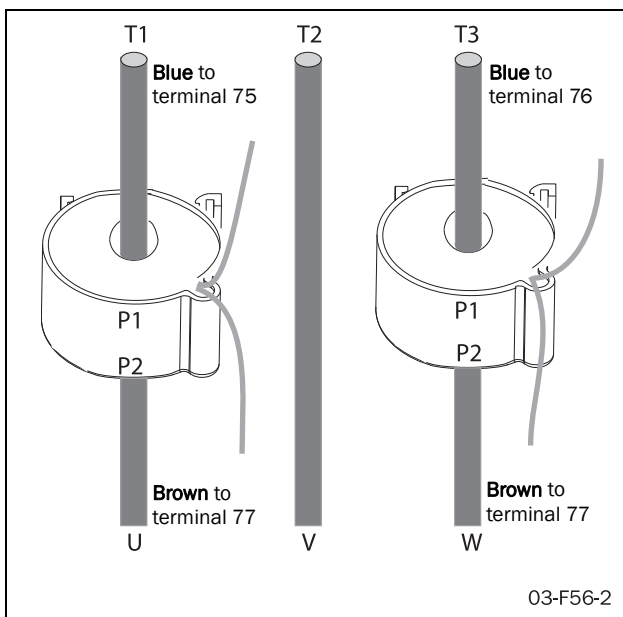

Fig. 50 Current transformer position for Bypass on MSF-017 to MSF-250.

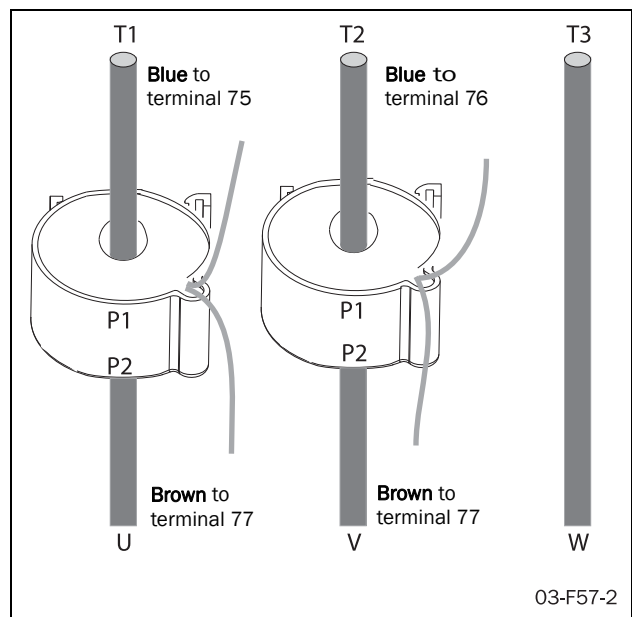

Fig. 51 Current transformer position for Bypass on MSF-310 to MSF-1400.

Power Factor Control PFC [341]

During operation, the softstarter continuously monitors the load of the motor. Particularly when idling or when only partially loaded, it is sometimes desirable to improve the power factor. If Power Factor Control (PFC) is selected, the softstarter reduces the motor voltage when the load is lower. Power consumption is reduced and the degree of efficiency improved.

341 ^o		Setting
Power Factor Control PFC		
o F F		
Default:	oFF	
Range:	oFF, on	
oFF	PFC disabled	
on	PFC enabled.	



CAUTION!

If Power Factor Control is used, the EMC Directive will not be complied with. External measures will be necessary to meet the requirements of the EMC Directive.

Fan continuously on [342]

This parameter enables the internal fan to be switched on continuously. the default setting is for the fan only to run when the softstarter heatsink is too warm. The lifetime of the fan is increased by only running it when needed.

342 ^o		Setting
Fan continuously on		
o F F		
Default:	oFF	
Range:	oFF, on	
oFF	Fan is controlled by the heatsink temperature	
on	Fan is running continuously.	

8.8 Process protection

The MSF 2.0 softstarter is equipped with different functions for process protection:

[400]-[413] Shaft power monitor

[420] External alarm

[430]-[440] Mains protection

8.8.1 Shaft power monitor

The MSF 2.0 has a built-in shaft power monitor, which continuously supervises the motor shaft power. This means, the process can easily be protected both from overload and underload conditions. The shaft power monitor functionality includes both alarms and pre-alarms for overload (max power) and underload (min power). While the max. and min power alarms can be configured to affect operation (OFF, Warning, Coast, Stop, Alarm Brake), the respective pre-alarms only give an indication that an over- or underload situation may be close. The pre-alarm status is available on one of the programmable relays K1 to K3 if so configured (see description of the relays, menus [530] to [532] on page 86 for more information)

All shaft power monitor alarms and pre-alarms are configured using a delay time and an alarm margin. The alarm margin is chosen as a percentage of nominal motor load. A max power alarm will occur when the actual power exceeds the normal load plus the max power alarm margin and a min power alarm will occur when the actual load is lower than the normal load minus the min power margin. Normal load is the shaft power needed under normal operation conditions. The default normal load is considered to be 100% of the nominal motor power. Depending on the dimensioning of the motor with respect to the application, this value may need to be adapted. Normal load can easily be adapted by using the auto set function in menu [411]. When an auto set is performed the actual motor shaft power will be measured and stored to the Normal load.

A start delay can be configured to avoid faulty alarms due to initial over- or underload situations at start.

Fig. 52 illustrates the shaft power monitor functionality with an example of a load curve.

If the operation has been interrupted due to a max or min power alarm, a manual reset and a new start signal is needed to continue operation. The reset and the start signal can be given via control panel, remotely or via serial communication depending on the control source chosen in menu [200]. Regardless of the chosen control source, it is always possible to initiate a reset via control panel.

NOTE: A reset via control panel will never start the motor.

NOTE: The shaft power monitor alarms are disabled during deceleration.

NOTE: When using the shaft power monitor, check that the nominal motor power is set properly in menu [212].

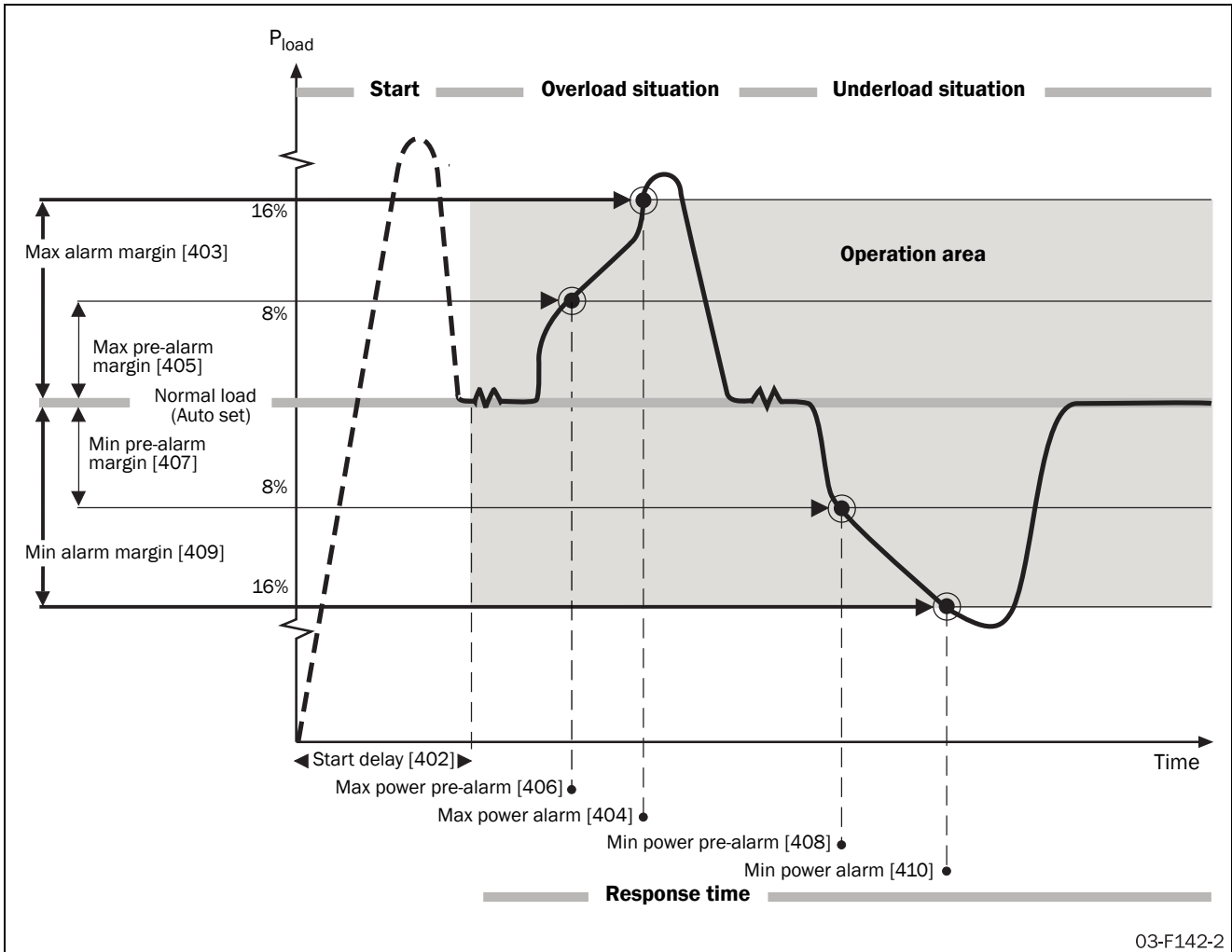

03-F142-2

Fig. 52 Shaft power monitor alarm functions

For max and min power alarms the following alarm actions are available:

Off

The protection method is deactivated.

Warning

The appropriate alarm message is shown in the display and relay K3 is activated (for default configuration of the relays). However, the motor is not stopped and operation continues. The alarm message will disappear and the relay will be reset when the fault disappears. The alarm may also be reset manually.

Coast

The appropriate alarm message is shown in the display and relay K3 is activated (for default configuration of the relays). The motor voltage is automatically switched off. The motor freewheels until it stops.

Stop

The appropriate alarm message is shown in the display and relay K3 is activated (for default configuration of the relays). The motor is stopped according to the stop settings in menus [320] to [325].

Alarm Brake

The appropriate alarm message is shown in the display and relay K3 is activated (for default configuration of the relays). The brake function is activated according to the braking method chosen in menu [323] and the motor is stopped according to the alarm brake settings in menus [326] to [327] (braking strength and braking time).

If the operation has been interrupted due to a max or min power alarm, a reset signal and a new start signal are needed to restart the motor. The reset and the start signal can be given via control panel, remotely or via serial communication depending on the control source chosen in

menu [200]. Regardless of the chosen control source, it is always possible to initiate a reset via control panel.

NOTE: A reset via control panel will never start the motor.

Max power alarm [400]

In this menu max power alarm is enabled and a proper alarm action is selected. The pre-alarm functionality for max power is automatically enabled together with the max power alarm.

400 ^o		Setting
<div style="border: 1px solid black; display: inline-block; padding: 2px;"> 0 F F </div>		Max power alarm (alarm code F6)
Default:	oFF	
Range:	oFF, 1, 2, 3, 4	
oFF	Max power alarm is disabled.	
1	Warning	
2	Coast	
3	Stop	
4	Alarm Brake	

Min power alarm [401]

In this menu min power alarm is enabled and a proper alarm action is selected. The pre-alarm functionality for min power is automatically enabled together with the min power alarm.

401 ^o		Setting
<div style="border: 1px solid black; display: inline-block; padding: 2px;"> 0 F F </div>		Min power alarm (alarm code F7)
Default:	oFF	
Range:	oFF, 1, 2, 3, 4	
oFF	Min power alarm is disabled.	
1	Warning	
2	Coast	
3	Stop	
4	Alarm Brake	

Start delay power alarms [402]

This menu is available if max or min power alarm is enabled in menu [400] or [401]. In this menu the start delay for the power alarms and pre-alarms is selected. A start delay is useful for avoiding faulty alarms due to initial over- or underload situations. The start delay begins when a start of the motor is initiated.

402 ^o		Setting
<div style="border: 1px solid black; display: inline-block; padding: 2px;"> 1 0 </div>		Start delay power alarms
Default:	10 s	
Range:	1-999 s	
1-999	Start delay for power alarms and pre-alarms.	

Max power alarm margin [403]

This menu is available if Max power alarm is enabled in menu [400]. In this menu the max power alarm margin is configured. The margin is selected as percentage of nominal motor power. A max power alarm will occur if the actual motor shaft power exceeds the normal load (menu [412]) plus the chosen max power alarm margin for a longer time period than the max power alarm response delay set in menu [404].

403 ^o		Setting
<div style="border: 1px solid black; display: inline-block; padding: 2px;"> 1 6 </div>		Max power alarm margin
Default:	16%	
Range:	0-100% of P _n	
0-100	Max power alarm margin	

Max power alarm response delay [404]

This menu is available if max power alarm is enabled in menu [400]. In this menu the response delay for the max power alarm is configured. A max power alarm will occur if the actual motor shaft power exceeds the normal load (menu [412]) plus the max power alarm margin set in menu [403] for a longer time period than the chosen max power alarm response delay.

404 ^o		Setting
<div style="border: 1px solid black; display: inline-block; padding: 2px;"> 0. 5 </div>		Max power alarm response delay
Default:	0.5 s	
Range:	0.1-90.0 s	
0.1-90.0	Response delay for max power alarm.	

Max power pre-alarm margin [405]

This menu is available if max power alarm is enabled in menu [400]. In this menu the max power pre-alarm margin is configured. The margin is selected in percent of nominal motor power. A max power pre-alarm will occur if the actual motor shaft power exceeds the normal load (menu [412]) plus the chosen max power pre-alarm margin for a longer time period than the max power pre-alarm response delay set in menu [406]. The max power pre-alarm status is available on one of the programmable relays K1-K3 if so configured (see description of the relays, menus [530] to [532] for more information).

405 ^o		Setting
<div style="border: 1px solid black; padding: 2px; display: inline-block;"> 8 </div>		Max power pre-alarm margin
Default:	8%	
Range:	0-100% of P _n	
0-100	Max power pre-alarm margin.	

Max power pre-alarm response delay [406]

This menu is available if max power alarm is enabled in menu [400]. In this menu the response delay for max power pre-alarm is configured. A max power pre-alarm will occur if the actual motor shaft power exceeds the normal load (menu [412]) plus the max power pre-alarm margin set in menu [405] for a longer time period than the chosen max power pre-alarm response delay.

406 ^o		Setting
<div style="border: 1px solid black; padding: 2px; display: inline-block;"> 0.5 </div>		Max power pre-alarm response delay
Default:	0.5 s	
Range:	0.1-90.0 s	
0.1-90.0	Response delay for Max power pre-alarm.	

Min power pre-alarm margin [407]

This menu is available if min power alarm is enabled in menu [401]. In this menu the min power pre-alarm margin is configured. The margin is selected as a percentage of nominal motor power. A min power pre-alarm will occur if the actual motor load is below the nominal load (menu [412]) minus the chosen min power pre-alarm margin for a longer time period than the min power pre-alarm response delay set in menu [408]. The min power pre-alarm status is available on one of the programmable relays K2-K3 if so configured (see description of the relays, menus [530] to [532] for more information).

407 ^o		Setting
<div style="border: 1px solid black; padding: 2px; display: inline-block;"> 8 </div>		Min power pre-alarm margin
Default:	8%	
Range:	0-100% of P _n	
0-100	Min power pre-alarm margin.	

Min power pre-alarm response delay [408]

This menu is available if min power alarm is enabled in menu [401]. In this menu the response delay for min power pre-alarm is configured. A min power pre-alarm will occur if the actual motor shaft power is below the normal load (menu [412]) minus the min power pre-alarm margin set in menu [407] for a longer time period than the chosen min power pre-alarm response delay.

408 ^o		Setting
<div style="border: 1px solid black; padding: 2px; display: inline-block;"> 0.5 </div>		Min power pre-alarm response delay
Default:	0.5 s	
Range:	0.1-90.0 s	
0.1-90.0	Response delay for Min power pre-alarm.	

Min power alarm margin [409]

This menu is available if min power alarm is enabled in menu [401]. In this menu the min power alarm margin is configured. The margin is selected as a percentage of nominal motor power. A min power alarm will occur if the actual motor shaft power is below the normal load (menu [412]) minus the chosen min power alarm margin for a longer time period than the min power alarm response delay set in menu [410].

409 ^o		Setting
<div style="border: 1px solid black; padding: 2px; display: inline-block;"> 1 6 </div>		Min power alarm margin
Default:	16%	
Range:	0-100% of P _n	
0-100	Min power alarm margin.	

Min power alarm response delay [410]

This menu is available if min power alarm is enabled in menu [401]. In this menu the response delay for min power alarm is configured. A min power alarm will occur if the actual motor shaft power is below the normal load (menu [412]) minus the min power alarm margin set in menu [409] for a longer time period than the chosen min power alarm response delay.

410 ^o		Setting
Min power alarm response delay		
0.5		
Default:	0.5 s	
Range:	0.1-90.0 s	
0.1-90.0	Response delay for Min power alarm.	

Auto set [411]

This menu is available if max or min power alarm is enabled in menu [400] or [401]. The Auto set command performs a measurement of the actual motor load and automatically sets the normal load in menu [412].

To perform an Auto set, select YES, and press “ENTER” during normal operation. If Auto set has been executed successfully, “Set” is shown in the display for two seconds. After that “no” is shown again. An Auto set can also be initiated via the analogue/digital input, see description of menu [500] for more information.

NOTE: Auto set is only allowed during full voltage running.

411 ^o		Multi Setting
Auto set		
no		
Default:	no	
Range:	no, YES	
no	No action	
YES	Auto set	

Normal load [412]

This menu is available if Max or Min power alarm is enabled in menu [400] or [401]. Normal load is the shaft power needed under normal operation conditions. By default, Normal load is considered to be 100% of the nominal motor power. Depending on the dimensioning of the motor with respect to the application, this value may need to be adapted. Normal load can easily be adapted by using the Auto set function in menu [411]. Normal load is set as a percentage of nominal motor power.

NOTE: When using the shaft power monitor, check that the nominal motor power is set properly in menu [212].

412 ^o		Setting
Normal load		
100		
Default:	100%	
Range:	0-200% of P _n	
0-200	Normal load	

Output shaft power [413]

This menu is available if max or min power alarm is enabled in menu [400] or [401]. The menu provides a read-out of the actual shaft power. It can be used as input information when the normal load is set manually.

413 ^o		Read-out
Output shaft power		
0		
Range:	0-200% of P _n	

8.8.2 External alarm [420]

The MSF 2.0 can generate an alarm according to the status of an external signal. For a detailed description of the external alarm functionality see section 8.9.5, page 92.

The following alternatives are available for external alarm:

Off

External alarm is deactivated.

Warning

Alarm message F17 is shown in the display and relay K3 is activated (for default configuration of the relays) if the external alarm input is opened. However, the motor is not stopped and operation continues. The alarm message will disappear and the relay will be reset when the external alarm input is activated again. The alarm may also be reset manually.

Coast

Alarm message F17 is shown in the display and relay K3 is activated (for default configuration of the relays) if the external alarm input is opened. The motor voltage is automatically switched off. The motor freewheels until it stops.

Stop

Alarm message F17 is shown in the display and relay K3 is activated (for default configuration of the relays) if the external alarm input is opened. The motor is stopped according to the stop settings in menus [320] to [325].

Alarm Brake

Alarm message F17 is shown in the display and relay K3 is activated (for default configuration of the relays) if the external alarm input is opened. The brake function is activated according to the braking method chosen in menu [323] and the motor is stopped according to the alarm brake settings in menus [326] to [327] (braking strength and braking time).

Spinbrake

The functionality for the spinbrake alternative is the same as described above for the alarm brake alternative. However, if spinbrake is chosen, braking can also be initiated from an inactive state by opening the external alarm input. This means the softstarter can catch a freewheeling motor and brake it down to standstill. The spinbrake alternative is only available for external alarm.

If the operation has been interrupted due to an external alarm, a reset signal and a new start signal are needed to restart the motor. The reset and the start signal can be given via control panel, remotely or via serial communication depending on the control source chosen in menu [200]. Regardless of the chosen control source, it is always possible to initiate a reset via control panel.

NOTE: A reset via control panel will never start the motor.

420 ^o		Setting
External alarm (alarm code F17)		
o F F		
Default:	oFF	
Range:	oFF, 1, 2, 3, 4, 5	
oFF	External alarm is disabled.	
1	Warning	
2	Coast	
3	Stop	
4	Alarm Brake	
5	Spinbrake	

8.8.3 Mains protection

The MSF 2.0 continuously monitors the mains voltage. This means the motor can easily be protected from over- and undervoltages as well as from voltage unbalance conditions. A phase reversal alarm is also available.

For mains protection the following alternatives are available:

Off

The protection method is deactivated.

Warning

The appropriate alarm message is shown in the display and relay K3 is activated (for default configuration of the relays).

However, the motor is not stopped and operation continues. The alarm message will disappear and the relay will be reset when the fault disappears. The alarm may also be reset manually.

Coast

The appropriate alarm message is shown in the display and relay K3 is activated (for default configuration of the relays). The motor voltage is automatically switched off. The motor freewheels until it stops.

Stop

The appropriate alarm message is shown in the display and relay K3 is activated (for default configuration of the relays). The motor is stopped according to the stop settings in menus [320] to [325].

Alarm Brake

The appropriate alarm message is shown in the display and relay K3 is activated (for default configuration of the relays). The brake function is activated according to the braking method chosen in menu [323] and the motor is stopped according to the alarm brake settings in menus [326] to [327] (braking strength and braking time).

An overvoltage, undervoltage or voltage unbalance alarm is automatically reset when a new start signal is given. If the operation has been interrupted due to a phase reversal alarm, a reset signal and a new start signal are needed to restart the motor. The reset and the start signal can be given via control panel, remotely or via serial communication depending on the control source chosen in menu [200]. Regardless of the chosen control source, it is always possible to initiate a reset via control panel.

NOTE: A reset via control panel will never start the motor.

Voltage unbalance alarm [430]

In this menu voltage unbalance alarm is enabled and a proper action is selected.

430 ^o		Setting
Voltage unbalance alarm (alarm code F8)		
o F F		
Default:	oFF	
Range:	oFF, 1, 2, 3, 4	
oFF	Voltage unbalance alarm is disabled.	
1	Warning	
2	Coast	
3	Stop	
4	Alarm Brake	

Unbalance voltage level [431]

This menu is available if voltage unbalance alarm is enabled in menu [430]. In this menu the maximum allowed voltage unbalance level is selected. If the difference between any two line voltages exceeds the chosen level for the response delay time set in menu [432], a voltage unbalance alarm will occur and the action selected in menu [430] will be executed.

431 ^o		Setting
Voltage unbalance level		
10		
Default:	10%	
Range:	2-25% of U_n	
2-25	Voltage unbalance level.	

Response delay voltage level unbalance alarm [432]

This menu is available if voltage unbalance alarm is enabled in menu [430]. In this menu the response delay for voltage unbalance alarm is selected. If the difference between any two line voltages exceeds the level set in menu [431] for the chosen response delay time, a voltage unbalance alarm will occur and the action selected in menu [430] will be executed.

432 ^o		Setting
Response delay voltage unbalance alarm		
1		
Default:	1 s	
Range:	1-90 s	
1-90	Response delay for voltage unbalance alarm.	

Overvoltage alarm [433]

In this menu overvoltage alarm is enabled and a proper action is selected.

433 ^o		Setting
Overvoltage alarm (alarm code F9)		
o F F		
Default:	oFF	
Range:	oFF, 1, 2, 3, 4	
oFF	Overvoltage alarm is disabled.	
1	Warning	
2	Coast	
3	Stop	
4	Alarm Brake	

Overvoltage level [434]

This menu is available if overvoltage alarm is enabled in menu [433]. In this menu the voltage level for an overvoltage alarm is selected. If any line voltage exceeds the chosen level for the response delay time set in menu [435], an overvoltage alarm will occur and the action selected in menu [433] will be executed.

434 ^o		Setting
Overvoltage level		
115		
Default:	115%	
Range:	100-150% of U_n	
100-150	Overvoltage level	

Response delay overvoltage alarm [435]

This menu is available if overvoltage alarm is enabled in menu [433]. In this menu the response delay for overvoltage alarm is selected. If any line voltage exceeds the level set in menu [434] for the chosen response delay time, an overvoltage alarm will occur and the action selected in menu [433] will be executed.

435 ^o		Setting
Response delay overvoltage alarm		
1		
Default:	1 s	
Range:	1-90 s	
1-90	Response delay for overvoltage alarm.	

Undervoltage alarm [436]

In this menu undervoltage alarm is enabled and a proper action is selected.

436 ^o		Setting
Undervoltage alarm (alarm code F10)		
o F F		
Default:	oFF	
Range:	oFF, 1, 2, 3, 4	
oFF	Undervoltage alarm is disabled.	
1	Warning	
2	Coast	
3	Stop	
4	Alarm Brake	

Undervoltage level [437]

This menu is available if undervoltage alarm is enabled in menu [436]. In this menu the voltage level for an undervoltage alarm is selected. If any line voltage is below the chosen level for the response delay time set in menu [438], an undervoltage alarm will occur and the action selected in menu [436] will be executed.

437 ^o		Setting
Undervoltage level		
85		
Default:	85%	
Range:	75-100% of U_n	
75-100	Undervoltage level	

Response delay undervoltage alarm [438]

This menu is available if undervoltage alarm is enabled in menu [436]. In this menu the response delay for undervoltage alarm is selected. If any line voltage is below the level set in menu [437] for the chosen response delay time, an undervoltage alarm will occur and the action selected in menu [436] will be executed.

438 ^o		Setting
Response delay undervoltage alarm		
1		
Default:	1 s	
Range:	1-90 s	
1-90	Response delay for undervoltage alarm	

Phase sequence [439]

In this menu the actual phase sequence is shown.

NOTE: The actual phase sequence can only be shown with a motor connected.

439 ^o		Read-out
Phase sequence		
L - -		
Range:	L123, L321	
L123	Phase sequence L1, L2, L3	
L321	Phase sequence L3, L2, L1	
L - -	Phase sequence can not be detected	

Phase reversal alarm [440]

In this menu phase reversal alarm is enabled and a proper action can be chosen. The softstarter will detect the phase sequence prior to each start attempt. If the actual phase sequence does not match the phase sequence stored during activation of phase reversal alarm, the action chosen in this menu will be executed. If alternative 2 (Coast) is chosen, no start will be performed if the wrong phase sequence is detected.

To activate phase reversal alarm, a motor has to be connected and the mains voltage has to be switched on. This means activation of phase reversal alarm can either be done in stopped state with the mains contactor switched on manually or during full voltage running.

440 ^o		Setting
Phase reversal alarm (alarm code F16)		
o F F		
Default:	oFF	
Range:	oFF, 1, 2	
oFF	Phase reversal alarm is disabled.	
1	Warning	
2	Coast	

NOTE: The actual phase sequence can be viewed in menu [439].

8.9 I/O settings

In this section the programmable inputs and outputs are described.

[500]-[513] Input signals

[520]-[534] Output signals

A connection example using most of the available in- and outputs is shown in Fig. 53.

This section includes also detailed descriptions of the following functions:

- Start/stop/reset command functionality
- Start right/left functionality
- External alarm functionality
- External control of parameter set

8.9.1 Input signals

The MSF 2.0 has one programmable analogue/digital input and four programmable digital inputs for remote control.

Analogue/digital input [500]

The analogue/digital input can either be configured for analogue or digital functionality. The following alternatives are available when using the input for digital signals:

Rotation sensor

An external rotation sensor can be used for the braking functions. If the analogue/digital input is configured for rotation sensor functionality in menu [500], braking will be deactivated if the number of edges chosen in menu [501] is detected on the input.

Slow speed

This alternative is used for slow speed controlled by an external signal (see the description of slow speed and JOG functions in section 8.7.4, page 65 for more information). If the number of edges set in menu [501] is detected on the input, slow speed at start or stop will be finished.

JOG Forward

With this alternative, slow speed in forward direction can be activated via the analogue/digital input. Slow speed will be active as long as the input signal is high. See the description of slow speed and JOG functions in section 8.7.4, page 65 for more information. Note that JOG forward has to be enabled in menu [334] to use this function.

JOG reverse

With this alternative, slow speed in reverse direction can be activated via the analogue/digital input. Slow speed will be active as long as the input signal is high. See the description of slow speed and JOG functions in section 8.7.4, page 65 for more information. Note that JOG reverse has to be enabled in menu [335] to use this function.

Auto set

When the analogue/digital input is configured for Auto set, a rising edge on the input will initiate an Auto set. Note that an Auto set only can be performed during full voltage running. See description of shaft power monitor functionality in section 8.8.1, page 70 for more information.

The following alternatives are available when using the input for analogue signals:

Analogue start/stop: 0-10 V/0-20 mA or 2-10 V/4-20 mA:

The analogue/digital input is used for the reference signal which controls analogue start stop. Two signal ranges (0-10 V/0-20 mA or 2-10 V/4-20 mA) can be chosen. Analogue start/stop is activated if alternative 6 or 7 is chosen in menu [500]. See the description of Analogue start/stop on page 80 for more information.

<div style="display: flex; justify-content: space-between; align-items: center;"> <div style="border: 1px solid black; padding: 2px;">500</div> <div style="border: 1px solid black; padding: 2px;">Setting</div> </div>	
<div style="display: flex; justify-content: center; align-items: center; gap: 10px;"> <div style="border: 1px solid black; padding: 2px;">o</div> <div style="border: 1px solid black; padding: 2px;">F</div> <div style="border: 1px solid black; padding: 2px;">F</div> </div> <p>Analogue/digital input</p>	
Default:	oFF
Range:	oFF, 1-7
oFF	Analogue/digital input disabled
1	Digital, Rotation sensor
2	Digital, Slow speed
3	Digital, JOG forward
4	Digital, JOG reverse
5	Digital, Auto set
6	Analogue start/stop: 0-10 V/0-20 mA
7	Analogue start/stop: 2-10 V/4-20 mA

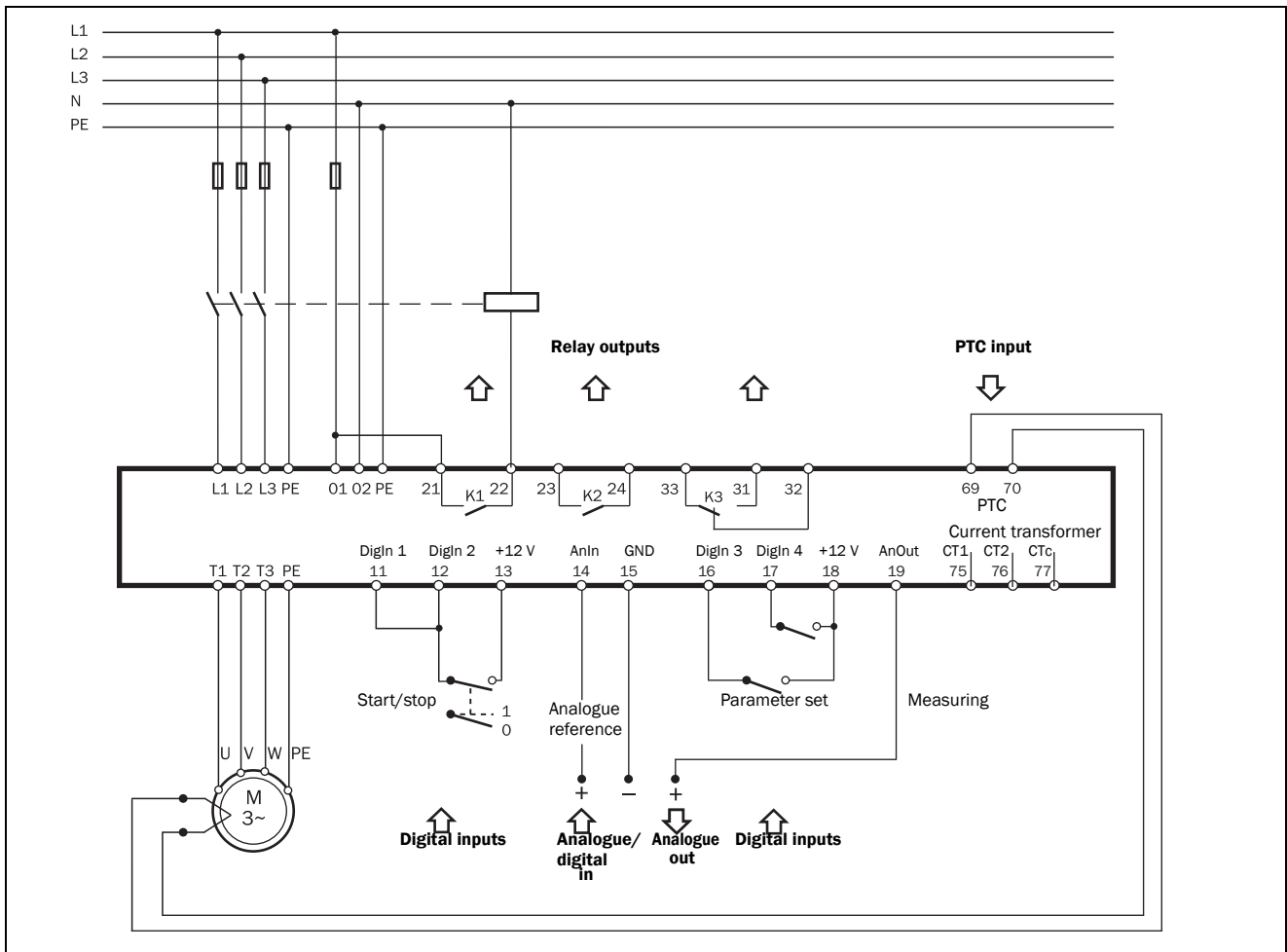

Fig. 53 Connection example when using the digital and analogue inputs and outputs

Digital input

The analogue/digital input is used as a digital input if one of alternatives 1-5 in menu [500] is selected. Jumper J1 has to be set for voltage control, which is the default setting.

The input signal is interpreted as 1 (high) when the input voltage exceeds 5 V. When the input voltage is below 5 V the input signal is interpreted as 0 (low). The input signal can be generated using the internal control supply voltage by connecting a switch between terminal 14 (analogue/digital input) and 18 (supply voltage to terminals 14, 16 and 17).

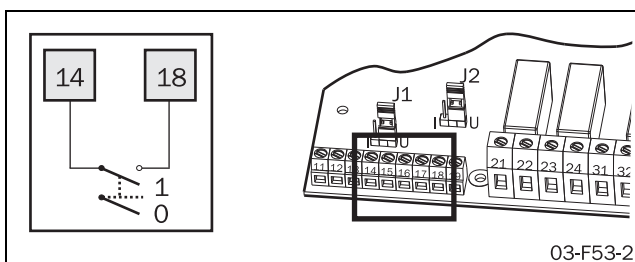

Fig. 54 Wiring for digital input signal.

Edges digital input [501]

This menu is available if the analogue/digital input is configured for digital input signals for rotation sensor (alternative 1) or for slow speed (alternative 2) in menu [500]. In this menu the number of edges is chosen to deactivate the braking function or the slow speed function respectively. .

NOTE: All edges, both positive and negative transitions, will be counted.

501	Setting
Edges digital input	
1	
Default:	1
Range:	1-100
1-100	Number of edges

Analogue input

The analogue/digital input is used as an analogue input if one of alternatives 6-7 in menu [500] is selected. In this case, the input can be configured for voltage or current signal using jumper J1 (see Fig. 55). By default jumper J1 is set to voltage signal. According to the chosen alternative in menu [500], the signal will be interpreted as 0-10 V/ 0-20 mA or 2-10 V/4-20 mA (see Fig. 56).

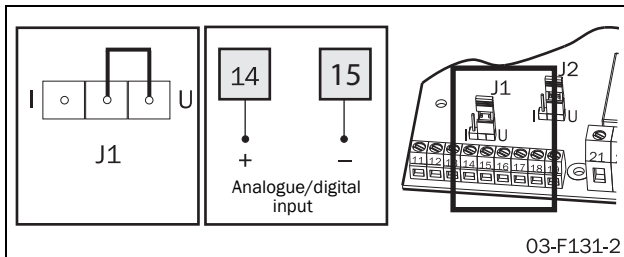

Fig. 55 Wiring for analogue/digital input and setting of J1 for analogue current or voltage control.

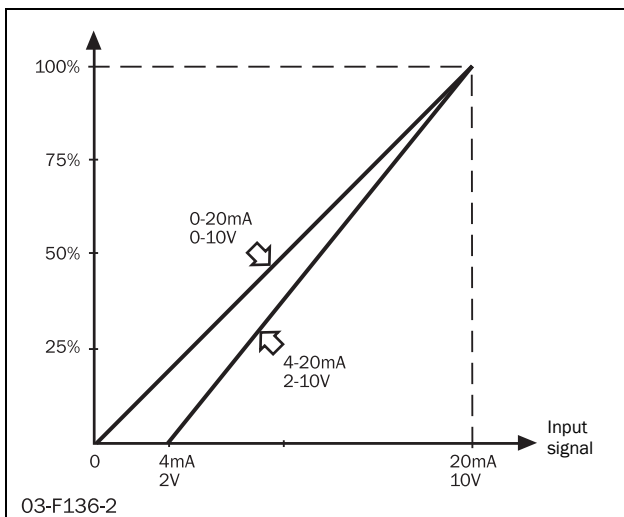

Fig. 56 Analogue input

Analogue start/stop

Starts and stops can be performed according to a process signal on the analogue/digital input. This means that e.g. the operation of a pump may be controlled according to a flow signal.

Analogue start/stop is available if remote control or serial communication control is chosen in menu [200] (alternatives 2 or 3).

NOTE: Analogue start/stop is not available if control panel is chosen as control source in menu [200] (alternative 1).

If a start signal is given via remote or serial communication (according to the setting in menu [200]), the softstarter will check the reference signal on the analogue/digital signal. A start will be performed if the level of the reference signal is below the analogue start/stop on-value chosen in menu

[502] for a longer time than the analogue start/stop delay time set in menu [504]. A stop will be performed if the reference signal exceeds the analogue start/stop off-value chosen in menu [503] for a longer time than the analogue start/stop delay time set in menu [504].

NOTE: If the selected analogue start/stop on-value is bigger than or equal to the off-value, a level above the on-value at the analogue input will cause a start. A value below the off-value will in this case cause a stop.

The start/stop LED on the front of the MSF will be flashing if the softstarter is in standby mode waiting for an analogue start.



WARNING!

A flashing start/stop LED is indicating standby mode - e.g. waiting for an analogue start. The motor may be started automatically at a moment's notice

Analogue start/stop on-value [502]

This menu is available if analogue start/stop is activated in menu [500] (alternative 6 or 7). If the reference signal on the analogue/digital input is below the chosen on-level for a longer time than the analogue start/stop delay time chosen in menu [504], a start will be performed..

NOTE: If the selected analogue start/stop on-value is bigger than or equal to the off-value, a level above the on-value at the analogue/digital input will cause a start.

NOTE: An analogue start will only be performed if the softstarter has been set to standby mode by a valid start signal via remote control or serial communication.

The analogue start/stop on-value is chosen as a percentage of the input signal range. This means, if the analogue/digital input is configured for 0-10 VDC/0-20 mA (alternative 6 in menu [500]), 25% corresponds to 2.5 V or 5 mA. If the analogue/digital input is configured for 2-10 VDC/4-20 mA (alternative 7 in menu [500]), 25% corresponds to 4 V or 8 mA.

502	Setting
25	Analogue start/stop on-value
Default:	25%
Range:	0-100% of input signal range
0-100	Analogue start/stop on-value.

Analogue start/stop off-value [503]

This menu is available if analogue start/stop is activated in menu [500] (alternatives 6 or 7). If the reference signal on the analogue/digital input exceeds the chosen off-level for a longer time than the analogue start/stop delay time chosen in menu [504], a stop will be performed.

NOTE: If the selected analogue start/stop off-value is less than or equal to the on-value, a level below the off-value at the analogue/digital input will cause a stop.

NOTE: A stop will also be performed if the softstarter receives a stop signal via remote control or serial communication.

The analogue start/stop off-value is chosen as a percentage of the input signal range. This means if the analogue/digital input is configured for 0-10 V / 0-20 mA (alternative 6 in menu [500]), 25% corresponds to 2.5 V or 5 mA. If the analogue/digital input is configured for 2-10 V / 4-20 mA (alternative 7 in menu [500]), 25% corresponds to 4 V or 8 mA.

503 Setting	
Analogue start/stop off-value	
75	
Default:	75%
Range:	0-100% of input signal range
0-100	Analogue start/stop off-value.

Analogue start/stop delay time [504]

This menu is available if analogue start/stop is activated in menu [500] (alternatives 6 or 7). In this menu the delay time for starts and stops caused by the analogue reference signal is set.

504 Setting	
Analogue start/stop delay time	
1 s	
Default:	1 s
Range:	1-999 s
1-999	Delay time for analogue start/stop

Digital inputs

The MSF 2.0 has four programmable digital inputs. The four inputs and their corresponding control supply terminals are shown overleaf in Fig. 57.

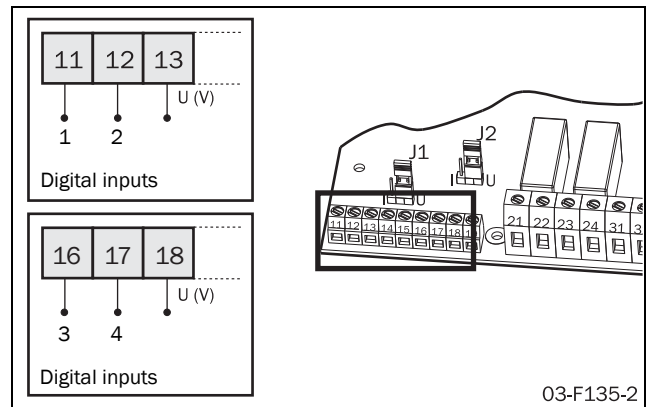

Fig. 57 Wiring for digital inputs 1-4.

The four digital inputs are electrically identical. The digital inputs can be used for remote control of start, stop and reset, for choice of parameter set and for external alarm.

Stop signal

If remote control is chosen in menu [200] (alternative 2), one digital input has to be configured for stop signal.

NOTE: No starts will be allowed if the input set for stop signal is open or if no input is configured for stop signal.

If the motor is running a stop will be performed according to the stop settings in menus [320] to [325] as soon as the input configured for stop signal is opened. If more than one input is configured for stop signal, opening one of these will lead to a stop. Accordingly no starts will be allowed if any of these inputs is open.

Start and reset signal

The digital inputs can be configured for several different start signals (start, start R or start L signal). Closing any input, which is configured for start, to its respective supply terminal will start the motor. Moreover, a rising edge on any input configured for start is interpreted as a reset signal.

NOTE: If more than one digital input is configured for any of the start signals (start, start R or start L), the following is valid:

If two inputs, which are configured for different start signals, are closed to their respective supply terminals at the same time no start will be allowed. If the motor is running, a stop will be performed.

If several digital inputs are configured for the same start signal, closing any of these inputs will lead to a start.

Naturally the softstarter has no way of controlling the motor's running direction internally. However, if two mains contactors – one for each phase sequence – are used, these can be controlled by the softstarter using the programmable relays. The settings for the programmable relays in menus [530] to [532] correspond to the different start signals, which can be chosen for the digital inputs. In this way different running directions for the motor can be chosen.

Example

1. If only one running direction is used, digital input 1 can be configured for start signal and digital input 2 for stop signal (default setting). In this case relay K1 may be configured for operation (default setting) and can control the mains relay. When digital inputs 1 and 2 are closed to their respective supply terminals, the mains contactor will be activated and the motor will start. When digital input 2 is opened the motor will stop. The mains contactor will be deactivated after the stop has been finished.
2. If two running directions are desired, digital input 1 can be configured for start R, digital input 2 for stop and digital input 3 for start L. Relay K1 controls the mains contactor for running in right direction and may be configured for Operation R. Relay K2 controls the mains contactor with the opposite phase sequence for running in left direction and may be configured for Operation L. In this case closing digital inputs 1 and 2 to their respective supply terminals (start right command) will lead to activation of the mains contactor for running in right direction and the motor will start in right direction. Opening digital input 2 will lead to a stop; the mains contactor for running right will be deactivated after the stop has been finished. Closing digital inputs 2 and 3 to their respective supply terminals (while digital input 1 is open) will lead to activation of the mains contactor for running in left direction and the motor will start in left direction.

For more information see the description of the start right/left functionality in section 8.9.4, page 88.

External alarm

The digital inputs can be configured as external alarm inputs. If an input configured for external alarm is opened, the action chosen in menu [420] for external alarm is performed. See description of the external alarm functionality in section 8.9.5, page 92 for more information.

NOTE: If more than one digital input is configured for external alarm, opening any of these will lead to an external alarm.

Parameter set

This configuration enables choice of parameter set by an external signal. See description of external control of parameter set in section 8.9.6, page 92 for more information.

Digital input 1 function [510]

In this menu the function for digital input 1 (terminal 11) is selected.

510 ^o		Setting
<div style="border: 1px solid black; display: inline-block; padding: 2px;"> 1 </div>		Digital input 1 function
Default:	1	
Range:	oFF, 1, 2, 3, 4, 5, 6, 7	
oFF	Digital input 1 is disabled	
1	Start signal	
2	Stop signal	
3	Parameter set, input 1	
4	Parameter set, input 2	
5	External alarm signal	
6	Start R signal	
7	Start L signal	

Digital input 2 function [511]

In this menu the function for digital input 2 (terminal 12) is selected.

511 ^o		Setting
<div style="border: 1px solid black; display: inline-block; padding: 2px;"> 2 </div>		Digital input 2 function
Default:	2	
Range:	Off, 1, 2, 3, 4, 5, 6, 7	
oFF	Digital input 2 is disabled.	
1	Start signal	
2	Stop signal	
3	Parameter set, input 1	
4	Parameter set, input 2	
5	External alarm signal	
6	Start R signal	
7	Start L signal	

Digital input 3 function [512]

In this menu the function for digital input 3 (terminal 16) is selected.

512 <input type="radio"/>		Setting
Digital input 3 function		
<input type="text" value=""/> <input type="text" value=""/> <input type="text" value=""/> <input type="text" value="3"/>		
Default:	3	
Range:	oFF, 1, 2, 3, 4, 5, 6, 7	
oFF	Digital input 3 is disabled.	
1	Start signal	
2	Stop signal	
3	Parameter set, input 1	
4	Parameter set, input 2	
5	External alarm signal	
6	Start R signal	
7	Start L signal	

Digital input 4 function [513]

In this menu the function for digital input 4 (terminal 17) is selected.

513 <input type="radio"/>		Setting
Digital input 4 function		
<input type="text" value=""/> <input type="text" value=""/> <input type="text" value=""/> <input type="text" value="4"/>		
Default:	4	
Range:	oFF, 1, 2, 3, 4, 5, 6, 7	
oFF	Digital input 4 is disabled.	
1	Start signal	
2	Stop signal	
3	Parameter set, input 1	
4	Parameter set, input 2	
5	External alarm signal	
6	Start R signal	
7	Start L signal	

8.9.2 Output signals

The MSF 2.0 has one programmable analogue output and three programmable relays.

Analogue output

The analogue output can present current, voltage, shaft power and torque for connection to a recording instrument, PLC etc. The external device is connected to terminals 19 (+) and 15 (-) according to Fig. 58 below. The analogue output can be configured for voltage or current signal. The

selection is made by jumper J2 on the control board. The default setting for J2 is voltage signal according to Fig. 58.

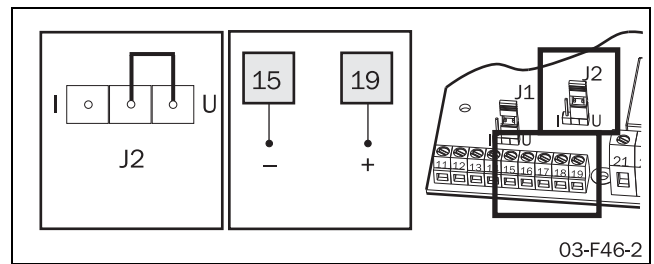

Fig. 58 Wiring for analogue output and setting of J2 for analogue current or voltage signal.

Analogue output [520]

In this menu the analogue output can be set to provide either one of the signal ranges shown in Fig. 59.

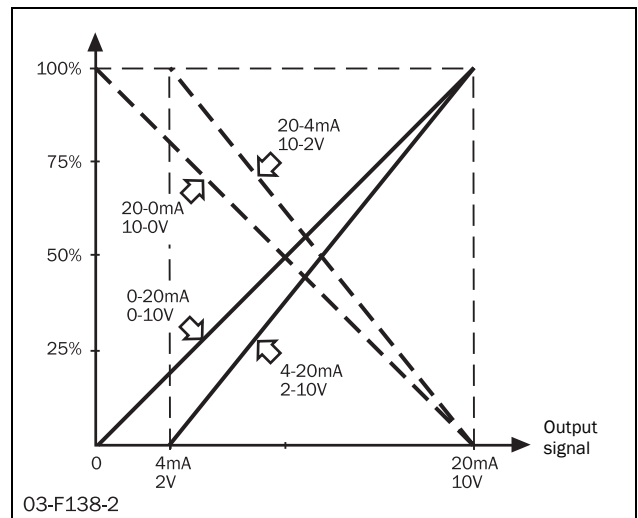

Fig. 59 Analogue output

520 <input type="radio"/>		Setting
Analogue output		
<input type="text" value=""/> <input type="text" value=""/> <input type="text" value=""/> <input type="text" value="OFF"/>		
Default:	oFF	
Range:	oFF, 1, 2, 3, 4	
oFF	Analogue output is disabled.	
1	Analogue signal 0-10 V/0-20 mA	
2	Analogue signal 2-10 V/4-20 mA	
3	Analogue signal 10-0 V/20-0 mA	
4	Analogue signal 10-2 V/20-4 mA	

Analogue output function [521]

This menu is available if the analogue output is enabled in menu [520] (alternatives 1-4). In this menu the desired output function is chosen.

521 ^o _o		Setting				
Analogue output function						
<table border="1"> <tr> <td style="width: 20px; height: 20px;"></td> <td style="width: 20px; height: 20px;"></td> <td style="width: 20px; height: 20px;"></td> <td style="width: 20px; height: 20px; text-align: center;">1</td> </tr> </table>						1
			1			
Default:	1					
Range:	1, 2, 3, 4					
1	RMS current					
2	Line voltage					
3	Shaft power					
4	Torque					

The scaling of the analogue output is reset to the default values (0-100%) if a new output value is chosen in menu [521].

Analogue output scaling

By default the scaling of the analogue output corresponds to Fig. 60. In this case the signal range of the analogue output chosen in menu [520] corresponds to 0 to 100% of the nominal motor current I_n , the nominal motor voltage U_n , the nominal motor power P_n or the nominal motor torque T_n respectively.

Example

If 0-10 V / 0-20 mA is chosen in menu [520] (alternative 1) and RMS current is chosen as output value in menu [521] (alternative 1), a current of 100% of the nominal motor current gives 10 V or 20 mA at the analogue output. A current of 25% of the nominal motor current gives 2.5 V or 5 mA at the analogue output.

The scaling of the analogue output may be adapted for higher resolution or if values above the nominal values are to be monitored. The scaling is done by choosing a minimum scaling value in menu [522] and a maximum value in menu [523]. An example for a different scaling is shown in Fig. 60.

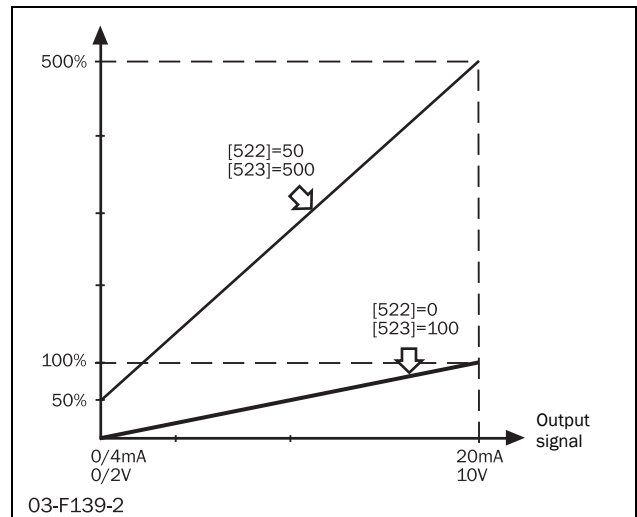

Fig. 60 Scaling of analogue output

With the scaling for wide range (parameter [522]=50 and parameter [523]=500) according to the example in Fig. 60 the following will apply.

If 0-10 V/0-20 mA is chosen in menu [520] (alternative 1) and RMS current is chosen as output value in menu [521] (alternative 1), a current of 100% of the nominal motor current gives approximately 1.1 V or 2.2 mA at the analogue output.

Scaling analogue output, min [522]

This menu is available if the analogue output is enabled in menu [520]. In this menu the minimum value to be shown at the analogue output is chosen. The value is chosen in percent of I_n , U_n , P_n or T_n according to the output value chosen in menu [521].

522 ^o _o		Setting				
Scaling analogue output, min						
<table border="1"> <tr> <td style="width: 20px; height: 20px;"></td> <td style="width: 20px; height: 20px;"></td> <td style="width: 20px; height: 20px;"></td> <td style="width: 20px; height: 20px; text-align: center;">0</td> </tr> </table>						0
			0			
Default:	0%					
Range:	0-500%					
0-500	Minimum output value					

NOTE: The minimum value for scaling the analogue output is reset to the default value 0% if a new output value is chosen in menu [521].

Scaling analogue output, max [523]

This menu is available if the analogue output is enabled in menu [520]. In this menu the maximum value to be shown at the analogue output is chosen. The value is chosen as a percentage of I_n , U_n , P_n or T_n according to the output value chosen in menu [521].

<div style="display: flex; justify-content: space-between; align-items: center;"> <div style="border: 1px solid black; padding: 2px;">523^o</div> <div style="border: 1px solid black; padding: 2px;">Setting</div> </div>	
Scaling analogue output, max	
<div style="border: 1px solid black; padding: 5px; display: inline-block;"> 1 0 0 </div>	
Default:	100%
Range:	0-500%
0-500	Maximum output value.

NOTE: The maximum value for scaling the analogue output is reset to the default value 100% if a new output value is chosen in menu [521].

Programmable relay outputs

The softstarter has three built-in relays, K1, K2 and K3. All three relays are programmable.

For relay K1 (terminals 21 and 22) and K2 (terminals 23 and 24) the contact function can be configured in menus [533] and [534] respectively to be normally open (NO) or normally closed (NC). Relay K3 is a change-over relay with three terminals (31-33), the NO functionality is available between terminals 31 and 32, NC functionality between terminals 32 and 33.

The relays can be used to control mains contactors or a bypass contactor or to indicate alarm conditions. As illustrated in Fig. 61 overleaf, the Operation setting (alternative 1) should be chosen to activate the mains contactor both during start, full voltage operation and stop. If a by-pass contactor is used, this can be controlled by a relay with the setting Full voltage (2). The settings Run (5) and Reverse current brake (4) are used when reverse current brake is chosen as stop method. In this case one relay has to be configured for Run and will control the mains contactor during the start and during full voltage operation. Another relay has to be configured for Reverse current brake and will control the contactor with reversed phase sequence during braking. For security reasons the relay configured for Reverse current brake will not be activated until after a time delay of 500 ms after deactivation of the relay configured for Run.

The settings Run R, Run L, Operation R and Operation L are used for the start right/left functionality. Consult section 8.9.4, page 88 for more information.

Different alarms can also be indicated on the relay outputs. With the setting Power pre-alarms (alternative 3), both a Max power pre-alarm or a Min power pre-alarm occurring will activate the relay. When Power alarms (10) is chosen as a setting, both a Max power alarm or a Min power alarm will activate the relay. If so desired, the relays can instead be

configured to react only to one specific power alarm or pre-alarm (11 - 14).

With setting All alarms (15) the relay will be activated for any alarm. As the power pre-alarms are not considered to be real alarms, the relay will not react to those. With alternative 16 chosen, the power alarms are excluded, too. When External alarm (17) is chosen, only an External alarm will activate the relay. With setting 18, Auto reset expired, the relay will be activated when an additional fault occurs after the maximum allowed number of auto reset attempts have been executed. This may indicate that external help is needed to rectify a re-occurring fault (see description of Auto reset in section 8.5, page 52 for detailed information). With alternative 19 the relay will indicate all alarms which need a manual reset. This includes all alarms which are not solved with an automatic Auto reset, e.g. all alarms for which Auto reset is not enabled and each alarm occurring after the maximum allowed number of auto reset attempts has been executed.

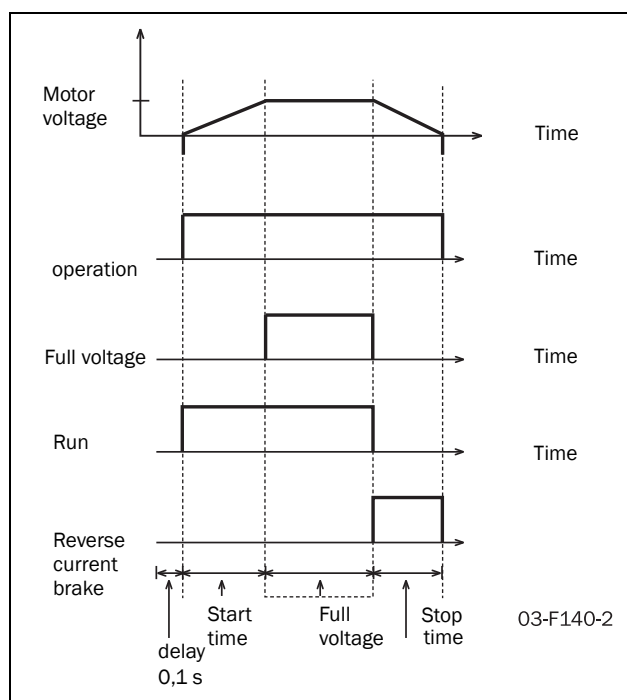

Fig. 61 The relay functions for operation, run and full voltage.

Relay K1 [530]

In this menu the function for relay K1 (terminals 21 and 22) is chosen.

530 ^o		Setting				
Relay K1						
<table border="1" style="display: inline-table;"> <tr> <td style="width: 20px; height: 20px;"></td> <td style="width: 20px; height: 20px;"></td> <td style="width: 20px; height: 20px;"></td> <td style="width: 20px; height: 20px; text-align: center;">1</td> </tr> </table>						1
			1			
Default:	1					
Range:	oFF, 1 - 19					
oFF	Relay inactive					
1	Operation					
2	Full voltage					
3	Power pre-alarms					
4	Reverse current brake					
5	Run					
6	Run R					
7	Run L					
8	Operation R					
9	Operation L					
10	Power alarms					
11	Max power alarm					
12	Max power pre-alarm					
13	Min power alarm					
14	Min power pre-alarm					
15	All alarms (except power pre-alarms)					
16	All alarms (except power alarms and pre-alarms)					
17	External alarm					
18	Auto reset expired					
19	All alarms which need manual reset					

NOTE: If relay K1 is chosen to be inactive (oFF), the relay state is determined by the contact function in menu [533].



WARNING!

When reverse current brake is activated by changing the settings in menu [320] (stop method), [323] (braking method) or [326] (alarm brake strength), relay K1 is automatically set for Run (5). If a different setting is desired for the specific application, the relay setting has to be changed afterwards.

Relay K2 [531]

In this menu the function for relay K2 (terminals 23 and 24) is chosen.

531 ^o		Setting				
Relay K2						
<table border="1" style="display: inline-table;"> <tr> <td style="width: 20px; height: 20px;"></td> <td style="width: 20px; height: 20px;"></td> <td style="width: 20px; height: 20px;"></td> <td style="width: 20px; height: 20px; text-align: center;">2</td> </tr> </table>						2
			2			
Default:	2					
Range:	oFF, 1-19					
oFF	Relay inactive					
1-19	See menu "Relay K1 [530]" for setting alternatives.					

NOTE: If relay K2 is chosen to be inactive (oFF), the relay state is determined by the contact function in menu [534].



WARNING!

When reverse current brake is activated by changing the settings in menu [320] (stop method), [323] (braking method) or [326] (alarm brake strength), relay K2 is automatically set for Reverse current brake (4). If a different setting is desired for the specific application, the relay setting has to be changed afterwards.

Relay K3 [532]

In this menu the function for relay K3 (terminals 31-33) is chosen.

532 ^o		Setting				
Relay K3						
<table border="1" style="display: inline-table;"> <tr> <td style="width: 20px; height: 20px;"></td> <td style="width: 20px; height: 20px;"></td> <td style="width: 20px; height: 20px; text-align: center;">1</td> <td style="width: 20px; height: 20px; text-align: center;">5</td> </tr> </table>					1	5
		1	5			
Default:	15					
Range:	oFF, 1-19					
oFF	Relay inactive					
1-19	See menu "Relay K1 [530]" for setting alternatives.					

K1 contact function [533]

In this menu the contact function for relay K1 can be chosen. The available alternatives are Normally open (1=Closing on relay activation) and Normally closed (2=Opening on relay activation).

533 <input type="radio"/>		Setting				
K1 contact function						
<table border="1" style="width: 100%;"> <tr> <td style="width: 25%;"></td> <td style="width: 25%;"></td> <td style="width: 25%;"></td> <td style="width: 25%; text-align: center;">1</td> </tr> </table>						1
			1			
Default:	1					
Range:	1, 2					
1	Normally open (N.O.)					
2	Normally closed (N.C.)					

K2 contact function [534]

In this menu the contact function for relay K2 can be chosen. The available alternatives are Normally open (1=Closing on relay activation) and Normally closed (2=Opening on relay activation).

534 <input type="radio"/>		Setting				
K2 contact function						
<table border="1" style="width: 100%;"> <tr> <td style="width: 25%;"></td> <td style="width: 25%;"></td> <td style="width: 25%;"></td> <td style="width: 25%; text-align: center;">1</td> </tr> </table>						1
			1			
Default:	1					
Range:	1, 2					
1	Normally open (N.O.)					
2	Normally closed (N.C.)					

8.9.3 Start/stop/reset command functionality

Starting/stopping of the motor and alarm reset is done either from the control panel, through the remote control inputs or through the serial communication interface depending on the control source chosen in menu [200].

Control panel

To start and stop from the control panel, the “START/STOP” key is used.

To reset from the control panel, the “ENTER ↵ /RESET” key is used.

Regardless of the chosen control source, it is always possible to initiate a reset via the control panel.

NOTE: A reset via the control panel will never start the motor.

Serial communication

For description of the start, stop and reset commands via serial communication see the operation instruction supplied with this option.

Remote control

When remote control is chosen in menu [200], the digital inputs are used to start and stop the motor and to reset upcoming alarms. In the following sections different possibilities for connecting the digital inputs are described. For the following explanations the following settings are assumed:

Menu	Description	Setting
510	Digital input 1 (terminal 11)	Start signal (1)
511	Digital input 2 (terminal 12)	Stop signal (2)

2-wire start/stop with automatic reset at start

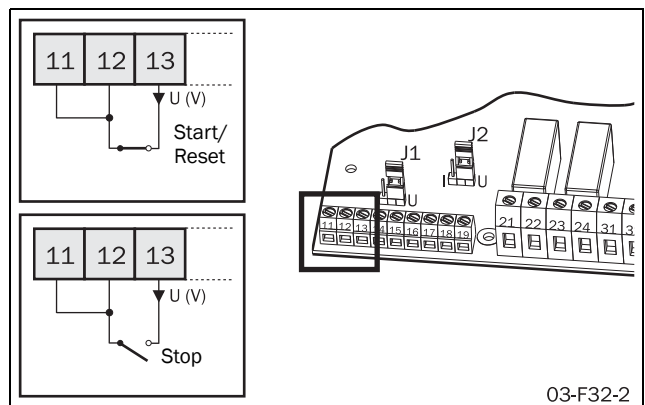

Fig. 62 2-wire connection of terminals for start/stop/automatic reset at start

An external switch is connected between terminals 12 and 13 and a jumper is connected between terminals 11 and 12.

Start

Closing terminal 12 to terminal 13 will give a start command. If terminal 12 is closed to terminal 13 at power up, a start command is given immediately (automatic start at power up).

Stop

Opening the connection between terminals 12 and 13 will give a stop command.

Reset

When a start command is given there will automatically be a reset.

2-wire start/stop with separate reset

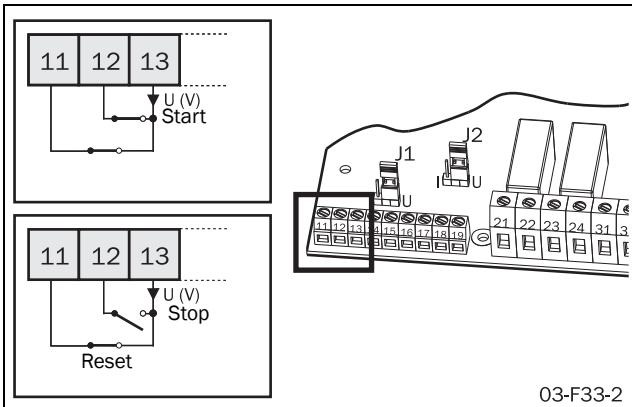

Fig. 63 2-wire connection of terminals for start/stop/separate reset

An external switch is connected between terminals 11 and 13 and a second switch is connected between terminals 12 and 13.

Start

Closing terminals 11 and 12 to terminal 13 will give a start command. If terminals 11 and 12 are closed to terminal 13 at power up, a start command is given immediately (automatic start at power up).

Stop

Opening the connection between terminals 12 and 13 will give a stop command.

Reset

When the connection between terminals 11 and 13 is opened and closed again a reset is given. A reset can be given both when the motor is running and when it is stopped.

3-wire start/stop with automatic reset at start

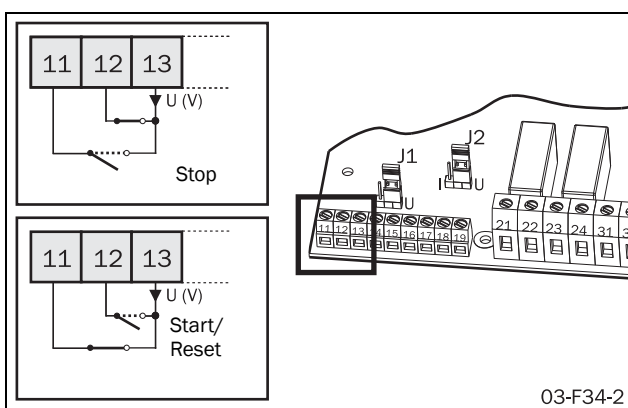

Fig. 64 3-wire start/stop with automatic reset at start

An external switch is connected between terminals 11 and 13 and a second switch is connected between terminals 12 and 13.

The connection between terminals 11 and 13 is normally open and the connection between terminals 12 and 13 is normally closed.

Start

Closing terminal 11 momentarily to terminal 13, will give a start command. There will not be an automatic start at power up.

Stop

When the connection between terminals 12 and 13 is momentarily opened, a stop command is given.

Reset

When a start command is given there will automatically be a reset.

8.9.4 Start right/left functionality

The digital inputs can be configured to enable starting a motor in two different directions in combination with the programmable relays K1 and K2. A connection example is shown in Fig. 65. For the following description of the start right/left functionality, the following settings for the digital inputs are assumed.

Menu	Description	Setting
510	Digital input 1 (terminal 11)	Start R signal (6)
511	Digital input 2 (terminal 12)	Stop signal (2)
512	Digital input 3 (terminal 16)	Start L signal (7)



CAUTION!

Very high currents can arise when the motor is reversed from running at full speed in one direction to running at full speed in the opposite direction.



WARNING!

If configured according to the description above, relays K1 and K2 will never be activated at the same time. There is a time delay of 500 ms for the change-over between the relays. However, if the relays are not configured properly, they may be activated at the same time.

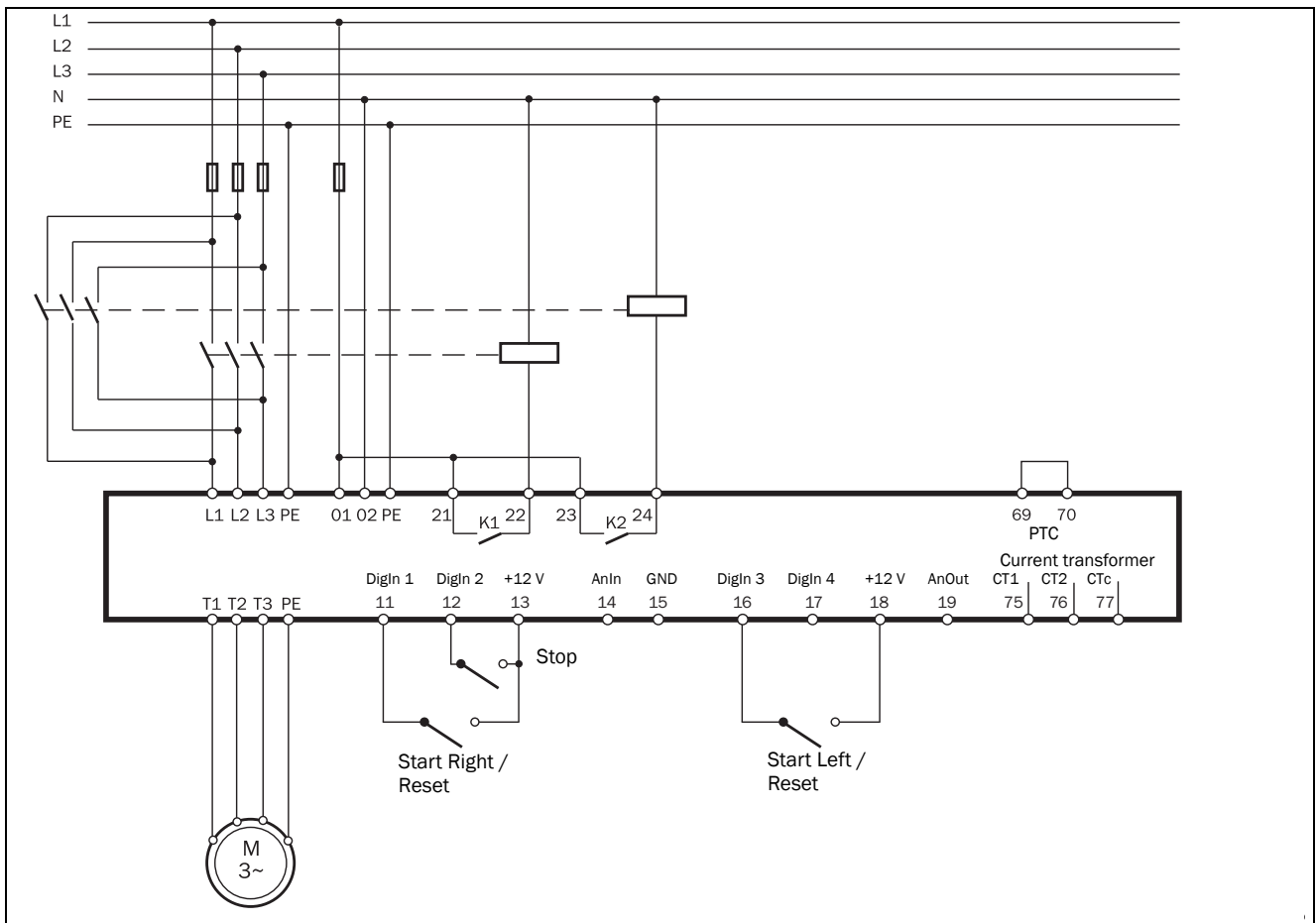

Fig. 65 Connection for start right/left

The configuration of the relays depends on the application's requirements. For applications which **do not** use the reverse current brake functionality, the following settings may be used.

Menu	Description	Setting
530	Relay K1 (terminals 21 and 22)	Operation R (8)
531	Relay K2 (terminals 23 and 24)	Operation L (9)

With these settings the functionality is as follows:

If terminals 11 and 12 are closed to terminal 13 while the connection between terminals 16 and 18 is open, the mains contactor for running in right direction will be activated by relay K1 and the motor will start in right direction. The connection between terminals 11 and 13 can be opened during running right without any effect. If the connection between terminals 12 and 13 is opened, a stop according to the stop settings in menus [320] to [325] will be performed. When the stop is finished, the mains contactor for running right will be deactivated by relay K1.

If terminal 12 is closed to terminal 13 and terminal 16 is closed to terminal 18 while the connection between terminals 11 and 13 is open, the mains contactor for

running in left direction will be activated by relay K2 and the motor will start in left direction. The connection between terminals 16 and 18 can be opened during running left without any effect. If the connection between terminals 12 and 13 is opened, a stop according to the stop settings in menus [320] to [325] will be performed. When the stop is finished, the mains contactor for running left will be deactivated by relay K2.

If both start terminals (11 and 16) are closed to their respective supply voltage at the same time, a stop is performed according to the stop settings in menus [320] to [325]. In this case no start will be allowed.

A motor can be reversed from right to left direction as follows: Open the connection between terminals 11 and 13 while the motor is running in right direction. then close terminal 16 to terminal 18. As a result the voltage to the motor is switched off and the mains contactor for running right is deactivated by relay K1. After a time delay of 500 ms the mains contactor for running left will be activated by relay K2 and a start in left direction will be performed. The motor can be reversed from running left to running right in the same way by opening the connection between terminals 16 and 18 while running left and then closing terminal 11 to terminal 13

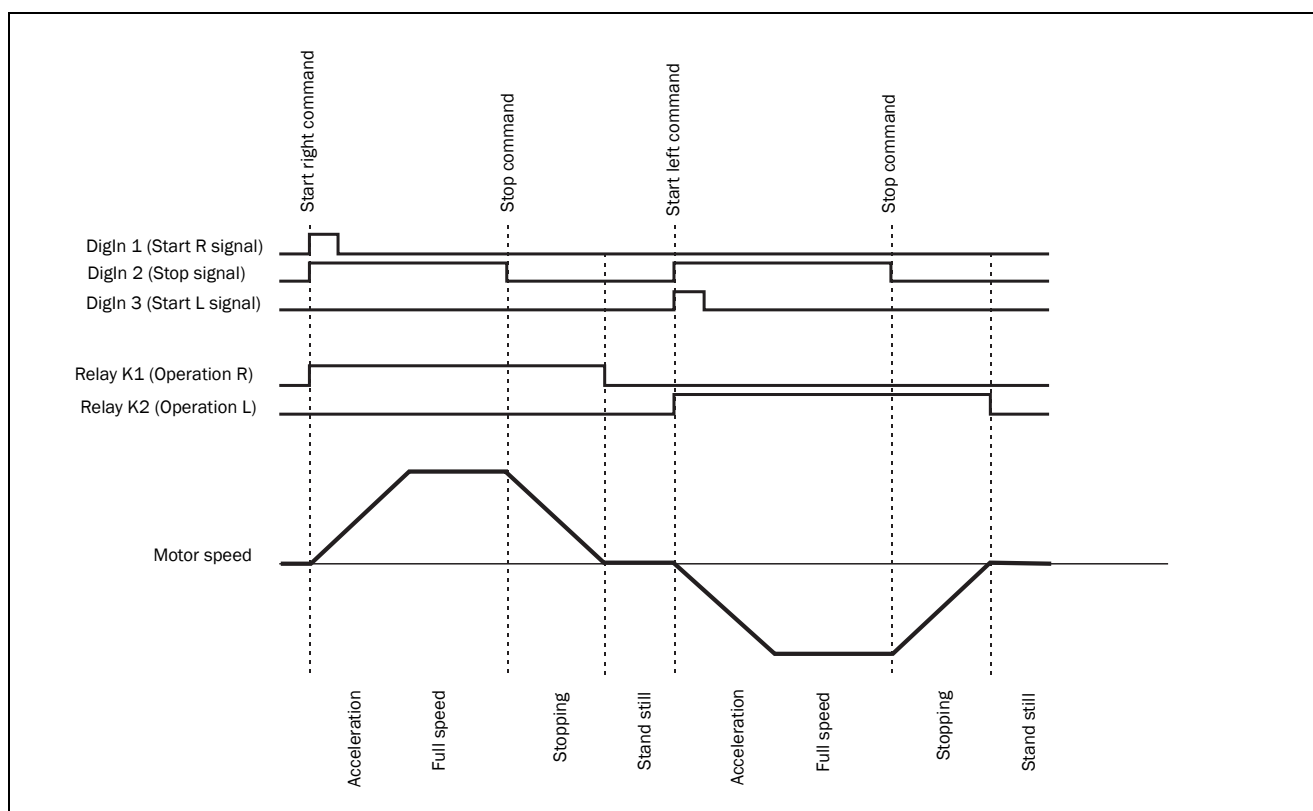

Fig. 66 Start right/left

For applications which use the reverse current brake functionality, the following settings for the relays may be used.

Menu	Description	Setting
530	Relay K1 (terminals 21 and 22)	Run R (6)
531	Relay K2 (terminals 23 and 24)	Run L (7)

With these settings the functionality is as follows:

If terminals 11 and 12 are closed to terminal 13 while the connection between terminals 16 and 18 is open, the mains contactor for running in right direction will be activated by relay K1 and the motor will start in right direction. The connection between terminals 11 and 13 can be opened during running right without any effect. If the connection between terminals 12 and 13 is opened the voltage to the motor is switched off and the mains contactor for running right is deactivated by relay K1. After a time delay of 500 ms the mains contactor for running left will be activated by relay K2 and the reverse current brake will brake the motor to standstill. When the stop is finished, the mains contactor for running left will be deactivated by relay K2.

If terminal 12 is closed to terminal 13 and terminal 16 is closed to terminal 18 while the connection between terminals 11 and 13 is open, the mains contactor for running in left direction will be activated by relay K2 and the motor will start in left direction. The connection

between terminals 16 and 18 can be opened during running left without any effect. If the connection between terminals 12 and 13 is opened the voltage to the motor is switched off and the mains contactor for running left is deactivated by relay K2. After a time delay of 500 ms the mains contactor for running right will be activated by relay K1 and the reverse current brake will brake the motor to standstill. When the stop is finished, the mains contactor for running right will be deactivated by relay K1.

If both start terminals (11 and 16) are closed to their respective supply voltage at the same time, a stop is performed in the same way as described above. In this case no start will be allowed.

A motor can be reversed in the same way as described above for applications which do not use the reverse current brake functionality.

NOTE: When reverse current brake is activated by changing the settings in menu [320] (stop method), [323] (braking method) or [326] (alarm brake strength), relay K1 is automatically set for Run (5) and relay K2 is automatically set for Reverse current brake (4). To use the start right/left functionality in combination with reverse brake, the relay settings have to be adapted as described above after reverse current brake has been configured.

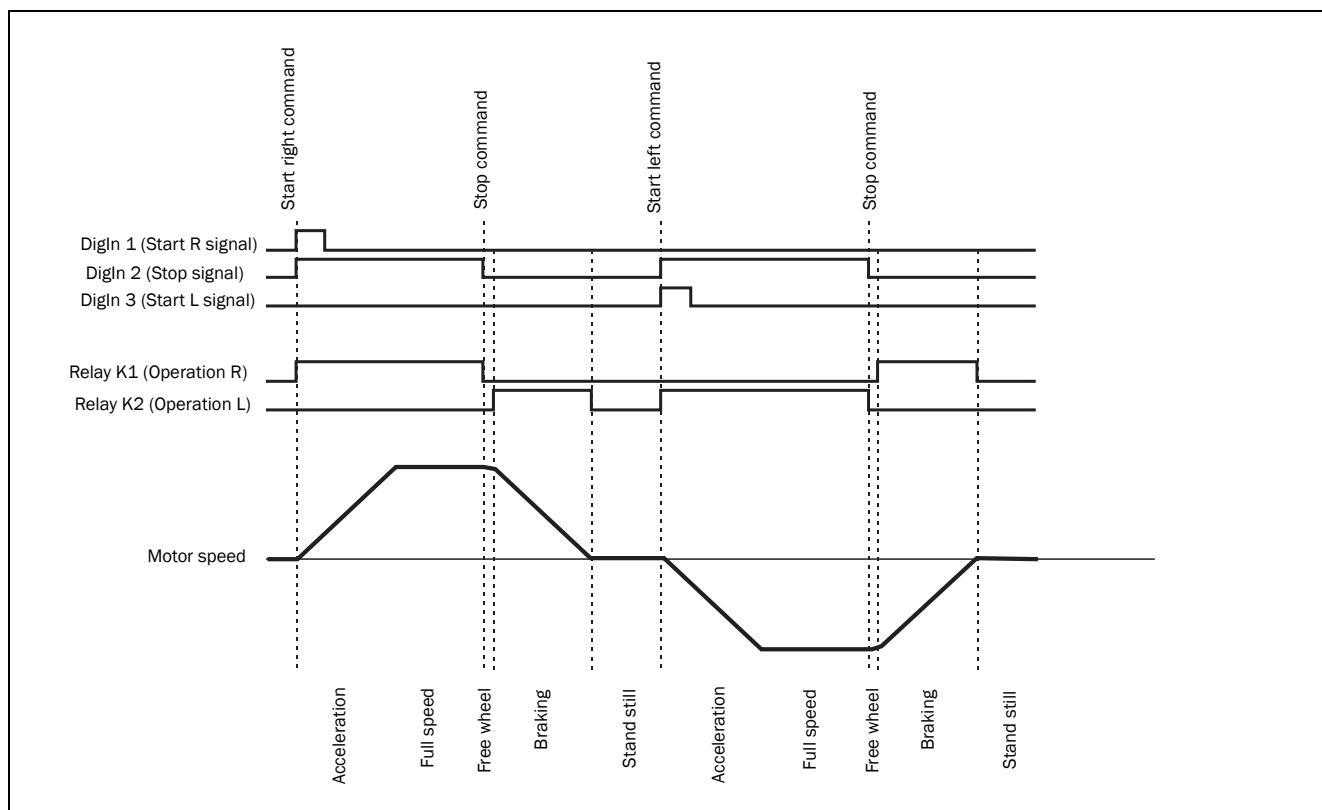

Fig. 67 Start right/left with reverse current brake

8.9.5 External alarm functionality

The external alarm functionality is used to generate an alarm depending on the state of an external alarm signal. Each of the digital inputs can be configured for external alarm signal. Fig. 68 shows a connection example with digital input 3 (terminal 16) configured for external alarm signal.

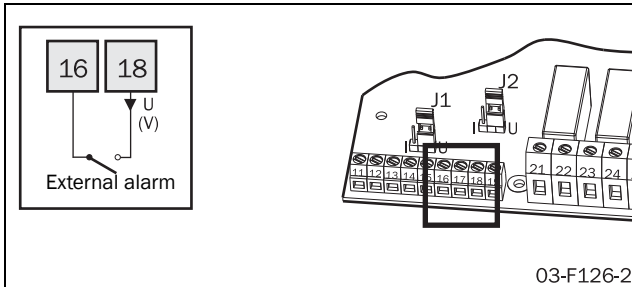

Fig. 68 Connection of terminals for external alarm

If any digital input is configured for external alarm signal, opening this input will cause an external alarm to occur if external alarm is enabled in menu [420].

NOTE: If more than one digital input is configured for external alarm signal, opening any of these inputs will generate an external alarm if external alarm is enabled in menu [420].

The following alarm actions are available for external alarm:

Off

External alarm is disabled.

Warning

An F17 alarm message is shown in the display and relay K3 is activated (for default configuration of the relays) if the connection between the external alarm input and the signal supply terminal is opened. However, the motor is not stopped and operation continues. The alarm message will disappear and the relay will be reset when the external alarm input is closed to its signal supply again. The alarm may also be reset manually.

Coast

An F17 alarm message is shown in the display and relay K3 is activated (for default configuration of the relays) if the connection between the external alarm input and the signal supply terminal is opened. The motor voltage is automatically switched off. The motor freewheels until it stops.

Stop

The appropriate alarm message is shown in the display and relay K3 is activated (for default configuration of the relays) if the connection between the external alarm input and the signal supply terminal is opened. The motor is stopped according to the stop settings in menus [320] to [325].

Alarm Brake

The appropriate alarm message is shown in the display and relay K3 is activated (for default configuration of the relays)

if the connection between the external alarm input and the signal supply terminal is opened. The brake function is activated according to the braking method chosen in menu [323] and the motor is stopped according to the alarm brake settings in menu [326] - [327] (Braking strength and braking time).

Spinbrake

The functionality for the spinbrake alternative is the same as described above for the alarm brake alternative. However, if spinbrake is chosen, braking can also be initiated from an inactive state by opening the connection between the external alarm input and the signal supply terminal. This means the softstarter can catch a freewheeling motor and brake it down to standstill. The Spinbrake alternative is only available for external alarm.

External alarm can be used together with any setting for the control source chosen in menu [200].

If the operation has been interrupted due to an external alarm, a reset signal and a new start signal are needed to restart the motor. The reset and the start signal can be given via control panel, remote or via serial communication depending on the control source chosen in menu [200]. Regardless of the chosen control source, it is always possible to initiate a reset via control panel.

NOTE: A reset via control panel will never start the motor.

8.9.6 External control of parameter set

The parameter set can be chosen via the digital inputs if external control of parameter set is chosen in menu [240] (alternative 0). For this purpose any of the digital inputs can be configured for parameter set input 1 (PS1, alternative 3 in menus [510] to [513]) or parameter set input 2 (PS2, alternative 4 in menus [510] to [513]). Fig. 69 shows a connection example for external control of parameter set, in this example digital inputs 3 and 4 are configured for PS1 and PS2.

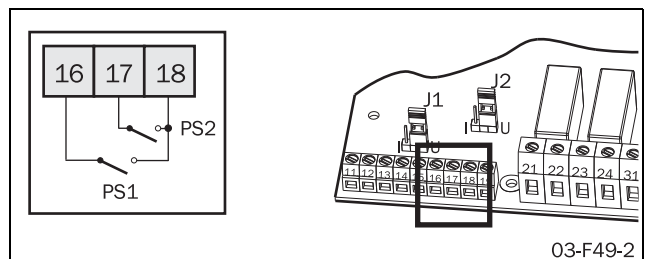

Fig. 69 Connection of external control inputs.

Table 16 How parameter set inputs are evaluated

Parameter Set	PS1 (16-18)	PS2 (17-18)
---------------	-------------	-------------

Table 16 How parameter set inputs are evaluated

1	Open	Open
2	Closed	Open
3	Open	Closed
4	Closed	Closed

It is possible to use just one digital input to change between two parameter sets. According to the example above, digital input 3 is configured for PS1. If no digital input is configured for PS2, PS2 is considered to be open. In this case digital input 3 can be used to change between parameter set 1 and 2.

Changing the parameter set via external signal is only executed in stopped mode and at full voltage operation. If the input signals for PS1 and PS2 are changed during acceleration or deceleration, only the new parameters for the control source (menu [200]), the analogue/digital input (menu [500]), the edges digital input (menu [501]), the analogue start/stop on- and off-value (menus [502] and [503]) and the analogue start/stop delay (menu [504]) are loaded immediately. All other parameters will not change until the softstarter is in stopped mode or at full voltage running. In this way a change of the control source will take effect immediately, which can be useful for changing from remote to manual operation for maintenance.

NOTE: No parameters, except for the control source in menu [200] and the parameter set in menu [240], may be changed if external control of parameter set is activated in menu [240] (alternative 0).

8.10 View operation

MSF 2.0 includes numerous viewing functions which eliminate the need for additional transducers and meters for monitoring the operation.

[700] to [716] Operation (current, voltage, power etc.)

[720] to [725] Status (softstart status, input/output status)

[730] to [732] Stored values (operation time etc.)

8.10.1 Operation

RMS current

700	Read-out
0.0	Current
Range:	0.0-9999 A

NOTE: This is the same read-out as menu [100].

Line main voltage

701	Read-out
0	Line main voltage
Range:	0-720 V

Power factor

702	Read-out
0.00	Power factor
Range:	0.00-1.00

Output shaftpower

The output shaft power is shown in kW or in HP depending on the setting for Enable US units in menu [202].

703	Read-out
0.0	Output shaftpower
Range:	-999-9999 kW or HP

Output shaftpower in percentage unit

704 ^o	Read-out
<input type="text"/> <input type="text"/> <input type="text"/> 0	Output shaftpower in percentage units
Range:	0-200% of P_n

NOTE: This is the same read-out as menu [413].

Shaft torque

The shaft torque is shown in Nm or in lbft depending on the setting for Enable US units in menu [202].

705 ^o	Read-out
<input type="text"/> <input type="text"/> 0.0	Shaft torque
Range:	-999-9999 Nm or lbft

Shaft torque in percentage unit

706 ^o	Read-out
<input type="text"/> <input type="text"/> <input type="text"/> 0	Shaft torque in percentage units
Range:	0-250% of T_n

Softstarter temperature

The softstart temperature is shown in degrees Celsius or in degrees Fahrenheit depending on the setting for Enable US units in menu [202].

707 ^o	Read-out
<input type="text"/> <input type="text"/> L O	Softstarter temperature
Range:	Low, 30-96°C or low, 85-204°F

Current phase I1

708 ^o	Read-out
<input type="text"/> <input type="text"/> 0.0	Current phase L1
Range:	0.0-9999 A

Current phase L2

709 ^o	Read-out
<input type="text"/> <input type="text"/> 0.0	Current phase L2
Range:	0.0-9999 A

Current phase L3

710 ^o	Read-out
<input type="text"/> <input type="text"/> 0.0	Current phase L3
Range:	0.0-9999 A

Line main voltage L1-L2

711 ^o	Read-out
<input type="text"/> <input type="text"/> <input type="text"/> 0	Line main voltage L1-L2
Range:	0-720 V

Line main voltage L1-L3

712	Read-out
Line main voltage L1-L3	
0	
Range:	0-720 V

Line main voltage L2-L3

713	Read-out
Line main voltage L2-L3	
0	
Range:	0-720 V

Phase sequence

714	Read-out
Phase sequence	
L - - -	
Range:	L-, L123, L321

Used thermal capacity

715	Read-out
Used thermal capacity	
0	
Range:	0-150%

Time to next allowed start

716	Read-out
Time to next allowed start	
0	
Range:	0-60 min

8.10.2 Status

Softstarter status

720	Read-out
Softstarter status	
0	
Range:	1-12
1	Stopped, no alarm
2	Stopped, alarm
3	Run with alarm
4	Acceleration
5	Full voltage
6	Deceleration
7	Bypassed
8	PFC
9	Braking
10	Slow speed forward
11	Slow speed reverse
12	Standby (waiting for Analogue start/stop or Auto reset)

Digital Input Status

Status of the digital inputs 1- 4 from left to right. L or H are displayed for input status low (open) or high (closed).

721	Read-out
Digital input status	
L L L L	
Range:	LLLL-HHHH

Analogue/digital Input status

Status of the analogue/digital input when it is used as digital input. L and H are displayed for input status low (open) and high (closed).

722	Read-out
Analogue/digital input status	
L	
Range:	L, H

Analogue/digital input value

Value on the analogue/digital input as a percentage of the input range. This read-out depends on the configuration of the analogue/digital input in menu [500], e.g. if the analogue/digital input is configured for analogue start/stop 0-10 V/0-20 mA (alternative 6), an input signal of 4 V or 8 mA will be shown as 40%. However, if the analogue/digital input is configured for analogue start/stop 2.10 V/4-20 mA (alternative 7), an input signal of 4 V or 8 mA will be shown as 25%.

723	Read-out
Analogue/digital input value	
0	
Range:	0-100%

Relay status

Status of the relays K1 to K3 from the left to the right. L or H are displayed for relay status low (opened) or high (closed). The status described for relay K3 corresponds to the status of terminals 31 and 32.

724	Read-out
Relay status	
L L L	
Range:	LLL-HHH

Analogue Output value

Value on the analogue output as a percentage of the output range. This read-out depends on the configuration of the analogue output in menu [520], e.g. if the analogue/digital input is configured for 0-10 V/0-20 mA (alternative 1) or for 10-0 V/20-0 mA (alternative 3), an output signal of 4 V or 8 mA will be shown as 40%. However, if the analogue output is configured for 2-10 V/4-20 mA (alternative 2) or 10-2 V/20-4 mA (alternative 4), an output signal of 4 V or 8 mA will be shown as 25%.

725	Read-out
Analogue Output value	
0	
Range:	0-100%

8.10.3 Stored values

Operation time. The operation time is the time during which the motor connected to the softstarter is running, not the time during which the supply power is on.

If the actual value for the operation time exceeds 9999 hours the display will alternate between the four lower digits and the higher digits.

Example

If the actual operation time is 12467, 1 will be shown for 1 s, then 2467 will be shown for 5 s and so on.

730	Read-out
Operation time	
0	
Range:	0-9 999 999 h

Energy consumption

731	Read-out
Energy consumption	
0.000	
Range:	0.000-2000 MWh

Reset energy consumption

In this menu the stored power consumption (menu [713]) can be reset to 0.

732	Multi Setting
Reset energy consumption	
no	
Default:	no
Range:	no, YES
no	No action
YES	Reset power consumption

8.11 Alarm list

The alarm list is generated automatically. It shows the latest 15 alarms (F1-F17). The alarm list can be useful for tracking failures in the softstarter or its control circuit. In the alarm list both the alarm message and the operation time is saved for each alarms that occurs. In menu [800] the latest alarm message and the corresponding operation time are shown alternately, in the same way, older alarms are shown in menus [801] to [814].

Example

- If the latest alarm was a phase input failure (F1), which occurred at operation time 524. F1 is shown for 4 s then 524 is shown for 2 s and so on.
- If the latest alarm was a thermal motor protection alarm (F2), which occurred at operation time 17852. F2 is shown for 3 s, after that 1 is shown for 1 s, then 7852 is shown for 2 s and so on.

Alarm list, latest error

800	Read-out
Alarm list, latest error	
F 1	
Range:	F1-F17

Alarm list, error

801	Read-out
Alarm list, error 14	
F 1	
Range:	F1-F17

Menu	Function
802	Alarm list, error 13
803	Alarm list, error 12
804	Alarm list, error 11
805	Alarm list, error 10
806	Alarm list, error 9
807	Alarm list, error 8
808	Alarm list, error 7
809	Alarm list, error 6
810	Alarm list, error 5
811	Alarm list, error 4
812	Alarm list, error 3
813	Alarm list, error 2
814	Alarm list, error 1

8.12 Softstarter data

In menus [900] to [902] the softstarter type is shown and the softstarter's software version is specified.

Softstarter type

900	Read-out
Softstarter type	
1 7	
Range:	17-1400 A

Software variant

901	Read-out
Software variant text	
V 2 2 0	
Range:	Same as label

Software version

902	Read-out
Software version text	
R 1 5	
Range:	Same as label

9. Protection and alarm

MSF 2.0 is equipped with functions for motor protection, process protection and protection of the softstarter itself.

9.1 Alarm codes

Different alarm codes are used for the different errors, see Table 17 for a description of the alarm codes used. When an alarm occurs, this is indicated with the appropriate alarm message flashing in the display. If more than one alarm is active at the same time, the alarm code for the last alarm is presented on the display. The alarm code for each occurring alarm is also saved in the alarm list in menus [800] to [814].

9.2 Alarm actions

For most protection methods a proper action can be chosen to be performed if the relevant alarm occurs. The following alternatives are available as alarm actions (all alternatives may not be available for all protection methods - check Table 17):

Off

The alarm is deactivated.

Warning

The appropriate alarm code is flashing in the display and relay K3 is activated (for default configuration of the relays) if an the alarm occurs. However, the motor is not stopped and operation continues. The alarm message in the display will disappear and the relay will be reset when the alarm has disappeared. The alarm may also be reset manually. This setting alternative may be useful if it is desired to control operation in alarm state by an external control unit.

Coast

The appropriate alarm code is flashing in the display and relay K3 is activated (for default configuration of the relays) if an the alarm occurs. The motor voltage is automatically switched off. The motor is freewheels until it stops.

This setting alternative is useful if continuous running or active stopping could harm the process or the motor. This may be applicable for applications with very high inertia that use braking as the normal stop method. In this case it may be a good idea to choose Coast as alarm action on thermal motor protection alarm, because continuous running or braking could harm the motor seriously when this alarm has occurred.

Stop

The appropriate alarm code is flashing in the display and relay K3 is activated (for default configuration of the relays) if an alarm occurs. The motor is stopped according to the stop settings in menus [320] to [325].

This setting is useful for applications where a correct stop is important. This may apply to most pump applications, as Coast as an alarm action could cause water hammer.

Alarm Brake

The appropriate alarm code is flashing in the display and relay K3 is activated (for default configuration of the relays) if an alarm occurs. The brake function is activated according to the braking method chosen in menu [323] and the motor is stopped according to the alarm brake settings in menus [326] to [327] (braking strength and braking time). If alarm braking is deactivated in menu [326] and Alarm Brake is chosen as an alarm action, the action will be the same as described above for Coast.

Alarm Brake as an alarm action may mainly be used in combination with External alarm, where an external signal is used to initiate a quick stop with a higher braking strength and a shorter braking time compared to normal operation.

Spinbrake

The functionality for the Spinbrake alternative is the same as described above for the Alarm Brake alternative. However, if Spinbrake is chosen, braking can also be initiated from an inactive state. This means the softstarter can catch a freewheeling motor and brake it down to standstill.

The Spinbrake alternative is only available for External alarm. It may be useful e.g. for test running of planers and bandsaws after tool exchange. It may be desirable to accelerate the tool up to a specific speed and then leave it coasting to check if there is any unbalance. In this case it is possible to activate braking immediately by opening the external input.

In Table 17 below the alarm actions available for each alarm type are specified in detail.

9.3 Reset

For the following explanations it is important to distinguish between Reset and Restart. Reset means that the alarm message on the display disappears and the alarm relay K3 (for default configuration of the relays) is deactivated. If the operation has been interrupted due to an alarm the softstarter is prepared for a Restart. However, giving a Reset signal without giving a new start signal will never lead to a start.

The Reset signal can be given via control panel, remotely or via serial communication depending on the control source chosen in menu [200]. Regardless of the chosen control method, it is always possible to give a Reset signal via control panel.

If an alarm occurs whose alarm action is configured for Warning (see description of alarm actions above), the alarm will automatically be reset as soon as the failure disappears. The alarm may also be reset manually by giving a Reset signal as described above.

If operation has been interrupted due to an alarm, a Reset signal and a new start signal may be needed to Restart the motor. However, some alarms are automatically reset when a

new start signal is given. Table 17 covers all alarm types and whether they need a Reset signal (manual reset) or if they are reset automatically when a new start signal is given.

An alarm can always be reset by giving a Reset signal, even if the failure that caused the alarm has not disappeared yet. Giving a Reset will cause the alarm message on the display to disappear and the alarm relay K3 to be deactivated (for default configuration of the relays). However, if operation

has been interrupted due to an alarm, a Restart will not be possible until the failure has disappeared. If a new start signal is given while the failure still is active, the alarm message will appear flashing in the display and the alarm relay K3 will be activated again (for default configuration of the relays).

MSF 2.0 is also provided with an Auto reset function. This functionality is described in detail in section 8.5, page 52.

9.4 Alarm overview

Table 17 Alarm overview

Alarm code	Alarm description	Alarm action	Protection system	Reset
F1	Phase input failure.	Warning Coast	Motor protection (menu [230])	Automatic Reset when new start signal is given.
F2	Thermal motor protection	Off Warning Coast Stop Alarm Brake	Motor protection (menu [220])	Separate Reset signal needed.
F3	Soft start overheated	Coast		Separate Reset signal needed.
F4	Current limit start time expired.	Off Warning Coast Stop Alarm Brake	Motor protection (menu [231])	Automatic Reset when new start signal is given.
F5	Locked rotor alarm.	Off Warning Coast	Motor protection (menu [228])	Separate Reset signal needed.
F6	Max power alarm.	Off Warning Coast Stop Alarm Brake	Process protection (menu [400])	Separate Reset signal needed.
F7	Min power alarm.	Off Warning Coast Stop Alarm Brake	Process protection (menu [401])	Separate Reset signal needed.
F8	Voltage unbalance alarm.	Off Warning Coast Stop Alarm Brake	Process protection (menu [430])	Automatic Reset when new start signal is given.
F9	Overvoltage alarm.	Off Warning Coast Stop Alarm Brake	Process protection (menu [433])	Automatic Reset when new start signal is given.
F10	Undervoltage alarm.	Off Warning Coast Stop Alarm Brake	Process protection (menu [436])	Automatic Reset when new start signal is given.

Table 17 Alarm overview

Alarm code	Alarm description	Alarm action	Protection system	Reset
F11	Start limitation.	Off Warning Coast	Motor protection (menu [224])	Automatic Reset when new start signal is given.
F12	Shorted thyristor.	Coast		Separate Reset signal needed.
F13	Open thyristor.	Coast		Separate Reset signal needed.
F14	Motor terminal open.	Coast		Separate Reset signal needed.
F15	Serial communication contact broken.	Off Warning Coast Stop Alarm Brake	Control source protection (menu [273])	Automatic Reset when new start signal is given.
F16	Phase reversal alarm.	Off Warning Coast	Process protection (menu [440])	Separate Reset signal needed.
F17	External alarm.	Off Warning Coast Stop Alarm Brake Spinbrake	Process protection (menu [420])	Separate Reset signal needed.

10. Troubleshooting

10.1 Fault, cause and solution

Observation	Fault indication	Cause	Solution
Parameter will not be accepted.	----	If parameter 240, "Parameter set" is set to "0", the system is configured for external control of parameter set. Most parameters are not allowed to be changed in this mode.	Set parameter 240, "Parameter set" to a value between "1" - "4" and then any parameter can be changed.
		During start, stop and slow speed changing parameters is not permitted.	Set parameters during standstill or full voltage running.
		If control source is serial comm., it is impossible to change parameters from keyboard and vice versa.	Change parameters from the actual control source.
		Some menus include only read-out values and not parameters.	Read-out values cannot be altered. In Table 15, read-out menus have '---' in the factory setting column.
	-Loc	Control panel is locked for settings.	Unlock control panel by pressing the keys "NEXT" and "ENTER" for at least 3 sec.
The display is not illuminated.	None	No control supply voltage.	Switch on the control supply voltage.
The motor does not run.	F1 (Phase input failure)	Fuse defective.	Renew the fuse.
		No mains supply.	Switch on the mains supply.
	F2 (Thermal motor protection)	PTC connection could be open. Incorrect nominal motor current could be entered in menu [211].	Check the PTC input if PTC protection is used. If internal thermal motor protection is used, perhaps an other internal thermal protection class could be used (menu [222]). Cool down the motor and restart.
	F3 (Softstarter overheated)	Ambient temperature too high. Softstarter duty cycle exceeded. Could be fan failure.	Check ventilation of cabinet. Check the size of the cabinet. Clean the cooling fins. If the fan(s) is (are) not working correctly, contact your local MSF sales outlet.
	F4 (Current limit start time expired)	Current limit parameters are perhaps not matched to the load and motor.	Increase the start time (menu [315]) and/or the current limit at start (menu [314]).
	F5 (Locked rotor)	Something stuck in the machine or perhaps motor bearing failure.	Check the machine and motor bearings. Perhaps the Locked rotor time can be set longer (menu [229]).
	F6 (Max power alarm)	Overload	Check the machine. Perhaps the Max power alarm response delay can be set longer menu [404].
	F7 (Mn power alarm)	Underload	Check the machine. Perhaps the Min power alarm response delay can be set longer menu [410].
F8 (Voltage unbalance)	Mains supply voltage unbalance.	Check mains supply.	

Observation	Fault indication	Cause	Solution
The motor does not run.	F9 (Overvoltage)	Mains supply overvoltage.	Check mains supply.
	F10 (Undervoltage)	Mains supply undervoltage.	Check mains supply.
	F11 (Start limitation)	Number of starts per hour exceeded, min time between starts not kept.	Wait and start again. Perhaps the number of starts per hour could be increased in menu [225] or the min time between starts could be decreased (menu [226]).
	F13 (Open thyristor)	Perhaps a damaged thyristor.	Initiate a reset and a restart. If the same alarm appears immediately, contact your local MSF sales outlet.
	F14 (Motor terminal open)	Open motor contact, cable or motor winding.	If the fault is not found, reset the alarm and inspect the alarm list. If alarm F12 is found, a thyristor is probably shorted. Initiate a restart. If alarm F14 appears immediately, contact your local MSF sales outlet.
	F15 (Serial communication contact broken)	Serial communication contact broken.	Initiate a reset and try to establish contact. Check contacts, cables and option board. Verify - Serial communication unit address [270]. - Baudrate menu [271]. - Parity menu [272]. If the fault is not found, run the motor from the control panel if urgent set parameter [200] to 1. See also manual for serial communication.
	F16 (Phase reversal)	Incorrect phase sequence on main supply.	Switch L2 and L3 input phases.
	F17 (External alarm)	External alarm signal input open	Check the digital input configured for External alarm. Check the configuration of the digital inputs (menus [510] to [513]).
----	Start command comes perhaps from incorrect control source. (i.e. start from control panel when remote control is selected).	Give start command from correct control source as configured in menu [200].	
The motor is running but an alarm is given.	F1 (Phase input failure)	Failure in one phase. Perhaps fuse is defective.	Check fuses and mains supply. Select a different alarm action for Single phase input failure in menu [230] if stop is desired at single phase loss.
	F4 (Current limit start time expired)	Current limit parameters are perhaps not matched to the load and motor.	Increase the start time (menu [315]) and/or the current limit at start (menu [314]). Select a different action for Current limit start time expired alarm in menu [231], if stop is desired at current limit time-out.

Observation	Fault indication	Cause	Solution
The motor is running but an alarm is given.	F12 (Shorted thyristor)	Perhaps a damaged thyristor.	When stop command is given, a freewheel stop is made. Initiate a reset and a restart. If alarm F14 appears immediately, contact your local MSF sales outlet. If the motor must be started urgently, the softstarter can start the motor direct on-line (DOL). Set the start method to DOL in this case (parameter [310]=4).
		Bypass contactor is used but parameter [340] 'Bypass' is not set to "on".	Set parameter [340] Bypass to on.
	F15 (Serial communication contact broken)	Serial communication contact broken.	Initiate a reset and try to establish contact. Check contacts, cables and option board. Verify - Serial communication unit address [270]. - Baudrate [271]. - Parity [272]. If the fault is not found, run the motor from the control panel if urgent, see also manual for serial communication.
The motor jerks etc.	When starting, motor reaches full speed but it jerks or vibrates.	If "Torque control" or "Pump control" is selected, it is necessary to input motor data into the system.	Configure nominal motor data in menus [210]-[215]. Select the proper torque control alternative in menu [310] (linear or square) according to the load characteristic. Select a correct initial- and end torque at start in menus [311] and [312]. If 'Bypass' is selected, check that the current transformers are correctly connected.
		Start time too short.	Increase start time [315].
		If voltage control is used as start method, the initial voltage at start may be too low. Starting voltage incorrectly set.	Adjust initial voltage at start [311].
		Motor too small in relation to rated current of softstarter.	Use a smaller model of the softstarter.
		Motor too large in relation to load of softstarter.	Use larger model of softstarter.
		Starting voltage not set correctly.	Readjust the start ramp. Select the current limit function.
	Starting or stopping time too long.	Ramp times not set correctly.	Readjust the start and/or stop ramp time.
		Motor too large or too small in relation to load.	Change to another motor size.
The monitor function does not work.	No alarm or pre-alarm	It is necessary to input nominal motor data for this function. Incorrect alarm margins or normal load.	Input nominal motor data in menus [210]-[215]. Adjust alarm margins and normal load in menus [402] - [412]. Use Auto set [411] if needed. If a Bypass contactor is used, check that the current transformers are correctly connected.

Observation	Fault indication	Cause	Solution
Unexplainable alarm.	F5, F6, F7, F8, F9, F10	Alarm delay time is too short.	Adjust the response delay times for the alarms in menus [229], [404], [410], [432], [435] and [438].
The system seems locked in an alarm.	F2 (Thermal motor protection)	PTC input terminal could be open. Motor could still be too warm. If internal motor protection is used, the cooling in the internal model may take some time.	PTC input terminal should be short circuit if not used. Wait until motor PTC gives an OK (not overheated) signal. Wait until the internal cooling is done. Try to restart after a while.
	F3 (Softstarter overheated)	Ambient temperature too high. Perhaps fan failure.	Check that cables from power part are connected in terminals 71 to 74. MSF-017 to MSF-250 should have a jumper between terminals 71 and 72. Check also that the fan(s) is (are) rotating.

11. Maintenance

In general the softstarter is maintenance-free. There are however some things which should be checked regularly. In particular, if the surroundings are dusty the unit should be cleaned regularly.



WARNING!

Do not touch parts inside the enclosure of the unit when the control supply voltage or the mains supply voltage is switched on.

11.1 Regular maintenance

- Check that nothing in the softstarter has been damaged by vibration (loose screws or connections).
- Check external wiring, connections and control signals. Tighten terminal screws and busbar bolts if necessary.
- Check that printed circuit boards, thyristors and cooling fins are free from dust. Clean with compressed air if necessary. Make sure the printed circuit boards and the thyristors are undamaged.
- Check for signs of overheating (changes in colour on printed circuit boards, oxidation of solder points etc.). Check that the temperature is within permissible limits.
- Check that the cooling fan(s) permit free air flow. Clean any external air filters if necessary.

12. Options

The following options are available. Please contact your supplier for more detailed information.

12.1 Serial communication

For serial communication the MODBUS RTU (RS232/RS485) option board is available, order part number: 01-1733-00. The softstarter MSF 2.0 can also be ordered with the MODBUS RTU (RS232/RS485) option mounted, for ordering information see chapter 1.5 page 6

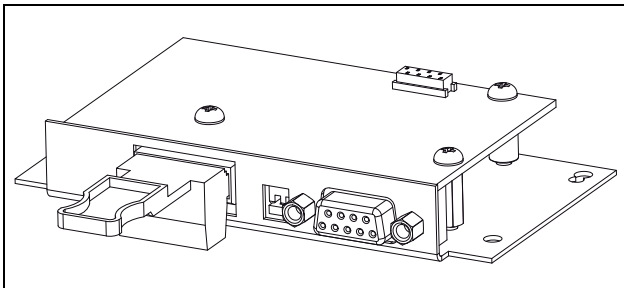

Fig. 70 Option RS232/485

12.2 Fieldbus systems

Various option boards are available for the following bus systems:

- PROFIBUS DP order part number: 01-1734-01
- Device NET, order part number: 01-1736-01

Each system has its own board. The option is delivered with an instruction manual containing all the details for the installation and set-up of the board and the protocol for programming. The softstarter MSF 2.0 can also be ordered with a fieldbus option mounted, for ordering information see chapter 1.5 page 6

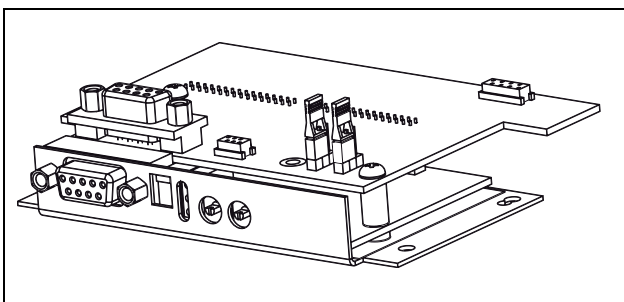

Fig. 71 Profibus Option

12.3 External control panel

The external control panel option is used to move the control panel from the softstarter to the front of a panel door or control cabinet.

The maximum distance between the softstarter and the external control panel is 3 m.

The part number to order for the external control panel is 01-3060-00. A separate data sheet for this option is available. The softstarter MSF 2.0 can also be ordered with the external control panel mounted, for ordering information see chapter 1.5 page 6

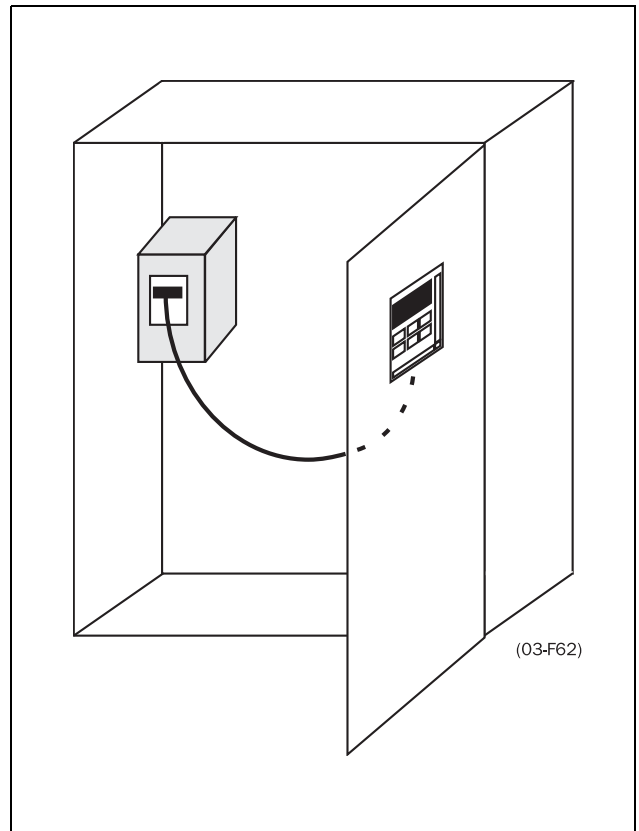

Fig. 72 Use of the external control panel.

12.3.1 Cable kit for external current transformers

This kit is used for the bypass function, to connect the current transformers externally. order part number: 01-2020-00.

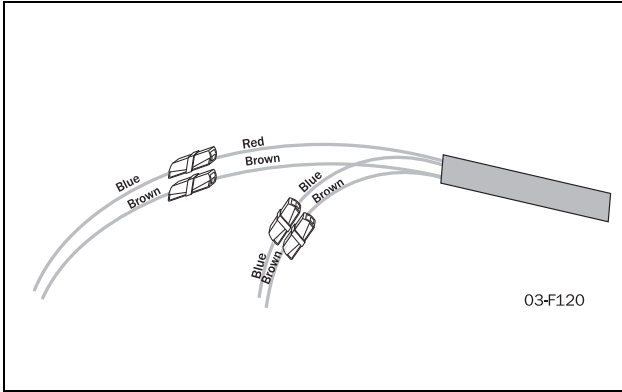

Fig. 73 Cable kit

12.4 Terminal clamp

Data: Single cables, Cu or Al

Cables	95-300 mm ²
MSF type Cu Cable	310
Bolt for connection to busbar	M10
Dimensions in mm	33x84x47 mm
Part no. single	9350

Data: Parallel cables, Cu or Al

Cables	2x95-300 mm ²
MSF type and Cu Cable	310 to 835
Bolt for connection to busbar	M10
Dimensions in mm	35x87x65
Part no. parallel	9351

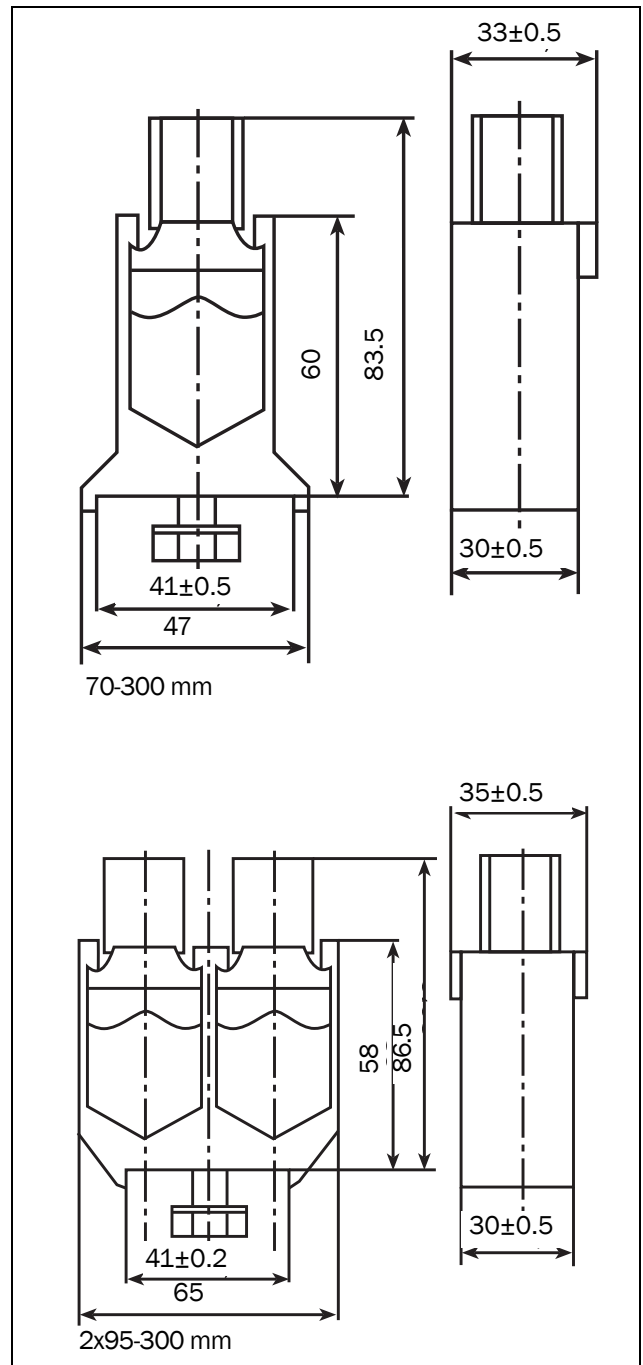

Fig. 74 The terminal clamp.

12.5 IT-net option

The MSF softstarters can be ordered with IT-net option. This option covers the configuration of the mains supply connection for IT-net.

The control supply connection of the MSF softstarters can be configured for normal or IT connection by adjusting jumper J3.

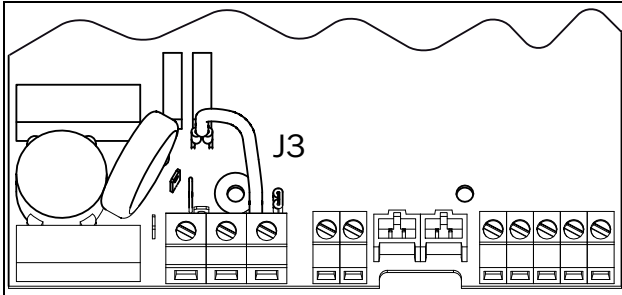

Fig. 75 Default setting of jumper J3.

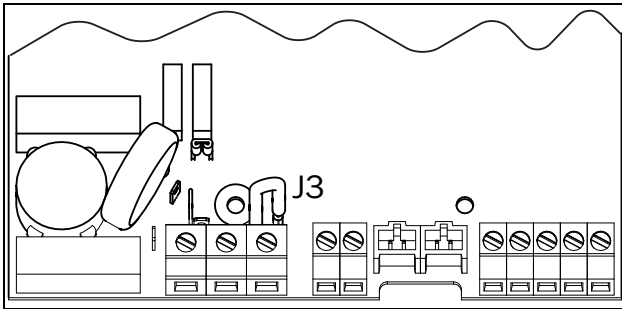

Fig. 76 Setting of jumper J3 for control supply with IT connection.

With the IT-net option, outer measures on the mains supply are required to fulfil EMC-regulations. The same applies for the control supply if the jumper is set for IT-net.

13. Technical data

13.1 Electrical specifications

Table 18 Typical motor power at mains voltage 400 V

MSF model	Heavy AC-53a 5.0-30:50-10		Normal AC-53a 3.0-30:50-10		Normal with bypass AC-53b 3.0-30:300	
	Power @400V [kW]	Rated current [A]	Power @400V [kW]	Rated current [A]	Power @400V [kW]	Rated current [A]
MSF-017	7.5	17	11	22	11	25
-030	15	30	18.5	37	22	45
-045	22	45	30	60	37	67
-060	30	60	37	72	45	85
-075	37	75	45	85	55	103
-085	45	85	45	96	55	120
-110	55	110	75	134	90	165
-145	75	145	75	156	110	210
-170	90	170	110	210	132	255
-210	110	210	132	250	160	300
-250	132	250	132	262	200	360
-310	160	310	200	370	250	450
-370	200	370	250	450	315	555
-450	250	450	315	549	355	675
-570	315	570	400	710	450	820
-710	400	710	450	835	500	945
-835	450	835	500	960	630	1125
-1000	560	1 000	630	1125	800	1400
-1400	800	1 400	900	1650	1000	1800

Table 19 Typical motor power at mains voltage 460 V

MSF model	Heavy AC-53a 5.0-30:50-10		Normal AC-53a 3.0-30:50-10		Normal with bypass AC-53b 3.0-30:300	
	Power @460V [hp]	Rated current [A]	Power @460V [hp]	Rated current [A]	Power @460V [hp]	Rated current [A]
MSF-017	10	17	15	22	20	25
-030	20	30	25	37	30	45
-045	30	45	40	60	50	68
-060	40	60	50	72	60	85
-075	60	75	60	85	75	103
-085	60	85	75	96	100	120
-110	75	110	100	134	125	165
-145	100	145	125	156	150	210
-170	125	170	150	210	200	255
-210	150	210	200	250	250	300
-250	200	250	200	262	300	360
-310	250	310	300	370	350	450
-370	300	370	350	450	450	555
-450	350	450	450	549	500	675
-570	500	570	600	710	650	820
-710	600	710	700	835	800	945
-835	700	835	800	960	900	1125
-1000	800	1 000	900	1125	1000	1400
-1400	1000	1 400	1250	1650	1500	1800

Table 20 Typical motor power at mains voltage 525 V

MSF model	Heavy AC-53a 5.0-30:50-10		Normal AC-53a 3.0-30:50-10		Normal with bypass AC-53b 3.0-30:300	
	Power @525V [kW]	Rated current [A]	Power @525V [kW]	Rated current [A]	Power @525V [kW]	Rated current [A]
MSF-017	11	17	15	22	15	25
-030	18,5	30	22	37	30	45
-045	30	45	37	60	45	68
-060	37	60	45	72	55	85
-075	45	75	55	85	75	103
-085	55	85	55	96	75	120
-110	75	110	90	134	110	165
-145	90	145	110	156	132	210
-170	110	170	132	210	160	255
-210	132	210	160	250	200	300
-250	160	250	160	262	250	360
-310	200	310	250	370	315	450
-370	250	370	315	450	355	555
-450	315	450	400	549	450	675
-570	400	570	500	710	560	820
-710	500	710	560	835	630	945
-835	560	835	710	960	800	1125
-1000	710	1 000	800	1125	1000	1400
-1400	1000	1 400	1250	1650	1400	1800

Table 21 Typical motor power at mains voltage 575 V

MSF model	Heavy AC-53a 5.0-30:50-10		Normal AC-53a 3.0-30:50-10		Normal with bypass AC-53b 3.0-30:300	
	Power @575V [hp]	Rated current [A]	Power @575V [hp]	Rated current [A]	Power @575V [hp]	Rated current [A]
MSF-017	15	17	20	22	25	25
-030	25	30	30	37	40	45
-045	40	45	50	60	60	68
-060	50	60	60	72	75	85
-075	75	75	75	85	100	103
-085	75	85	75	90	125	120
-110	100	110	125	134	150	165
-145	150	145	150	156	200	210
-170	150	170	200	210	250	255
-210	200	210	250	250	300	300
-250	250	250	250	262	350	360
-310	300	310	400	370	450	450
-370	400	370	500	450	600	555
-450	500	450	600	549	700	675
-570	600	570	700	640	800	820
-710	700	710	800	835	1000	945
-835	800	835	900	880	1250	1125
-1000	1000	1 000	1250	1125	1500	1400
-1400	1500	1 400	1500	1524	2000	1800

Table 22 Typical motor power at mains voltage 690 V

MSF model	Heavy AC-53a 5.0-30:50-10		Normal AC-53a 3.0-30:50-10		Normal with bypass AC-53b 3.0-30:300	
	Power @690V [kW]	Rated current [A]	Power @690V [kW]	Rated current [A]	Power @690V [kW]	Rated current [A]
MSF-017	15	17	18,5	22	22	25
-030	22	30	30	37	37	45
-045	37	45	55	60	55	68
-060	55	60	55	72	75	85
-075	55	75	75	85	90	103
-085	75	85	90	90	110	120
-110	90	110	110	134	160	165
-145	132	145	132	156	200	210
-170	160	170	200	210	250	255
-210	200	210	250	250	250	300
-250	250	250	250	262	355	360
-310	315	310	355	370	400	450
-370	355	370	400	450	500	555
-450	400	450	560	549	630	675
-570	560	570	630	640	800	820
-710	710	710	800	835	900	945
-835	800	835	900	880	1120	1125
-1000	1000	1 000	1120	1125	1400	1400
-1400	1400	1 400	1600	1524	1800	1800

13.2 General electrical specifications

Table 23 General electrical specifications

Parameter	Description
General	
Mains supply voltage	200-525 V $\pm 10\%$ 200-690 V +5%, -10%
Control supply voltage	100-240 V $\pm 10\%$ 380-500 V $\pm 10\%$
Mains and Control supply frequency	50/60 Hz $\pm 10\%$
Number of fully controlled phases	3
Recommended fuse for control supply	Max 10 A
Control signal inputs	
Digital input voltage	0-3 V \rightarrow 0, 8-27 V \rightarrow 1. Max 37 V for 10 sec.
Digital input impedance to GND (0 VDC)	2.2 k Ω
Analogue input voltage/current	0-10 V, 2-10 V, 0-20 mA, 4-20 mA
Analogue input impedance to GND (0 VDC)	Voltage signal 125 k Ω , current signal 100 Ω
Control signal outputs	
Output relays contact	8 A, 250 VAC or 24 VDC resistive load; 3 A, 250 VAC inductive load (PF 0.4)
Analogue output voltage/current	0-10 V, 2-10 V, 0-20 mA, 4-20 mA
Analogue output load impedance	Voltage signal min load 700 Ω , current signal max load 750 Ω
Control signal supply	
+12 VDC	+12 VDC $\pm 5\%$. Max current 50 mA. Short circuit proof.

13.3 Fuses and power losses

Table 24 Fuses

Model	Fusing for UL		Fusing for cUL	
	Fuse type	Rating	Fuse type	Rating
MSF-017	Any UL listed fuse	max 80 A	Bussmann, FWP	max 80 A
-030	Any UL listed fuse	max 125 A	Bussmann, FWP	max 125 A
-045	Any UL listed fuse	max 225 A	Bussmann, FWP	max 150 A
-060	Any UL listed fuse	max 250 A	Bussmann, FWP	max 175 A
-075	Any UL listed fuse	max 300 A	Bussmann, FWP	max 250 A
-085	Any UL listed fuse	max 350 A	Bussmann, FWP	max 300 A
-110	Any UL listed fuse	max 500 A	Bussmann, FWP	max 350 A
-145	Any UL listed fuse	max 600 A	Bussmann, FWP	max 450 A
-170	Any UL listed fuse	max 800 A	Bussmann, FWP	max 700 A
-210	Any UL listed fuse	max 1000 A	Bussmann, FWP	max 700 A
-250	Any UL listed fuse	max 1000 A	Bussmann, FWP	max 800 A
-310	Any UL listed fuse or circuit breaker	max 1400 A	Any CSA listed fuse or circuit breaker	max 1400 A
-370	Any UL listed fuse or circuit breaker	max 1800 A	Any CSA listed fuse or circuit breaker	max 1800 A
-450	Any UL listed fuse or circuit breaker	max 2100 A	Any CSA listed fuse or circuit breaker	max 2100 A
-570	Any UL listed fuse or circuit breaker	max 2100 A	Any CSA listed fuse or circuit breaker	max 2100 A
-710	Any UL listed fuse or circuit breaker	max 2500 A	Any CSA listed fuse or circuit breaker	max 2500 A
-835	Any UL listed fuse or circuit breaker	max 2800 A	Any CSA listed fuse or circuit breaker	max 2800 A
-1000	-	-	-	-
-1400	-	-	-	-

NOTE: Short circuit withstand:
MSF-017-MSF-060 5000 rms A when used with K5 or RK5 fuses
MSF-075 - MSF-145 10000 rms A when used with K5 or RK5 fuses
MSF-170 - MSF-250 18000 rms A when used with K5 or RK5 fuses
MSF-310 18000 rms A
MSF-370 and MSF-450 30000 rms A
MSF-570, MSF-710 and MSF-835 42000 rms A

Table 25 Power losses

Model	Power loss at rated motor load [W] No losses with bypass		Power consumption control card [VA]
	Heavy	Normal	
MSF-017	50	70	20
-030	90	120	20
-045	140	180	25
-060	180	215	25
-075	230	260	25
-085	260	290	25
-110	330	400	25
-145	440	470	25
-170	510	630	35
-210	630	750	35
-250	750	750	35
-310	930	1100	35
-370	1100	1535	35
-450	1400	1730	35
-570	1700	2100	35
-710	2100	2500	35
-835	2500	2875	35
-1000	3000	3375	35
-1400	4200	4950	35

13.4 Mechanical specifications including mechanical drawings

MSF Model	Dimensions H*W*D [mm]	Mounting position [Vertical/Horizontal]	Weight [kg]	Connection busbars [mm]	PE screw	Cooling system	Protection class
-017, -030	320*126*260	Vertical	6.7	15*4, Cu (M6)	M6	Convection	IP20
-045	320*126*260	Vert. or Horiz.	6.9	15*4, Cu (M6)	M6	Fan	IP20
-060, -075, -085	320*126*260	Vert. or Horiz.	6.9	15*4, Cu (M8)	M6	Fan	IP20
-110, -145	400*176*260	Vert. or Horiz.	12	20*4, Cu (M10)	M8	Fan	IP20
-170, -210, -250	500*260*260	Vert. or Horiz.	20	30*4, Cu (M10)	M8	Fan	IP20
-310, -370, -450	532*547*278	Vert. or Horiz.	46	40*8, Al (M12)	M8	Fan	IP20
-570, -710, -835	687*640*302	Vert. or Horiz.	80	40*10, Al (M12)	M8	Fan	IP20
-1000, -1400	900*875*336	Vert. or Horiz.	175	80*10, Al (M12)		Fan	IP00

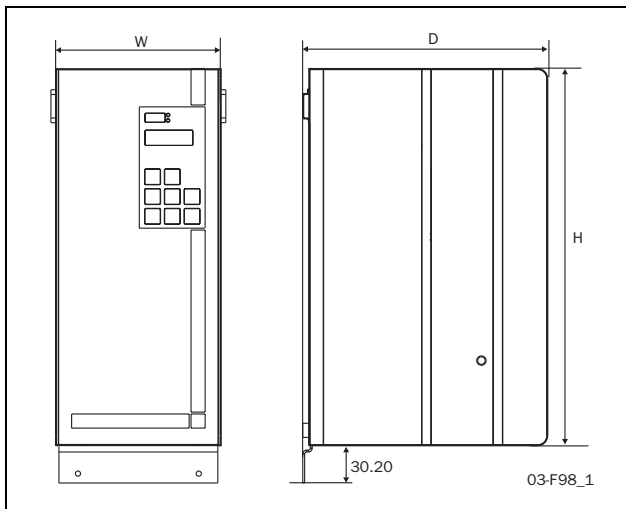

Fig. 77 MSF -017 to MSF -250.

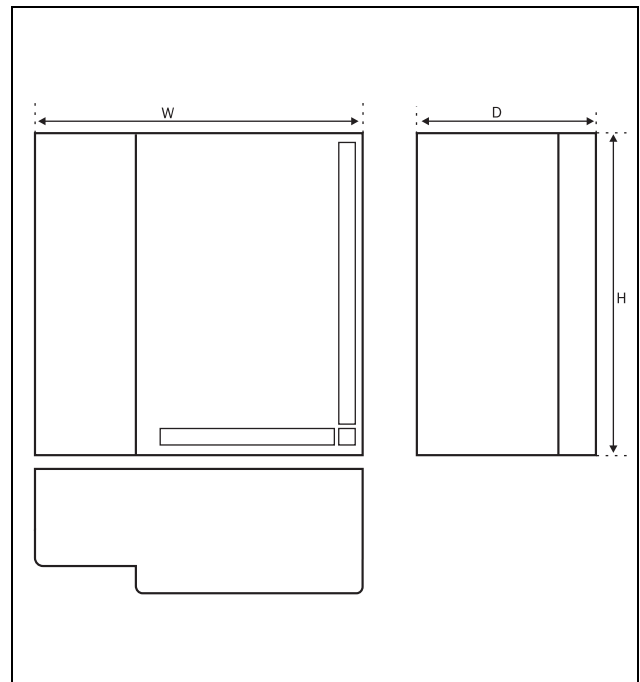

Fig. 78 MSF -310 to MSF -835.

13.5 Derating at higher temperature

By derating the current to 80% of nominal current, the MSF can be operated at an ambient temperature of up to 50 °C. E.g. a MSF-045 can operate a heavy load of 36 A (45 A*0.8).

13.6 Environmental conditions

Normal operation	
Temperature	0 - 40°C
Relative humidity	95%, non-condensing
Max altitude without derating	1000 m
Storage	
Temperature	-25 - +70°C
Relative humidity	95%, non-condensing

13.7 Standards

Market	Standard	Description
All	IEC 60947-1	Low voltage switch gear and control gear - Part 1: General rules.
	IEC 60947-4-2	Low voltage switch gear and control gear - Part 4-2: Contactors and motor starters - AC semiconductor motor controllers and starters
European	EMC Directive	2004/108/EC
	Low Voltage Directive	2006/95/EC
Russian	GOST R	Russian certificate of conformity
American	UL 508 CSA 22.2 No. 14	Industrial control equipment. UL: Models MSF-017 to MSF-835 up to 600 VAC (optional) cUL: Models MSF-017 to MSF-835 up to 600 VAC (optional)

Radiated and conducted emission: Class A (industrial environment). For class B (public environment) an external bypass has to be used.

13.8 Power- and signal connectors.

Table 26 PCB Terminals

Terminal	Function	Electrical characteristics
01	Control supply voltage	100-240 VAC $\pm 10\%$ alternative
02		380-500 VAC $\pm 10\%$ see rating plate
PE	Protective Earth	Protective Earth
11	Digital input 1	0-3 V \rightarrow 0; 8-27 V \rightarrow 1. Max. 37 V for 10 sec. Impedance to 0 VDC: 2.2 k Ω .
12	Digital input 2	
13	Control signal supply voltage to PCB terminal 11 and 12, 10 k Ω potentiometer, etc.	+12 VDC $\pm 5\%$. Max. current from +12 VDC: 50 mA. Short circuit-proof but not overload-proof.
14	Analogue input, 0-10 V, 2-10 V, 0-20 mA and 4-20 mA/digital input.	Impedance to terminal 15 (0 VDC) voltage signal: 125 k Ω , current signal: 100 Ω .
15	GND (common)	0 VDC
16	Digital input 3	0-3 V \rightarrow 0; 8-27 V \rightarrow 1. Max. 37 V for 10 sec. Impedance to 0 VDC: 2.2 k Ω .
17	Digital input 4	
18	Control signal supply voltage to PCB terminal 16 and 17, 10 k Ω potentiometer, etc.	+12 VDC $\pm 5\%$. Max. current from +12 VDC = 50 mA. Short circuit-proof but not overload-proof.
19	Analogue output	Analogue output contact: 0-10 V, 2-10 V; min load impedance 700 Ω 0-20 mA and 4-20 mA; max load impedance 750 Ω
21	Programmable relay K1. Factory setting is "Operation" with indication by closing terminal 21 to 22.	1-pole closing contact, 250 VAC 8 A or 24 VDC 8 A resistive, 250 VAC, 3 A inductive.
22		
23	Programmable relay K2. Factory setting is "Full voltage" with indication by closing terminals 23 to 24.	1-pole closing contact, 250 VAC 8 A or 24 VDC 8 A resistive, 250 VAC, 3 A inductive.
24		
31	Programmable relay K3. Factory setting is "All alarms". Indication by closing terminals 31 to 33 and opening terminals 32 to 33.	1-pole change-over contact, 250 VAC 8A or 24 VDC 8A resistive, 250 VAC, 3A inductive.
32		
33		
69-70	PTC Thermistor input	Alarm level 2.4 k Ω . Switch back level 2.2 k Ω .
71-72*	Clickson thermistor	Controlling softstarter cooling fan temperature MSF-310 - MSF-1400
73-74*	NTC thermistor	Temperature measuring of softstarter cooling fin
75	Current transformer input, cable S1 (blue)	Connection of L1 or T1 phase current transformer
76	Current transformer input, cable S1 (blue)	Connection of L3, T3 phase (MSF 017 to MSF 250) or L2, T2 phase (MSF 310 to MSF 1400)
77	Current transformer input, cable S2 (brown)	Common connection for terminals 75 and 76
78*	Fan connection	24 VDC
79*	Fan connection	0 VDC

*Internal connection, no customer use.

13.9 Semi-conductor fuses

Always use standard commercial fuses to protect the wiring and prevent short circuiting. To protect the thyristors against short-circuit currents, superfast semiconductor fuses can be used if preferred (e.g. Bussmann type FWP or similar, see table below).

Type	FWP/FWJ Bussmann fuse	
		I^2t (fuse) at 700 V
MSF-017	FWP-80A	2400
MSF-030	FWP-125A	7300
MSF-045	FWP-150A	11700
MSF-060	FWP-175A	16700
MSF-075	FWP-250A	42500
MSF-085	FWP-300A	71200
MSF-110	FWP-350A	95600
MSF-145	FWP-450A	250000
MSF-170	FWP-700A	300000
MSF-210	FWP-700A	300000
MSF-250	FWP-800A	450000
MSF-310	FWP-800A	450000
MSF-370	FWP-1000A	600000
MSF-450	FWJ-1200A	1470000
MSF-570	FWJ-1400A	1890000
MSF-710	FWJ-1800A	3710000
MSF-835	FWJ-2000A	5320000
MSF-1000	FWJ-2000A	5320000
MSF-1400		<12000000

14. Set-up menu list

Table 27 Parameter list

Menu no.	Function / Parameter	Range /Settings	Factory setting	Customer setting / Parameter set 1-4				Page
				1	2	3	4	
GENERAL SETTINGS								
100	Current	0.0 - 9999 A	Read-out					44
101	Automatic return menu	oFF, 1 - 999	oFF					44
200	Control source	1. Control panel 2. Remote control 3. Serial comm. control	2					44
201	Control panel locked for settings	oFF, on	oFF / Read-out					44
202	Enable US-units	oFF, on	oFF					45
MOTOR DATA								
210	Nominal motor voltage	200 - 700 V	400					45
211	Nominal motor current	25 - 200 % of I_{nsoft} in A	I_{nsoft}					45
212	Nominal motor power	25 - 400 % of P_{nsoft} in kW or hp	P_{nsoft}					45
213	Nominal motor speed	500 - 3600 rpm	n_{nsoft}					46
214	Nominal motor power factor	0.50 - 1.00	0.86					46
215	Nominal frequency	50, 60 Hz	50					46
MOTOR PROTECTION								
Thermal motor protection								
220	Thermal motor protection (alarm code F2)	oFF. Disabled 1. Warning 2. Coast 3. Stop 4. Alarm brake	2					46
221	PTC input	oFF, on	oFF					47
222	Internal protection class	oFF, 2 - 40 s	10					47
223	Used thermal capacity	0 - 150 %	Read-out					47
Start limitation								
224	Start limitation (Alarm code F11)	oFF. Disabled 1. Warning 2. Coast	oFF					48
225	Number of starts per hour	oFF, 1 - 99	oFF					49
226	Min. time between starts	oFF, 1 - 60 min	oFF					49
227	Time to next allowed start	0 - 60 min	Read-out					49
Locked rotor								
228	Locked rotor alarm (Alarm code F5)	oFF. Disabled 1. Warning 2. Coast	oFF					49
229	Locked rotor time	1.0 - 10.0 s	5.0					50
230	Single phase input failure (Alarm code F1)	1. Warning 2. Coast	2					50

Table 27 Parameter list

Menu no.	Function / Parameter	Range /Settings	Factory setting	Customer setting / Parameter set 1-4				Page
				1	2	3	4	
231	Current limit start time expired (Alarm code F4)	oFF. Disabled 1. Warning 2. Coast 3. Stop 4. Alarm brake	2					51
PARAMETER SET HANDLING								
240	Select parameter set	0. External control of parameter sets 1-4. Selection of parameter sets 1-4	1					51
241	Actual parameter set	1, 2, 3, 4	1 / Read-out					52
242	Copy parameter set	no, 1-2, 1-3, 1-4, 2-1, 2-3, 2-4, 3-1, 3-2, 3-4, 4-1, 4-2, 4-3	no					52
243	Reset to factory setting	no, YES	no					52
AUTO RESET								
250	Auto reset attempts	oFF, 1 - 10	oFF					53
251	Thermal motor protection auto reset	oFF, 1 - 3600 s	oFF					53
252	Start limitation auto reset	oFF, 1 - 3600 s	oFF					54
253	Locked rotor alarm auto reset	oFF, 1 - 3600 s	oFF					54
254	Current limit start time expired auto reset	oFF, 1 - 3600 s	oFF					54
255	Max power alarm auto reset	oFF, 1 - 3600 s	oFF					54
256	Min power alarm auto reset	oFF, 1 - 3600 s	oFF					54
257	External alarm auto reset	oFF, 1 - 3600 s	oFF					54
258	Phase input failure auto reset	oFF, 1 - 3600 s	oFF					54
259	Voltage unbalance alarm auto reset	oFF, 1 - 3600 s	oFF					54
260	Over voltage alarm auto reset	oFF, 1 - 3600 s	oFF					54
261	Under voltage alarm auto reset	oFF, 1 - 3600 s	oFF					54
262	Serial communication auto reset	oFF, 1 - 3600 s	oFF					55
263	Softstarter overheated auto reset	oFF, 1 - 3600 s	oFF					55
SERIAL COMMUNICATION								
270	Serial comm. unit adress	1 - 247	1					55
271	Serial comm. baudrate	2.4 - 38.4 kBaud	9.6					55
272	Serial comm. parity	0. No parity 1. Even parity	0					55
273	Serial comm. contact broken (Alarm code F15)	oFF. Disabled 1. Warning 2. Coast 3. Stop 4. Alarm brake	3					55

Table 27 Parameter list

Menu no.	Function / Parameter	Range /Settings	Factory setting	Customer setting / Parameter set 1-4				Page
				1	2	3	4	
OPERATION SETTINGS								
Presetting								
300	Preset pump control parameters	no, YES	no					56
Start								
310	Start method	1. Linear torque control 2. Square torque control 3. Voltage control 4. Direct on-line, DOL	1					57
311	Initial torque at start	0 - 250 % of T_n	10					58
312	End torque at start	25 - 250 % of T_n	150					58
313	Initial voltage at start	25 - 90 % of U	30					59
314	Current limit at start	oFF, 150 - 500 % of I_n	oFF					59
315	Start time	1 - 60 s	10					60
316	Torque boost current limit	oFF, 300 - 700 % of I_n	oFF					60
317	Torque boost active time	0.1 - 2.0 s	1.0					60
Stop								
320	Stop method	1. Linear torque control 2. Square torque control 3. Voltage control 4. Coast 5. Brake	4					61
321	End torque at stop	0 - 100 % of T_n	0					61
322	Step down voltage at stop	100 - 40 % of U	100					61
323	Braking method	1. Dynamic vector brake 2. Reverse current brake	1					64
324	Braking strength	150 - 500 %	150					64
325	Stop time	1 - 120 s	10					64
326	Alarm braking strength	oFF, 150 - 500 %	oFF					64
327	Alarm braking time	1 - 120 s	10					64
Slow speed / JOG								
330	Slow speed strength	10 - 100	10					67
331	Slow speed time at start	oFF, 1 - 60 s	oFF					67
332	Slow speed time at stop	oFF, 1 - 60 s	oFF					67
333	DC-brake at slow speed	oFF, 1 - 60 s	oFF					67
334	Jog forward enable	oFF, on	oFF					68
335	Jog reverse enable	oFF, on	oFF					68
Additional settings								
340	Bypass	oFF, on	oFF					68
341	Power Factor Control PFC	oFF, on	oFF					70
342	Fan continuously on	oFF, on	oFF					70

Table 27 Parameter list

Menu no.	Function / Parameter	Range /Settings	Factory setting	Customer setting / Parameter set 1-4				Page
				1	2	3	4	
PROCESS PROTECTION								
Shaft power monitor								
400	Max power alarm (Alarm code F6)	oFF. Disabled 1. Warning 2. Coast 3. Stop 4. Alarm brake	oFF					72
401	Min power alarm (Alarm code F7)	Same as menu 400	oFF					72
402	Start delay power alarms	1 - 999 s	10					72
403	Max power alarm margin	0 - 100 % of P _n	16					72
404	Max power alarm response delay	0.1 - 90.0 s	0.5					72
405	Max power pre-alarm margin	0 - 100 % of P _n	8					73
406	Max power pre-alarm response delay	0.1 - 90.0 s	0.5					73
407	Min power pre-alarm margin	0 - 100 % of P _n	8					73
408	Min power pre-alarm response delay	0.1 - 90.0 s	0.5					73
409	Min power alarm margin	0 - 100 % of P _n	16					73
410	Min power alarm response delay	0.1 - 90.0 s	0.5					74
411	Auto set	no, YES	no					74
412	Normal load	0 - 200 % of P _n	100					74
413	Output shaft power	0 - 200 % of P _n	Read-out					74
External alarm								
420	External alarm (Alarm code F17)	oFF. Disabled 1. Warning 2. Coast 3. Stop 4. Alarm brake 5. Spinbrake	oFF					74
Mains protection								
430	Voltage unbalance alarm (Alarm code F8)	oFF. Disabled 1. Warning 2. Coast 3. Stop 4. Alarm brake	oFF					75
431	Unbalance voltage level	2 - 25 % of U _n	10					76
432	Response delay voltage unbalance alarm	1 - 90 s	1					76
433	Overvoltage alarm (Alarm code F9)	oFF. Disabled 1. Warning 2. Coast 3. Stop 4. Alarm brake	oFF					76
434	Overvoltage level	100 - 150 % of U _n	115					76
435	Response delay overvoltage alarm	1 - 90 s	1					76

Table 27 Parameter list

Menu no.	Function / Parameter	Range /Settings	Factory setting	Customer setting / Parameter set 1-4				Page
				1	2	3	4	
436	Undervoltage alarm (Alarm code F10)	oFF. Disabled 1. Warning 2. Coast 3. Stop 4. Alarm brake	oFF					76
437	Undervoltage level	75 - 100 % of U_n	85					77
438	Response delay undervoltage alarm	1 - 90 s	1					77
439	Phase sequence	L123, L321, L--	Read-out					77
440	Phase reversal alarm (Alarm code F16)	oFF. Disabled 1. Warning 2. Coast	oFF					77
I/O SETTINGS								
Input signals								
500	Analogue / digital input	oFF. Disabled 1. Digital, Rotation sensor 2. Digital, Slow speed 3. Digital, Jog forward 4. Digital, Jog reverse 5. Digital, Auto set 6. Analogue start/stop, 0 10 V / 0 20 mA 7. Analogue start/stop, 2 10 V / 4 20 mA	oFF					78
501	Digital input pulses	1 - 100	1					79
502	Analogue start-stop on-value	0 - 100 %	25					80
503	Analogue start-stop off-value	0 - 100 %	75					81
504	Analogue start-stop delay time	1 - 999 s	1 s					81
510	Digital input 1 function	oFF. Disabled 1. Start signal 2. Stop signal 3. Parameter set input 1 4. Parameter set input 2 5. External alarm signal 6. Start R signal 7. Start L signal	1					82
511	Digital input 2 function	Same as menu 510	2					82
512	Digital input 3 function	Same as menu 510	3					83
513	Digital input 4 function	Same as menu 510	4					83
Output signals								
520	Analogue output	oFF. Disabled 1. 0 - 10 V / 0 - 20 mA, 2. 2 - 10 V / 4 - 20 mA, 3. 10 - 0 V / 20 - 0 mA, 4. 10 - 2 V / 20 - 4 mA	oFF					83
521	Analogue output function	1 = RMS current 2 = Line voltage 3 = Shaft power 4 = Torque	1					84
522	Scaling analogue output, min	0 - 500 %	0					84

Table 27 Parameter list

Menu no.	Function / Parameter	Range /Settings	Factory setting	Customer setting / Parameter set 1-4				Page
				1	2	3	4	
523	Scaling analogue output, max	0 - 500 %	100					85
530	Relay K1	oFF. Relay inactive 1. Operation 2. Full voltage 3. Power pre-alarms 4. Reverse current brake 5. Run 6. Run R 7. Run L 8. Operation R 9. Operation L 10. Power alarms 11. Max power alarm 12. Max power pre-alarm 13. Min power alarm 14. Min power pre-alarm 15. All alarms (except power pre-alarms) 16. All alarms (except power alarm and pre-alarms) 17. External alarm signal 18. Auto reset expired 19. All alarms which need manual reset	1					86
531	Relay K2	Same as menu 530	2					86
532	Relay K3	Same as menu 530	15					86
533	K1 contact function	1. Normally open (N.O.) 2. Normally closed (N.C.)	1					87
534	K2 contact function	Same as menu 533	1					87
VIEW OPERATION								
Operation								
700	Current	0.0 - 9999 A	Read-out					93
701	Line main voltage	0 - 720 V	Read-out					93
702	Power factor	0.00 - 1.00	Read-out					93
703	Output shaft power	-999 - 9999 kW	Read-out					93
704	Output shaft power in percentage units	0 - 200 % of P _n	Read-out					94
705	Shaft torque	-999 - 9999 Nm	Read-out					94
706	Shaft torque in percentage units	0 - 250 % of T _n	Read-out					94
707	Softstarter temperature	low, 30 - 96 °C resp low, 85 - 204 °F	Read-out					94
708	Current phase L1	0.0 - 9999 A	Read-out					94
709	Current phase L2	0.0 - 9999 A	Read-out					94
710	Current phase L3	0.0 - 9999 A	Read-out					94
711	Line main voltage L1-L2	0 - 720 V	Read-out					94
712	Line main voltage L1-L3	0 - 720 V	Read-out					95
713	Line main voltage L2-L3	0 - 720 V	Read-out					95
714	Phase sequence	L123, L321, L--	Read-out					95

Table 27 Parameter list

Menu no.	Function / Parameter	Range /Settings	Factory setting	Customer setting / Parameter set 1-4				Page
				1	2	3	4	
715	Used thermal capacity	0 - 150 %	Read-out					95
716	Time to next allowed start	0 - 60 min	Read-out					95
Status								
720	Softstarter status	1 - Stopped, no alarm 2 - Stopped, alarm 3 - Run with alarm 4 - Acceleration 5 - Full voltage 6 - Deceleration 7 - Bypassed 8 - PFC 9 - Braking 10 - Slow speed forward 11 - Slow speed reverse 12 - Standby (waiting for analogue start/stop or Auto reset)	Read-out					95
721	Digital input status	LLLL - HHHH	Read-out					95
722	Analogue / digital input status	L, H	Read-out					95
723	Analogue / digital input value	0 - 100 %	Read-out					96
724	Relay status	LLL - HHH	Read-out					96
725	Analogue output value	0 - 100 %	Read-out					96
Stored values								
730	Operation time	0 - 9 999 999 h	Read-out					96
731	Power consumption	0.000 - 2000 MWh	Read-out					96
732	Reset power consumption	no, YES	no					96
ALARM LIST								
800	Alarm list, latest error	F1 - F17, h	Read-out					97
801	Alarm list, error 14	F1 - F17, h	Read-out					97
802	Alarm list, error 13	F1 - F17, h	Read-out					97
803	Alarm list, error 12	F1 - F17, h	Read-out					97
804	Alarm list, error 11	F1 - F17, h	Read-out					97
805	Alarm list, error 10	F1 - F17, h	Read-out					97
806	Alarm list, error 9	F1 - F17, h	Read-out					97
807	Alarm list, error 8	F1 - F17, h	Read-out					97
808	Alarm list, error 7	F1 - F17, h	Read-out					97
809	Alarm list, error 6	F1 - F17, h	Read-out					97
810	Alarm list, error 5	F1 - F17, h	Read-out					97
811	Alarm list, error 4	F1 - F17, h	Read-out					97
812	Alarm list, error 3	F1 - F17, h	Read-out					97
813	Alarm list, error 2	F1 - F17, h	Read-out					97
814	Alarm list, error 1	F1 - F17, h	Read-out					97

Table 27 Parameter list

Menu no.	Function / Parameter	Range /Settings	Factory setting	Customer setting / Parameter set 1-4				Page
				1	2	3	4	
SOFTSTARTER DATA								
900	Softstarter model	17 - 1400 A	Read-out					97
901	Software variant text	Same as label	Read-out					97
902	Software version text	Same as label	Read-out					97
Read-out = Menus only for reading the value/settings.								

Explanation of units:

- U Input line voltage
- U_n Nominal motor voltage.
- I_n Nominal motor current.
- P_n Nominal motor power.
- N_n Nominal motor speed.
- T_n Nominal shaft torque.
- I_{nsoft} Nominal current softstarter.
- P_{nsoft} Nominal power softstarter.
- N_{nsoft} Nominal speed softstarter.

Calculation shaft torque

$$T_n = \frac{P_n}{\left(\frac{N_n}{60} \times 2\pi\right)}$$

Index

Numerics

- 2-wire start/stop with automatic reset at start 87
- 2-wire start/stop with separate reset .. 88
- 3-wire start/stop with automatic reset at start 88

A

- Abbreviations 7
- Actual parameter set 52
- Aggressive environment conditions .. 37
- Alarm braking 64
- Alarm braking strength 64
- Alarm braking time 64
- Alarm codes 99
- Alarm list 97
- Alarm overview 100
- All alarms (except power alarms and pre-alarms) 86
- All alarms (except power pre-alarms) 86
- All alarms which need manual reset .. 86
- Ambient temperature below 0×C 36
- Analogue input 80
- Analogue output 83
- Analogue Output value 96
- Analogue start/stop 80
 - 0-10 V / 0-20 mA Or 2-10 V / 4-20 mA 78
- Analogue/digital input 78
- Analogue/digital Input status 95
- Analogue/digital input value 96
- Applications and functions selection 31
- Auto reset 52
- Auto reset expired 86
- Auto set 74, 78
- Automatic return menu 44

B

- Background theory 9
- Bandsaw 35
- Blower 34
- Brake 86, 99
- Braking 62
- Braking method 64
- Braking strength 64
- Busbar distances 16
- Bypass 68

C

- Cable kit for external current transformers 110
- CAUTION 5
- Centrifuge 35
- Checklist 27
- Coast 99
- Compressor 34

- Connections 19
- Control Connection 24
- Control panel 39, 42
- Control panel lock 41, 44
- Control source 44
- Control sources 42
- Conveyor 35
- Cooling 15
- Copy parameter set 52
- Current 44
- Current limit 59
- Current limit at start 59
- Current limit start time expired 51
- Current transformer 69

D

- DC brake at slow speed 67
- Definitions 7
- Derating at higher temperature 122
- Description 9
- Digital input 79
- Digital input pulses 79
- Digital Input Status 95
- Digital inputs 81
- Direct on-line, DOL 59
- Dynamic vector brake 62

E

- Earth fault relay 37
- Electrical specifications 113
- Enable US units 45
- End torque at start 58
- End torque at stop 61
- Energy consumption 96
- Environmental conditions 122
- External alarm 74, 86
- External alarm functionality 92
- External alarm signal 82, 83
- External control of parameter set 92
- External control panel 109

F

- Fan 35
- Fan continuously on 70
- Fieldbus systems 109
- Full voltage 86
- Functional description 43
- Fuses and power losses 119

G

- General electrical specifications 118
- Glossary 7

H

- Hammer mill 36
- Hole pattern 17

- How to get started 27
- How to use the Instruction Manual ... 5

I

- I/O settings 78
- Initial torque at start 58
- Initial voltage at start 59
- Input signals 78
- Installation of the softstarter in a cabinet 15
- Insulation test on motor 37
- Integrated safety systems 5
- Internal protection class 47
- IT earthing system 37
- IT-net option 111

J

- Jog Forward 78
- JOG forward enable 68
- Jog reverse 78
- JOG reverse enable 68

K

- Keys 40

L

- LED indication 40
- Line main voltage 93
- Load monitor 70
- Locked rotor 49

M

- Mains protection 75
- Max power alarm 72, 86
- Max power pre-alarm 86
- Menu structure 40
- Min power alarm 72, 86
- Min power pre-alarm 86
- Min. time between starts 49
- Minimum wiring 25
- Mixer 36
- Motor data 45
- Motor protection 46
- Mounting 15
- Mounting schemes 16

N

- Normal load 74
- NOTE 5, 6, 19
- Notes to the Instruction Manual 5
- Number of starts per hour 49

O

- Operation 86
- Operation above 1000 m 37
- Operation L 86

Operation R	86	Slow speed controlled by an external signal	65, 66	V	View operation	93
Options	109	Slow speed for a selected time	66	Voltage control	58, 61	
Output shaftpower	93	Slow speed strength	67	Voltage unbalance alarm	75	
Output signals	83	Slow speed time at start	67	W		
Overvoltage alarm	76	Slow speed time at stop	67	WARNING	5	
P		Slow speed using the JOG commands	65, 67	Warning	99	
Parameter set handling	51	Small motor or low load	36	Wiring examples	25	
Parameter set, input 1	82, 83	Softstarter data	97			
Parameter set, input 2	82, 83	Softstarter rating	31			
PCB Terminals	24, 123	Softstarter status	95			
Phase compensation capacitor	36	Softstarter temperature	94			
Phase input failure	50	Special conditions	36			
Phase reversal alarm	77	Spinbrake	99			
Phase sequence	95	Standards	122			
Planer	35	Start	57			
Power alarms	86	Start delay power alarms	72			
Power- and signal connectors	123	Start L signal	82, 83			
Power factor	93	Start limitation	48			
Power Factor Control PFC	70	Start method	57			
Power pre-alarms	86	Start R signal	82, 83			
Preset pump control	56	Start right/left functionality	88			
Process protection	70	Start signal	82, 83			
Programmable relay outputs	85	Start time	60			
Protection and alarm	99	Start/stop/reset command functionality	87			
PTC input	47	Starting with counter-clockwise rotating loads	36			
Pump	34	Step down voltage at stop	61			
R		Step-up transformer for high voltage motor	37			
Reduced voltage starting	10	Stop	60, 99			
Relay status	96	Stop method	61			
Remote	42	Stop signal	82, 83			
Reset	99	Stop time	64			
Reset energy consumption	96	Stored values	96			
Reset to factory setting	52	T				
Reverse current brake	62	Technical data	113			
RMS current	93	Terminal clamp	110, 111			
Rock crusher	35	The Application Functions List	34			
Rotation sensor	78	Thermal motor protection	46			
Run	86	Time to next allowed start	49			
Run L	86	Torque boost	60			
Run R	86	Torque boost active time	60			
Running motors connected in parallel	36	Torque boost current limit	60			
Running motors linked together	37	Torque control	58, 61			
S		Torque control at start	58			
Safety	1	Torque control at stop	61			
Safety instructions	1	Troubleshooting	103			
Safety measures	5	Type number	6			
Scaling of analogue output	84	U				
Select parameter set	51	Undervoltage alarm	76			
Semi-conductor fuses	124	Upper mounting bracket	17			
Serial communication	42, 55, 109	Used thermal capacity	47, 95			
Set-up menu list	125					
Shaft torque	94					
Shielded control cable	19					
Shielded motor cable	36					
Single phase input failure	50					
Slow speed	78					

CG Drives & Automation Sweden AB

Mörsaregatan 12

Box 222 25

SE-250 24 Helsingborg

Sweden

T +46 42 16 99 00

F +46 42 16 99 49

www.emotron.com / www.cgglobal.com